

# Fans and drive concepts for rail technology

Product Catalogue 2018-09

**ebmpapst**

the engineer's choice

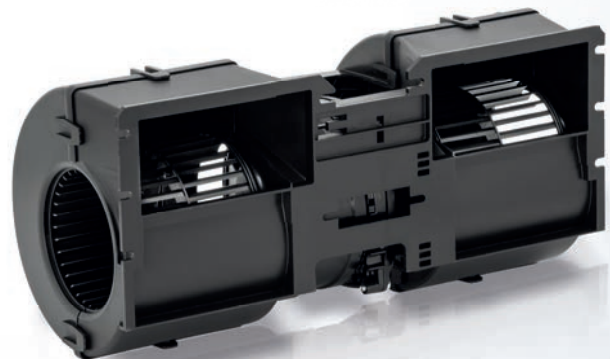



## Fans and drive concepts for rail technology

Those who have to guarantee maximum reliability every day and want to offer optimum comfort need technologies they can rely on.

To this end, we develop ventilation and drive technology that sets standards - even under consideration of the strictest requirements.





# Fans and drive concepts for rail technology

**ebmpapst**

the engineer's choice



	Page		Page
<b>Information</b>	<b>4</b>	About ebm-papst	4
		ebm-papst: Your highly competent partner in rail engineering	6
		Fire safety in rail vehicles	7
		Product overview	8
		<b>Fans and drive concepts for rail technology</b>	<b>14</b>
		EC / DC centrifugal fans backward-curved Ø 190 - Ø 400	20
		EC / DC axial fans Ø 300 - Ø 500	72
		DC compact fans axial fan Ø 172 x 51, centrifugal fan □ 127 x 25	94
		AC centrifugal fans backward-curved Ø 190 - Ø 280	104
		AC centrifugal fans vorward-curved Ø 120 - Ø 250 (with housing, single-intake)	122
		AC centrifugal fans vorward-curved Ø 133 - Ø 200 (with housing, dual-intake)	154
		Drive concepts: door drives, drives for entry aids, special applications	178
<b>Accessories</b>	<b>182</b>	FlowGrid air inlet grill	184
		Mounting dimensions for centrifugal modules	185
		Inlet rings for centrifugal fans	186
<b>Technology</b>	<b>190</b>	Connection diagrams	192
		Technical parameters & scope	204
<b>ebm-papst agents</b>	<b>210</b>		210

Information

Fans and drive concepts for rail technology

Accessories

Technology

Agents

# About ebm-papst

*As technological leader for ventilation and drive engineering, ebm-papst is in demand as an engineering partner in many industries. With over 15,000 different products, we provide the right solution for just about any challenge. Our fans and drives are reliable, quiet and energy-efficient.*

Six reasons that make us the ideal partner:

#### **Our systems expertise.**

You want the best solution for every project. The interrelationships between ventilation and drive engineering must thus be considered as a whole.

And that's what we do – with motor technology that sets standards, sophisticated electronics and aerodynamic designs – all from a single source and perfectly matched. These system solutions release unique synergies worldwide. And in particular – they relieve you of a lot of work, so that you can concentrate on your core competency.

#### **The ebm-papst spirit of invention.**

In addition to our wide range of products, we are always able to develop customized solutions for you. A diversified team of 600 engineers and technicians works at our three locations in Germany: Muldingen, Landshut and St. Georgen. Contact us to discuss your next project.

#### **Our lead in technology.**

As pioneer and trail-blazer for developing highly efficient EC technology, we are way ahead of other motor manufacturers. Almost all our products are also available with GreenTech EC technology. The list of benefits is long: higher efficiency, maintenance-free, longer service life, sound reduction, intelligent control characteristics and unrivalled energy efficiency with savings of up to 80 % compared to conventional AC technology. Let our technology be your competitive advantage as you lead in your industry.

#### **Closeness to our customers.**

ebm-papst has 25 production locations worldwide (including facilities in Germany, China and the USA), together with 49 sales offices, each of which has a dense network of sales representatives. You will always have a local contact, someone who speaks your language and knows your market.

#### **Our standard of quality.**

Of course you can rely on the highest standards of quality with our products. Our quality management is uncompromising, at every step in every process. This is underscored by our certification according to international standards including DIN EN ISO 9001, TS declaration of conformity and DIN EN ISO 14001.

#### **Our sustainable approach.**

Assuming responsibility for the environment, for our employees and for society is an integral part of our corporate philosophy. We develop products with an eye to maximum environmental compatibility, in particular resource-preserving production methods. We promote environmental awareness among our young staff and are actively involved in sports, culture and education. That's what makes us a leading company – and an ideal partner for you.



# The story of our success to *market and technology pioneer.*

- 1963 Founding of **Elektrobau Mulfingen GmbH & Co. KG** by Gerhard Sturm and Heinz Ziehl.
- 1965 First tubeaxial fan developed in EC/DC technology.
- 1966 ebm's success takes off with the new 68 motor.
- 1972 The first ebm foreign subsidiary is established in Sweden.
- 1988 Gerhard Sturm is awarded the Federal Cross of Merit.
- 1990 The sixty-millionth external-rotor fan is produced.
- 1992 Acquisition of **PAPST Motoren GmbH** in St. Georgen.
- 1997 Buyout of the **Landshut (mvl)** plant.
- 1998 Development of first fans with integrated electronics.
- 2003 Change of name to **ebm-papst**.
- 2008 The **HyBlade®** range of fans sets new efficiency standards.
- 2010 **GreenTech** – our sign for energy efficiency and resource preservation.
- 2011 **RadiCal** defines a new standard for EC centrifugal fans.
- 2013 ebm-papst takes over the gearbox specialist Zeitlauf and wins the **German Sustainability Award**.
- 2014 Team partnership with Mercedes AMG PETRONAS Formula 1 team.
- 2015 **RadiPac** pushes the limits of efficiency.
- 2016 **AxiBlade** sets new standards in ventilation, refrigeration and air-conditioning.



# ebm-papst: Your highly competent partner in *rail engineering*

## Creating the ideal fan solution.

The area of railways places particular requirements on a product. Fans developed uniquely for rail technology and for the specific field of application will help to achieve a high level of customer satisfaction in the long-term. Introducing standard products in rail vehicles is frivolous and sooner or later becomes expensive for the customer. To find the best solution for the individual rail use in each case, a comparison of the requirements in the field and the performance features of the fan is necessary.

• **EN 50155: 2007/2017 Railway applications. Electronic equipment used on rolling stock / rail technology fans by ebm-papst are compliant with EN 50155.**

- **IEC 61373: 2010 Shock and vibration tests**

The fans are tested according to category 1B. The entire system must be tested separately.

- **EN 60721-3-5: 1998 Environmental conditions**

Climatic environmental conditions: 5K2

Chemically active substances: 5C1

Mechanically active substances: 5S1

Biological environmental conditions: 5B1

Contamination agents: 5F1

Mechanical environmental conditions: 5M1

**Environmental conditions tested according to EN 50155 Section 13.3, table 12**

- **EN 50121-3-2: 2016 Electromagnetic compatibility**

- **EN 50124-1: 2017 Insulation coordination**

Note on routine testing of customer units with 24 VDC fans:  
Before insulation testing, all fan connections must be disconnected from the customer unit.

• **EN 15085-1/3: 2013 Welding of railway vehicles and components / weld seam quality CPC3**

• **EN 45545-2+A1: 2015 Fire protection on railway vehicles**  
The fans fulfil the requirements according to HL3. The fire protection requirements of the entire system must be assessed separately.

• **EN 50533/A1: 2016 Properties of 3-phase electrical system voltage / Class 1 electrical system architecture is a prerequisite for using EC fans.**

## Our advantage lies in the perfect interaction.

Significantly increased passenger and cargo demands due to advancing globalization require new solutions, particularly in rail traffic. Powerful and reliable vehicle concepts provide the basis for vehicles for transport solutions that are more efficient and, above all, more environmentally friendly. An essential part of this effort is cooling both diesel-powered and electrically powered rail cars as well as providing maximum comfort for passenger transportation. Precisely in this area, ebm-papst has time and again set new standards with brushless fans.

## Leading technologies, groundbreaking application solutions, innovative products – all of these would not be possible if we did not see the big picture:

Aerodynamic optimization and therefore the perfect combination of motor technology, electronics and aerodynamics. Our three core competencies are in direct relationship to each other in our products. The objective is always to use air and motion as efficiently as possible, whether in the tightest spaces, in large dimensions or under extreme ambient conditions. We believe that this cohesive strategy is the only way to give our customers high quality and perfectly optimized end products. Whether they are high-performance driver's cab climate control systems and heating units, versatile passenger compartment systems or effective cooling of power electronics in locomotives.

In order to achieve an aerodynamically optimum shape for our fans, we design fan blades, impellers and ducted housings to match the relevant application environment. From seemingly small details, such as the bladetip slip with winglets, result significant optimizations for noise reduction with even higher efficiencies. And when they are combined with intelligent electronics, the drive engineering and aerodynamics then operate as a system solution optimally matched to each other. The perfect combination thus arises: our lead in global competition.

**If the conditions under application exceed the tested requirements, then please arrange a consultation with ebm-papst.**



# Fire safety in *rail vehicles*

The European standard EN 45545 for fire safety in rail vehicles was ratified in 2013, and the transitional period for national sets of rules expired at the end of March 2016.

The seven-part standard has the objective of protecting passengers and staff in case of fire on board and assuring evacuation. Part 2 of the standard describes the requirements for the degree of flammability of materials and components.

The level of severity of the limit values to be adhered to depends on the hazard level. There are three hazard levels (HL). HL1 is the lowest level and HL3 designates the strictest limit values.

The operating and construction classes of the respective components determine the component's hazard level.

With its series for railway applications, ebm-papst offers fans that are precisely tailored to comply with the fire safety criteria.

Compliance with the requirements of the standards is proven with material tests and extensive product assessment, as well as with independent appraisals.

The findings confirm that the design and material selection completely satisfy the requirements of DIN EN 45545-2 and meet the requirements for HL3.

Concretely, this means that all the relevant components possess the test certificates they require and that they are all currently valid.

Specific properties of the products' construction were also verified.

ebm-papst subjected the products to voluntary testing and certification by TÜV SÜD.

The test certificates granted confirm that the ebm-papst fans presented in this catalog an intended for railway applications meet all the relevant safety requirements and possess the relevant product properties required.

The certification also includes regular production facilities monitoring.





**The fire safety substantiation confirms the fans' unlimited suitability for use in rail vehicles.**

# Product overview – Fans and drive concepts for rail technology

## EC / DC dual centrifugal fans (forward curved with housing)

Ø	Nominal voltage	Air performance	Dual centrifugal fan forward curved with housing 	on Page
097	24 V DC	1310	K3G097AS8181	16
	24 V DC	1580	K3G097AS8282	
	110 V DC	1180	K3G097AT85P1	

## EC / DC centrifugal fans (backward curved)



Ø	Nominal voltage	Air performance	Centrifugal fan backward curved 	With support structure 	on Page
190	24 V DC	750	R1G190RD7981	---	22
	110 V DC	930	R3G190RY85P1	---	
220	24 V DC	1080	R1G220RD1081	---	26
	110 V DC	1280	R3G220RY90P1	---	
250	24 V DC	1260	R1G250RC8781	---	30
	24 V DC	2100	R3G250RU2781	K3G250RU2781	
	110 V DC	1600	R3G250RY90P1	---	
	110 V DC	2050	R3G250RR09P1	K3G250RR09P1	
	400 V AC	2120	R3G250RR04N1	K3G250RR04N1	
250 (Alu)	110 V DC	3150	R3G250BB09S1	K3G250BB09S1	38
	400 V AC	3500	R3G250BB01N1	K3G250BB01N1	
280	24 V DC	2000	R1G280RC7181	---	42
	24 V DC	2750	R3G280RU2681	K3G280RU2681	
	24 V DC	3300	R3G280RU6582	K3G280RU6582	
	110 V DC	3280	R3G280RR10P1	K3G280RR10P1	
	400 V AC	3320	R3G280RR05N1	K3G280RR05N1	
280 (Alu)	110 V DC	3480	R3G280BD13S1	K3G280BD13S1	50
	400 V AC	3800	R3G280BC01N1	K3G280BC01N1	
310	24 V DC	3750	R3G310RU2981	K3G310RU2981	54
	110 V DC	3500	R3G310RR12P1	K3G310RR12P1	
	400 V AC	3800	R3G310RR05N1	K3G310RR05N1	
310 (Alu)	110 V DC	4950	R3G310BE84S1	K3G310BE84S1	60
	400 V AC	5200	R3G310BE90N1	K3G310BE90N1	
355	110 V DC	4600	R3G355RS13P1	---	64
	110 V DC	5500	R3G355RJ85S1	---	
	400 V AC	5550	R3G355RJ76N1	---	
400 (Alu)	400 V AC	9200	R3G400BE08N1	---	68





## EC / DC axial fans

Ø	Nominal voltage	Air performance	Axial fan 	on Page
300 / 385	24 V DC	2650	W3G300BV2582	74
	24 V DC	4100	W3G385CT6581	
300 / 350	110 V DC	3100	W3G300CT80P1	78
	110 V DC	3350	W3G350CT81P1	

## EC / DC axial fans

Ø	Nominal voltage	Air performance	Axial fan 	With round full nozzle 	on Page
400	110 V DC	5850	A3G400BK13P3	W3G400CK13P3	82
450	110 V DC	7550	A3G450BL17P3	W3G450CL17P3	86
	400 V AC	7250	A3G450BL12N1	W3G450CL12N1	
500	110 V DC	10500	A3G500BA73S1	W3G500CA73S1	90
	400 V AC	10500	A3G500BA74N1	W3G500CA74N1	

## DC compact fans

	Nominal voltage	Air performance	Axial fan 	Radial fan 	on Page
6300 NTD	24 V DC	820	6314N2TDHOU-305	---	96
RLF 100	24 V DC	65	---	RLF100-11/14PU-217	100

Subject to technical changes.

# Product overview – Fans and drive concepts for rail technology

AC centrifugal fans ( <i>backward curved</i> )				
Ø	Nominal voltage	Air performance	Centrifugal fan backward curved 	on Page
190	400 V AC / Y / 50 Hz	550	R2D190RB1811	106
	400 V AC / Y / 60 Hz	600		
220	400 V AC / Δ / 50 Hz	1000	R2D220RC3611	110
	400 V AC / Y / 50 Hz	900		
	480 V AC / Δ / 60 Hz	1200		
	480 V AC / Y / 60 Hz	1000		
250	400 V AC / Δ / 50 Hz	1400	R2D250RC1011	114
	400 V AC / Y / 50 Hz	1180		
	480 V AC / Δ / 60 Hz	1680		
	480 V AC / Y / 60 Hz	1380		
280	400 V AC / Δ / 50 Hz	3000	R2D280RB0811	118
	400 V AC / Y / 50 Hz	2250		

Subject to technical changes.



AC centrifugal fans (*vorward curved with housing*)

Ø	Nominal voltage	Air performance	Centrifugal fan vorward curved with housing single-intake 	on Page
120	400 V AC / Y / 50 Hz	290	G2D120AA2203	124
	480 V AC / Y / 60 Hz	250		
140	400 V AC / Δ / 50 Hz	460	G2D140AC3803	128
	400 V AC / Y / 50 Hz	320		
	480 V AC / Δ / 60 Hz	530		
	480 V AC / Y / 60 Hz	350		
160	400 V AC / Δ / 50 Hz	670	G2D160AF1203	132
	400 V AC / Y / 50 Hz	410		
	400 V AC / Δ / 60 Hz	500		
	400 V AC / Y / 60 Hz	310		
180	400 V AC / Δ / 50 Hz	460	G2D180AB1003	136
	400 V AC / Y / 50 Hz	320		
	480 V AC / Δ / 60 Hz	530		
	480 V AC / Y / 60 Hz	350		
180	400 V AC / Δ / 50 Hz	1010	G4D180FF2402	140
	400 V AC / Y / 50 Hz	750		
	480 V AC / Δ / 60 Hz	1180		
	480 V AC / Y / 60 Hz	800		
200	400 V AC / Δ / 50 Hz	1400	G4D200BL1903	144
	400 V AC / Y / 50 Hz	1000		
	480 V AC / Δ / 60 Hz	1180		
	480 V AC / Y / 60 Hz	880		
225	400 V AC / Δ / 50 Hz	1600	G4D225FK2002	148
	400 V AC / Y / 50 Hz	1220		
	480 V AC / Δ / 60 Hz	1700		
	480 V AC / Y / 60 Hz	1280		
250	400 V AC / Δ / 50 Hz	1980	G4D250DC1402	152
	400 V AC / Y / 50 Hz	1580		
	480 V AC / Δ / 60 Hz	2000		
	480 V AC / Y / 60 Hz	1560		

# Product overview – Fans and drive concepts for rail technology

AC centrifugal fans ( <i>vorward curved with housing</i> )					
Ø	Nominal voltage	Air performance	Cntrifugal fan vorward curved with housing dual-intake		on Page
133	400 V AC / Δ / 50 Hz	740	D2D133DB4003		158
	400 V AC / Y / 50 Hz	480			
	400 V AC / Δ / 60 Hz	690			
	400 V AC / Y / 60 Hz	420			
146	400 V AC / Δ / 50 Hz	800	D2D146AA1203		162
	400 V AC / Y / 50 Hz	520			
	400 V AC / Δ / 60 Hz	640			
	400 V AC / Y / 60 Hz	380			
160	400 V AC / Y / 50 Hz	1520	D2D160BE0203		166
	400 V AC / Y / 60 Hz	1700			
180	400 V AC / Y / 50 Hz	1780	D4D180BB0903		170
	480 V AC / Y / 60 Hz	1760			
200	400 V AC / Y / 50 Hz	2480	D4D200BA0103		174
	480 V AC / Y / 60 Hz	2300			

Subject to technical changes.





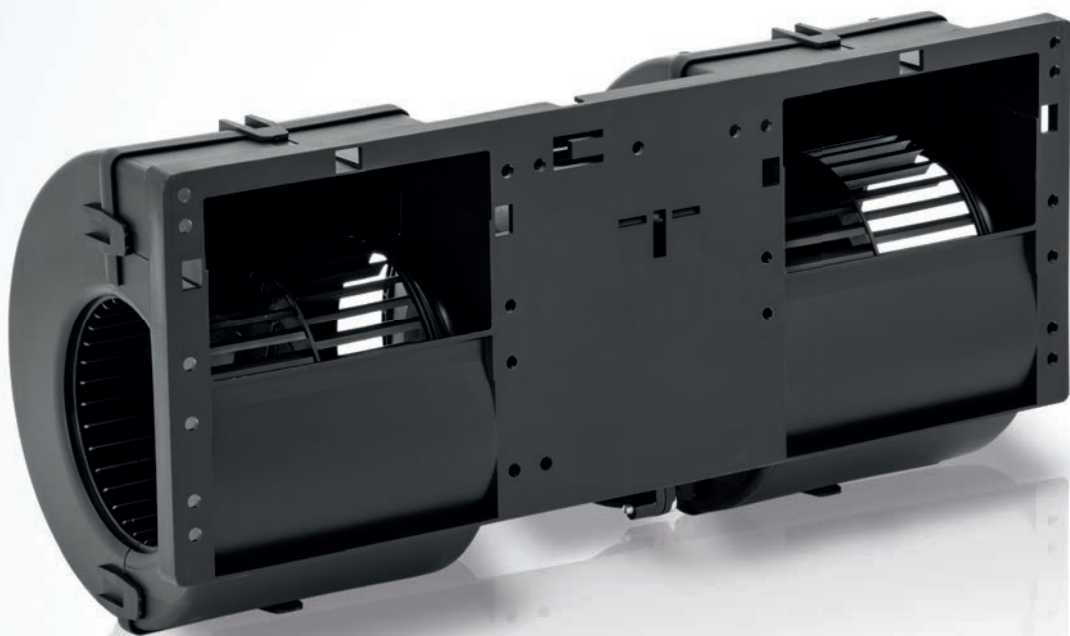

# EC / DC dual centrifugal fans *forward curved with housing* Ø 097

**ebmpapst**

the engineer's choice

	Page
Ø 097	16



# EC / DC dual centrifugal fans

forward curved with housing, Ø 097 mm



### Material/surface

- Scroll housing: PA66 plastic, black
- Impeller: PA66 plastic, black

### Mechanical data

- Mode: Continuous operation (S1)
- Mounting: Maintenance-free ball bearings
- Cable exit: lateral

### Standards and approvals

- Conformity with standards: see page 6
- Approvals: EAC

on Page 18	Drawings
on Page 192	Connection diagrams and technical features
on Page 204	Technical parameters & scope
More at	<a href="http://www.ebmpapst.com">www.ebmpapst.com</a>

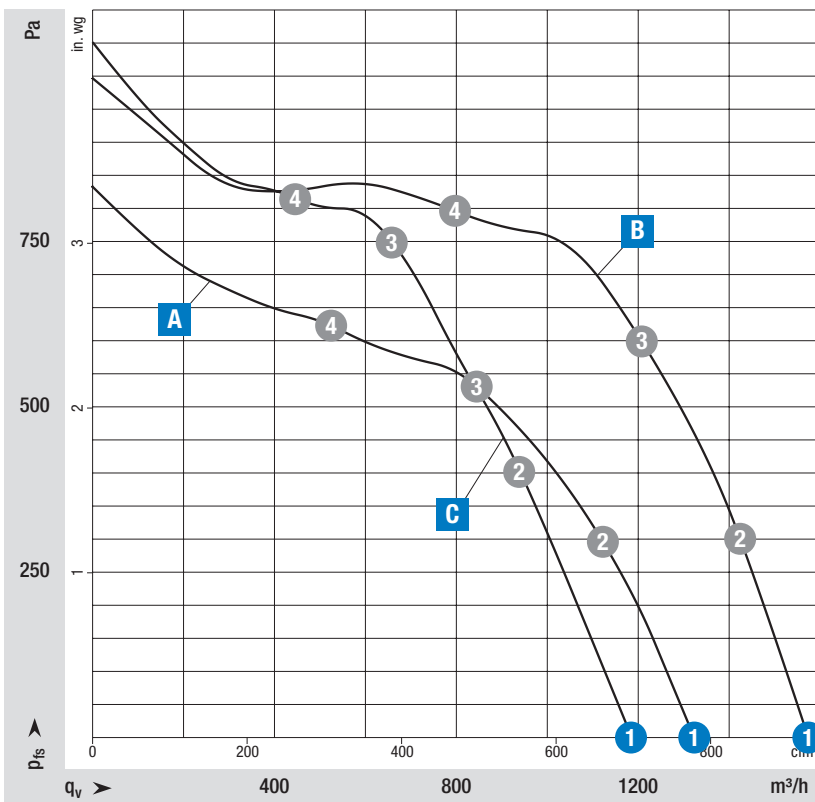

**Measuring requirements**  
 Air performance measured according to: ISO 5801, installation category A, with ebm-papst scroll housing without contact protection.  
 Intake-side sound level:  $L_{pA}$  according to ISO 13347,  $L_{pA}$  measured at 1 m distance from fan axis. The values given are only applicable under the specified measuring conditions and may differ depending on the installation conditions. In the event of deviation from the standard configuration, the parameters must be checked in installed condition.

Curve	Operating point	Nominal voltage	Speed n	Max. Input power $P_{ed}$	Max. Input current I	Sound power level $L_{wA}$	Protection class	Installation position	Perm. ambient temp.	Degree of protection	Insulation class	Conn. diagram
		VDC	rpm	W	A	dB(A)			°C			
Voltage range 16-32 V DC												
<b>A</b>	1	24	3900	435	16,6	84	I	Any	-40...+70	Motor: IP 24 KM Electr.: IP 66/69 K	B	BA3)
	2	24	4375	412	15,8	82						
	3	24	4620	324	12,5	80						
	4	24	4820	233	9,0	79						
<b>B</b>	1	24	4680	740	28,0	88	I	Any	-40...+70	Motor: IP 24 KM Electr.: IP 66/69 K	B	BA2)
	2	24	5025	740	28,0	87						
	3	24	5380	659	25,3	85						
	4	24	5500	441	16,9	84						
Voltage range 77-138 V DC												
<b>C</b>	1	110	3450	330	3,0	81	III	Any	-40...+60	IP 6K9K	B	BA5)
	2	110	4375	330	3,0	80						
	3	110	5350	330	3,0	82						
	4	110	5495	253	2,3	82						

Values set in blue are nominal data at operating point with maximum load.

Subject to change



Curve	Dual centrifugal fan	
	Part number	Weight
		kg
<b>A</b>	K3G097AS8181	2,00
<b>B</b>	K3G097AS8282	2,00
<b>C</b>	K3G097AT85P1	2,65

**A** K3G097AS8181 (Dual centrifugal fan)

Dimensions in mm

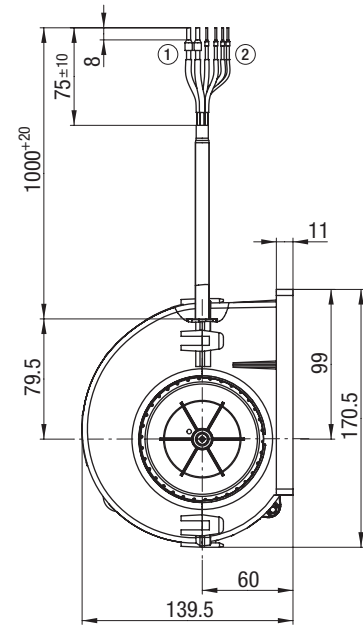
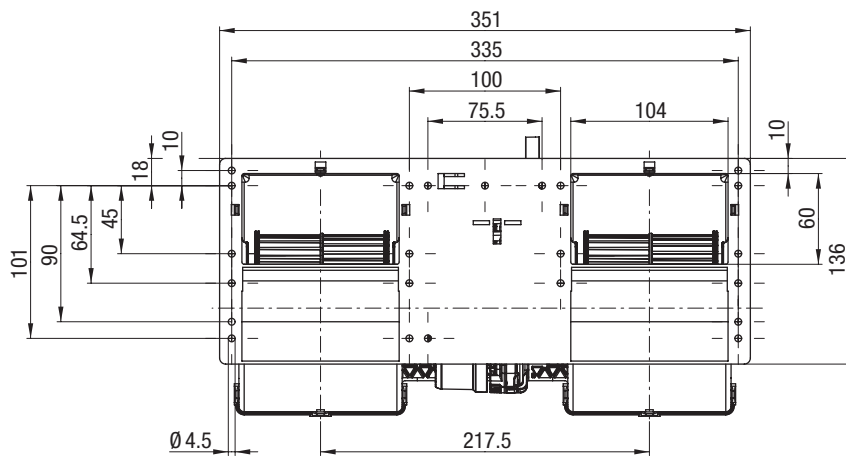

Cable (halogen-free):

- ① BETAtrans® GKW R 2.5 mm<sup>2</sup>, 2x crimped ferrules (brown, black)
- ② BETAtrans® GKW R 1.0 mm<sup>2</sup>, 4x crimped ferrules (yellow, orange, blue, white)

Pin assignment: see connection diagram

**B** K3G097AS8282 (Dual centrifugal fan)

Dimensions in mm

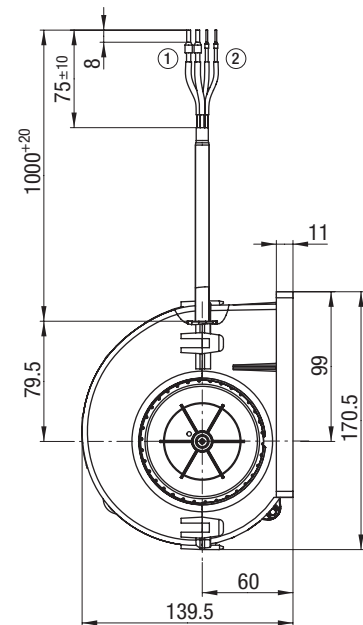
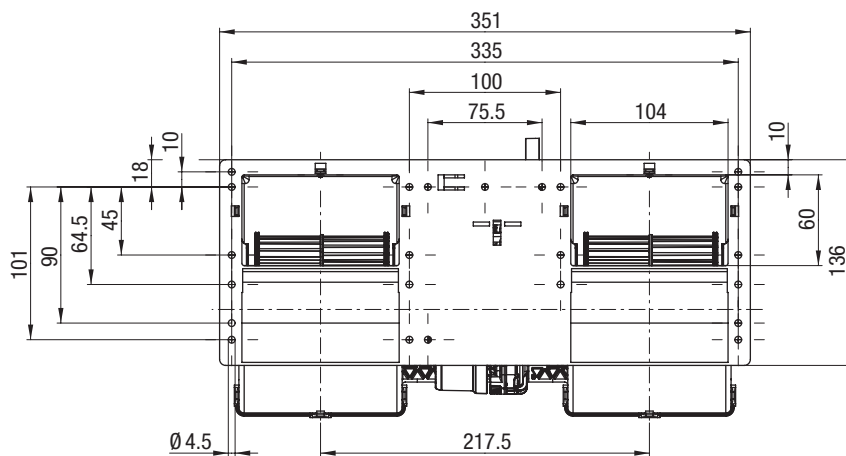

Cable (halogen-free):

- ① BETAtrans® 3 GKW 6.0 mm<sup>2</sup>, 2x crimped ferrules (brown, black)
- ② BETAtrans® 3 GKW 1.0 mm<sup>2</sup>, 2x crimped ferrules (yellow, white)

Pin assignment: see connection diagram

C K3G097AT85P1 (Dual centrifugal fan)

Dimensions in mm

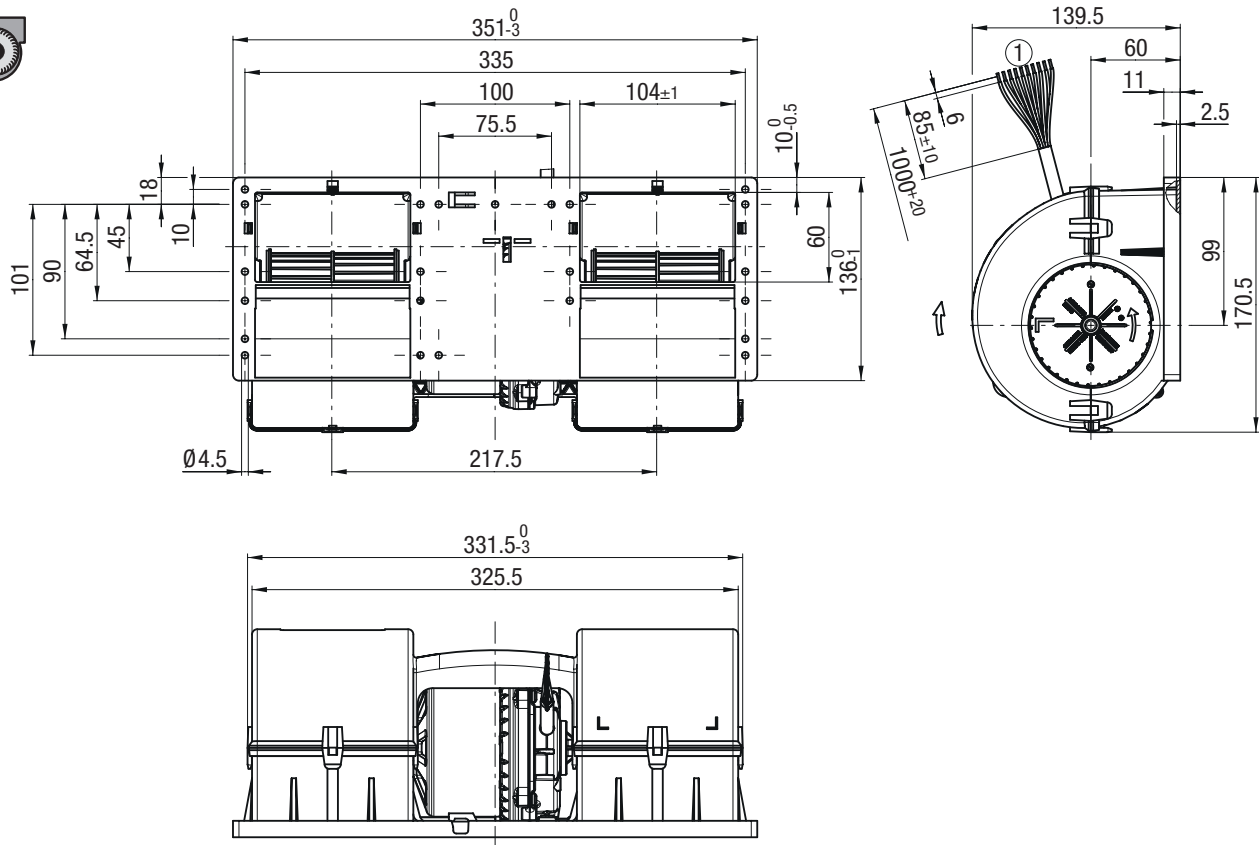

Cable (halogen-free):

- ① BETAtrans® GKW Flex R, 10G 1.0 mm<sup>2</sup>, 10x crimped splices

Pin assignment: see connection diagram





# EC / DC centrifugal fans *backward curved* Ø 190 - Ø 400

**ebmpapst**

the engineer's choice

	Page
Ø 190 RadiCal	22
Ø 220 RadiCal	26
Ø 250 RadiCal	30
Ø 250 Aluminium impeller	38
Ø 280 RadiCal	42
Ø 280 Aluminium impeller	50
Ø 310 RadiCal	54
Ø 310 Aluminium impeller	60
Ø 355 RadiCal	64
Ø 400 Aluminium impeller	68

# EC / DC centrifugal fans

backward curved,  $\varnothing 190\text{ mm}$



### Material/surface

- Impeller: PA66 plastic, black
- Rotor: Painted black/galvanized
- Electronics housing: Die-cast aluminium

### Mechanical data

- Direction of rotation: Clockwise viewed toward rotor
- Mode: Continuous operation (S1)
- Mounting: Maintenance-free ball bearings
- Cable exit: lateral

### Standards and approvals

- Conformity with standards: see page 6
- Approvals: EAC

on Page 24	Drawings
on Page 182	Accessories
on Page 192	Connection diagrams and technical features
on Page 204	Technical parameters & scope
More at	<a href="http://www.ebmpapst.com">www.ebmpapst.com</a>

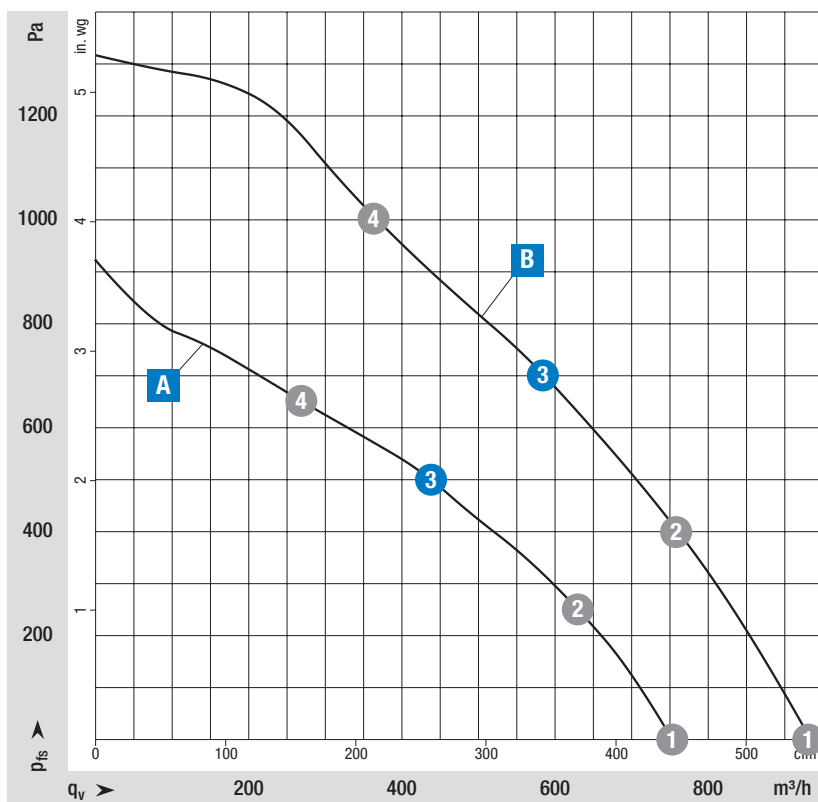

#### Measuring requirements

Air performance measured according to: ISO 5801, installation category A, with ebm-papst inlet ring without contact protection.  
 Intake-side sound level:  $L_{pA}$  according to ISO 13347,  $L_{pA}$  measured at 1 m distance from fan axis. The values given are only applicable under the specified measuring conditions and may differ depending on the installation conditions. In the event of deviation from the standard configuration, the parameters must be checked in installed condition.

Curve	Operating point	Nominal voltage	Speed n	Max. Input power P <sub>ed</sub>	Max. Input current I	Sound power level L <sub>WA</sub>	Protection class	Installation position	Perm. ambient temp.	Degree of protection	Insulation class	Conn. diagram
		VDC	rpm	W	A	dB(A)						
Voltage range 16-32 V DC												
<b>A</b>	1	24	4200	135	5,60	81	III	Shaft horizontal or rotor on bottom	-25...+60	Motor: IP 24 KM Electr.: IP 66/69 K	B	BA1)
	2	24	4080	142	5,90	77						
	3	24	3985	147	6,12	73						
	4	24	4115	140	5,83	75						
Voltage range 77-138 V DC												
<b>B</b>	1	110	5420	270	2,50	88	I	Any	-40...+60	IP 6K9K	B	BA5)
	2	110	5165	270	2,50	84						
	3	110	5000	270	2,50	80						
	4	110	5160	270	2,50	81						

Values set in blue are nominal data at operating point with maximum load.

Subject to change

Curve		
	Centrifugal fan	
	Part number	Weight
		kg
<b>A</b>	R1G190RD7981	1,45
<b>B</b>	R3G190RY85P1	2,00



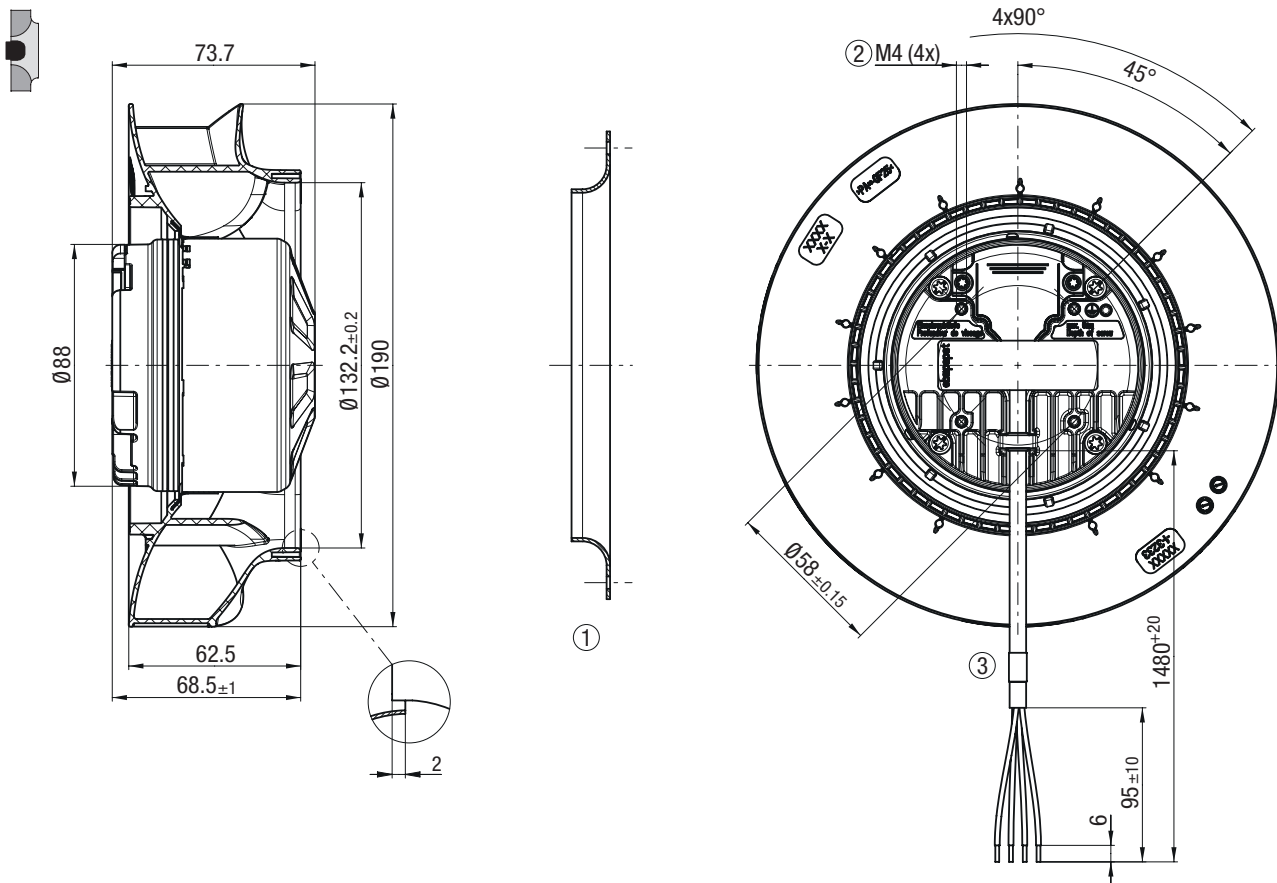

- ① **Accessory part:** Inlet ring 09576-2-4013, not included in scope of delivery  
Dimensions: see "Accessories" chapter
- ② **Max. clearance of screw:** max. 6 mm
- ③ **Cable:** 4x BETAtrans<sup>®</sup> GKW R 0.75 mm<sup>2</sup>, 4x crimped splices

Pin assignment: see connection diagram



# EC / DC centrifugal fans

backward curved,  $\varnothing 220$  mm



### Material/surface

- Impeller: PA66 plastic, black
- Rotor: Painted black/galvanized
- Electronics housing: Die-cast aluminium

### Mechanical data

- Direction of rotation: Clockwise viewed toward rotor
- Mode: Continuous operation (S1)
- Mounting: Maintenance-free ball bearings
- Cable exit: lateral

### Standards and approvals

- Conformity with standards: see page 6
- Approvals: EAC

on Page 28	Drawings
on Page 182	Accessories
on Page 192	Connection diagrams and technical features
on Page 204	Technical parameters & scope
More at	<a href="http://www.ebmpapst.com">www.ebmpapst.com</a>

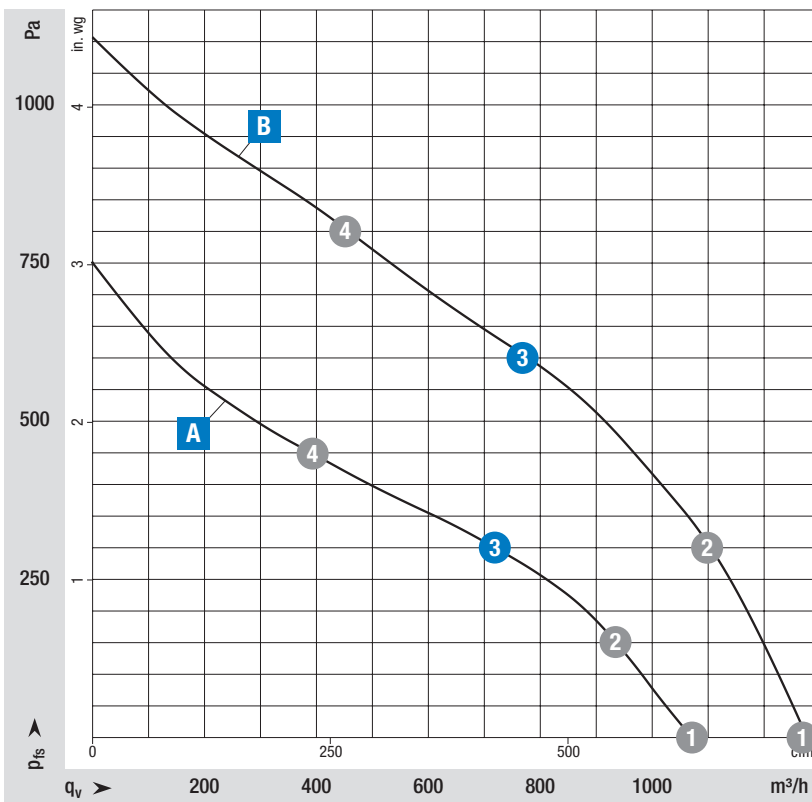

#### Measuring requirements

Air performance measured according to: ISO 5801, installation category A, with ebm-papst inlet ring without contact protection.  
 Intake-side sound level:  $L_{pA}$  according to ISO 13347,  $L_{pA}$  measured at 1 m distance from fan axis. The values given are only applicable under the specified measuring conditions and may differ depending on the installation conditions. In the event of deviation from the standard configuration, the parameters must be checked in installed condition.

Curve	Operating point	Nominal voltage	Speed n	Max. Input power P <sub>ed</sub>	Max. Input current I	Sound power level L <sub>WA</sub>	Protection class	Installation position	Perm. ambient temp.	Degree of protection	Insulation class	Conn. diagram
		VDC	rpm	W	A	dB(A)						
Voltage range 16-32 V DC												
<b>A</b>	1	24	3050	125	5,20	78	III	Shaft horizontal or rotor on bottom	-25...+60	Motor: IP 24 KM Electr.: IP 66/69 K	B	BA1)
	2	24	3085	131	5,43	75						
	3	24	2965	132	5,50	71						
	4	24	3065	130	5,40	72						
Voltage range 77-138 V DC												
<b>B</b>	1	110	4125	265	2,40	87	I	Any	-40...+60	IP 6K9K	B	BA5)
	2	110	4050	265	2,50	83						
	3	110	3850	265	2,50	78						
	4	110	4045	265	2,50	81						

Values set in blue are nominal data at operating point with maximum load.

Subject to change

Curve		
	Centrifugal fan	
	Part number	Weight
		kg
<b>A</b>	R1G220RD1081	1,50
<b>B</b>	R3G220RY90P1	2,10

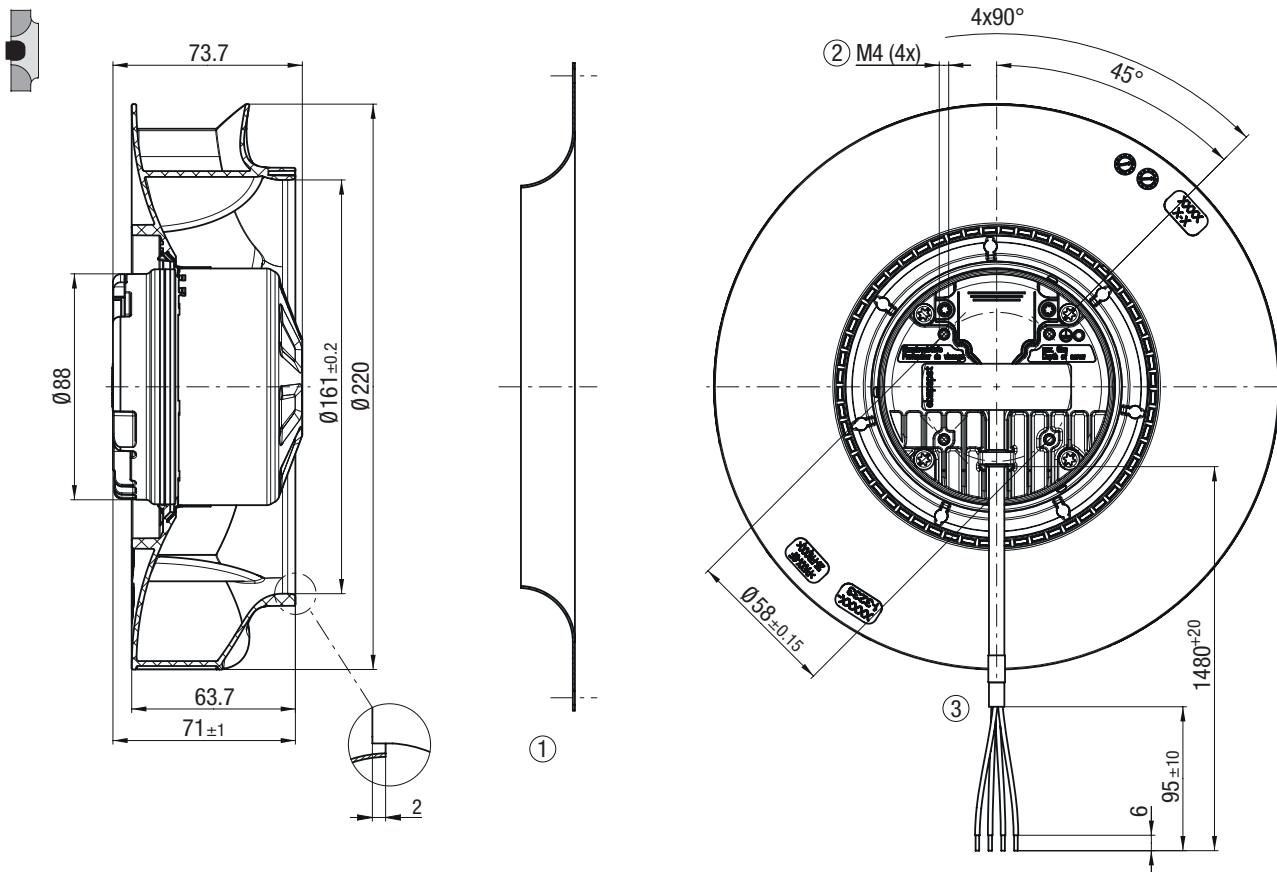

- ① **Accessory part:** Inlet ring 09609-2-4013, not included in scope of delivery  
Dimensions: see "Accessories" chapter
- ② **Max. clearance of screw:** max. 6 mm
- ③ **Cable:** 4x BETAtrans<sup>®</sup> GKW R 0.75 mm<sup>2</sup>, 4x crimped splices

**Pin assignment:** see connection diagram



## B R3G220RY90P1 (Centrifugal fan)

Dimensions in mm

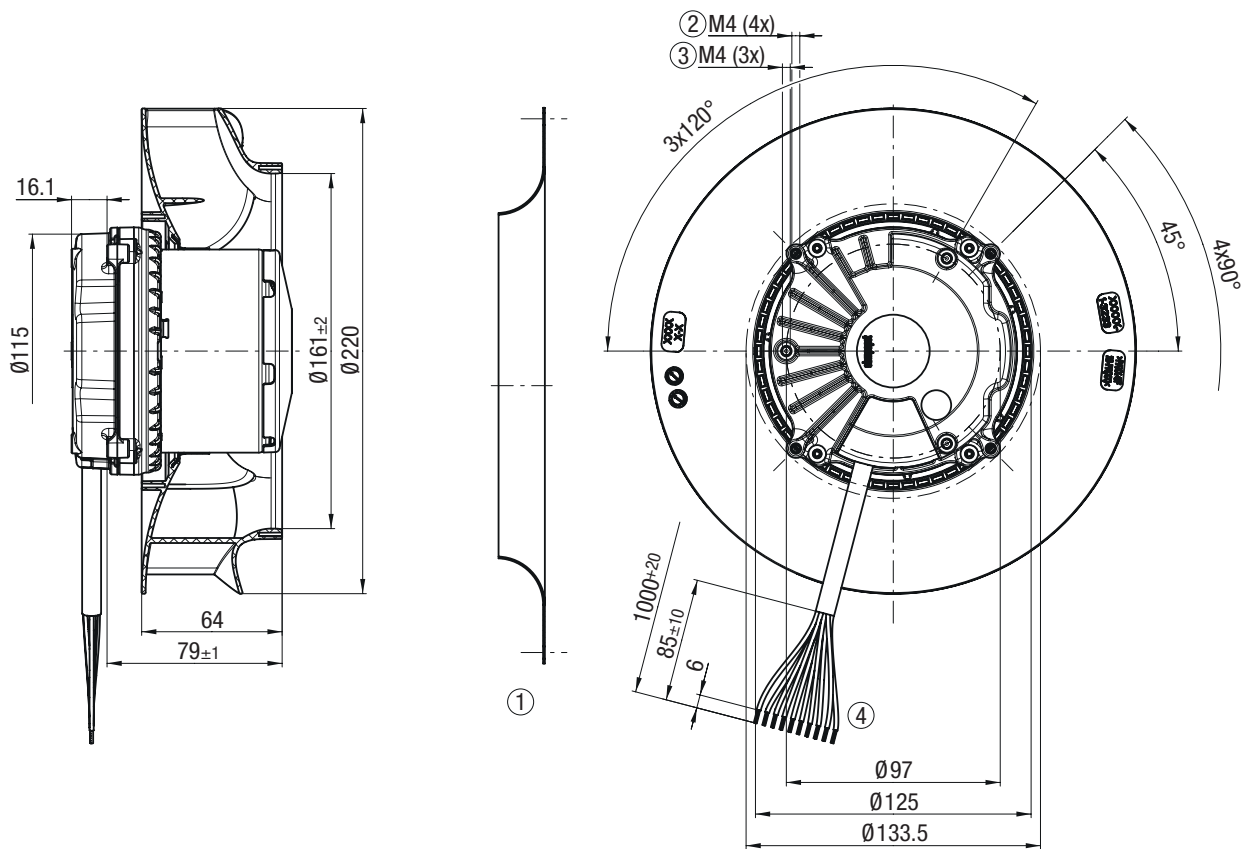

① Accessory part: Inlet ring 09609-2-4013, not included in scope of delivery

Dimensions: see "Accessories" chapter

② Max. clearance of screw: max. 10 mm

③ Max. clearance of screw: max. 8 mm

④ Cable (halogen-free): BETAtans<sup>®</sup> GKW Flex R, 10G 1.0 mm<sup>2</sup>, 10x crimped splices

Pin assignment: see connection diagram

# EC / DC centrifugal fans

backward curved,  $\varnothing$  250 mm



### Material/surface

- Impeller: PA66 plastic, black
- Rotor: Painted black/galvanized
- Electronics housing: Die-cast aluminium
- Support structure: Aluminium
- Inlet ring: Sheet steel, galvanized

### Mechanical data

- Direction of rotation: Clockwise viewed toward rotor
- Mode: Continuous operation (S1)
- Mounting: Maintenance-free ball bearings
- Cable exit: lateral

### Standards and approvals

- Conformity with standards: see page 6
- Approvals: EAC

on Page 32	Drawings
on Page 182	Accessories
on Page 192	Connection diagrams and technical features
on Page 204	Technical parameters & scope
More at	<a href="http://www.ebmpapst.com">www.ebmpapst.com</a>

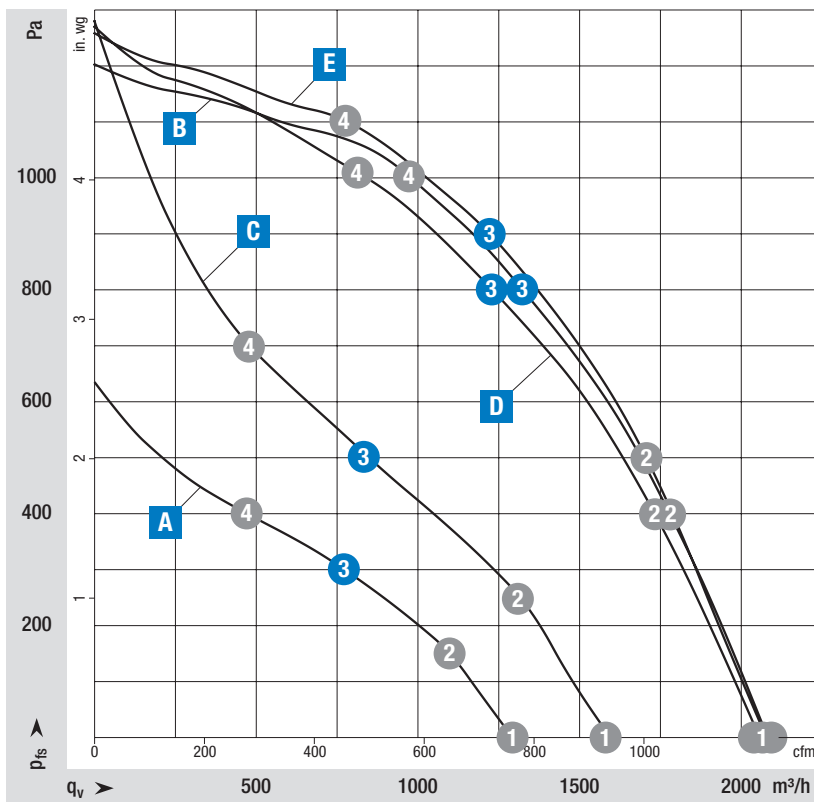

#### Measuring requirements

Air performance measured according to: ISO 5801, installation category A, with ebm-papst inlet ring without contact protection.  
 Intake-side sound level:  $L_{wA}$  according to ISO 13347,  $L_{wA}$  measured at 1 m distance from fan axis. The values given are only applicable under the specified measuring conditions and may differ depending on the installation conditions. In the event of deviation from the standard configuration, the parameters must be checked in installed condition.

Curve	Operating point	Nominal voltage	Speed n	Max. Input power P <sub>ed</sub>	Max. Input current I	Sound power level L <sub>WA</sub>	Protection class	Installation position	Perm. ambient temp.	Degree of protection	Insulation class	Conn. diagram
		VDC										
Voltage range 16-32 V DC												
A	1	24	2500	120	4,90	75	III	Shaft horizontal or rotor on bottom	-25..+60	Motor: IP 24 KM Electr.: IP 66/69 K	B	BA1)
	2	24	2420	123	5,14	73						
	3	24	<b>2350</b>	<b>130</b>	<b>5,39</b>	<b>69</b>						
	4	24	2420	124	5,16	71						
B	1	24	3860	410	15,8	87	III	Any	-40..+70	Motor: IP 24 KM Electr.: IP 66/69 K	B	BA4)
	2	24	3860	513	19,8	85						
	3	24	<b>3860</b>	<b>568</b>	<b>21,9</b>	<b>81</b>						
	4	24	3860	560	21,6	82						
Voltage range 77-138 V DC												
C	1	110	3195	250	2,30	84	I	Any	-40..+60	IP 6K9K	B	BA5)
	2	110	3045	250	2,30	79						
	3	110	<b>2950</b>	<b>250</b>	<b>2,30</b>	<b>73</b>						
	4	110	3130	250	2,30	78						
D	1	110	3860	447	4,06	86	I	Shaft horizontal or rotor on bottom	-40..+60	IP 55 acc. to EN 60529	F	BA6)
	2	110	3815	510	4,64	83						
	3	110	<b>3800</b>	<b>540</b>	<b>4,90</b>	<b>80</b>						
	4	110	3840	510	4,63	82						
Nominal voltage range 380-480 V AC												
E	1	400	4000	476	0,78	87	I	Shaft horizontal or rotor on bottom	-40..+70	IP 55 acc. to EN 60529	F	BA7)
	2	400	4000	560	0,92	84						
	3	400	<b>4000</b>	<b>595</b>	<b>0,95</b>	<b>82</b>						
	4	400	4000	537	0,87	86						

Values set in blue are nominal data at operating point with maximum load.

Subject to change

Curve	Centrifugal fan		with support structure	
	Part number	Weight kg	Part number	Weight kg
A	R1G250RC8781	2,00	-----	-----
B	R3G250RU2781	2,80	K3G250RU2781	8,70
C	R3G250RY90P1	2,30	-----	-----
D	R3G250RR09P1	4,10	K3G250RR09P1	9,20
E	R3G250RR04N1	4,60	K3G250RR04N1	11,70

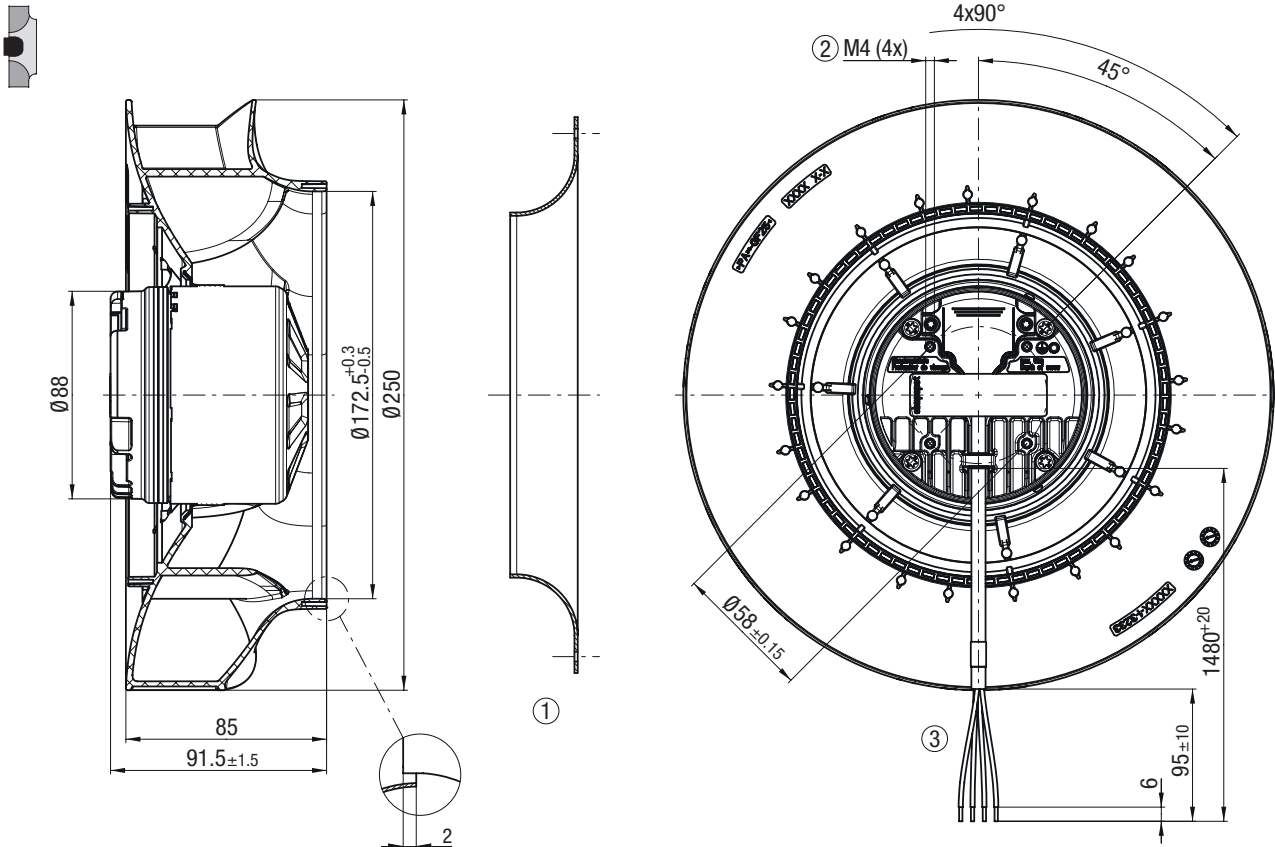

- ① Accessory part: Inlet ring 96359-2-4013, not included in scope of delivery  
Dimensions: see "Accessories" chapter
- ② Max. clearance of screw: max. 6 mm
- ③ Cable: 4x BETrans<sup>®</sup> GKW R 0.75 mm<sup>2</sup>, 4x crimped splices

Pin assignment: see connection diagram

**B R3G250RU2781 (Centrifugal fan)**

Dimensions in mm

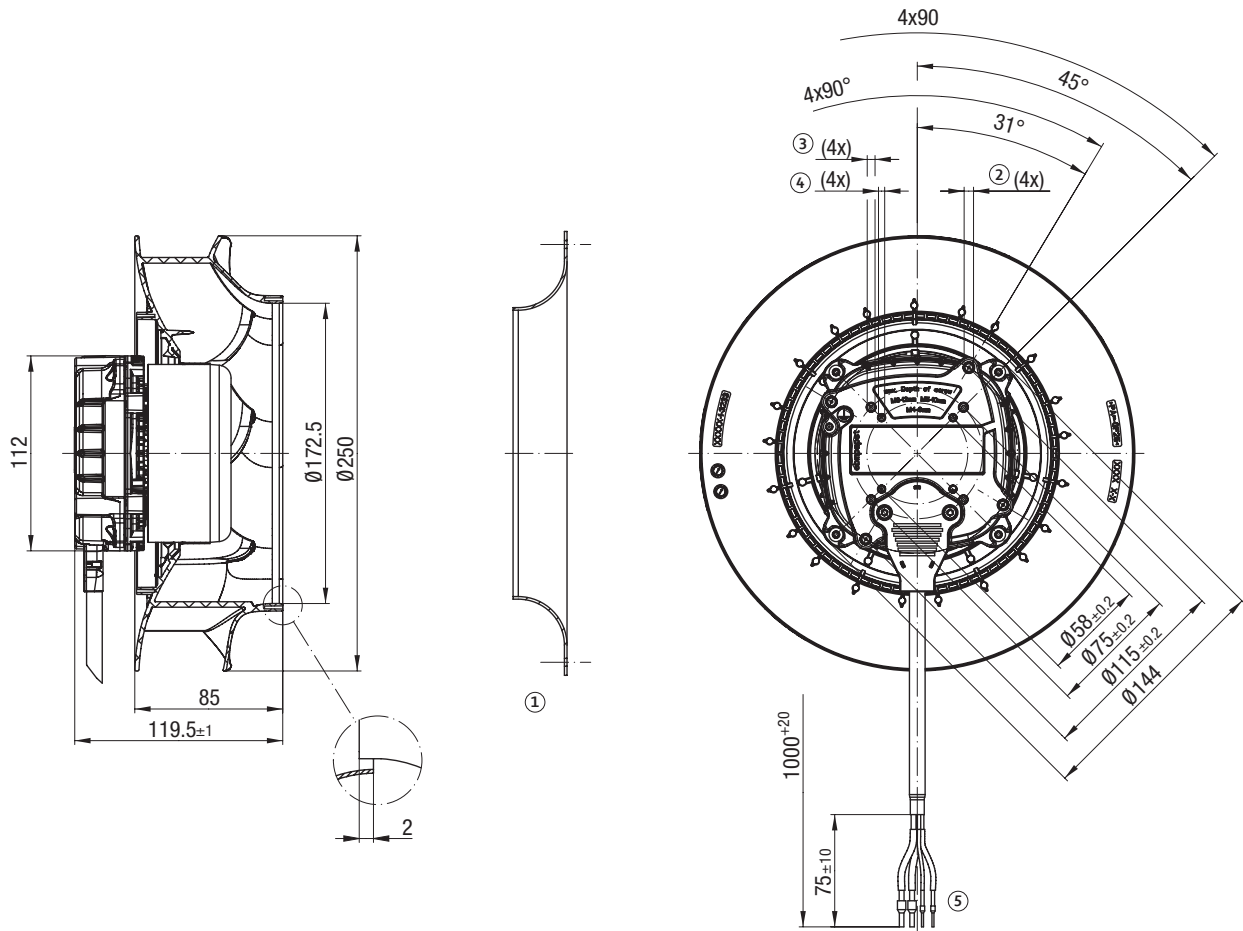

**B K3G250RU2781 (Centrifugal fan with support structure)**

Dimensions in mm

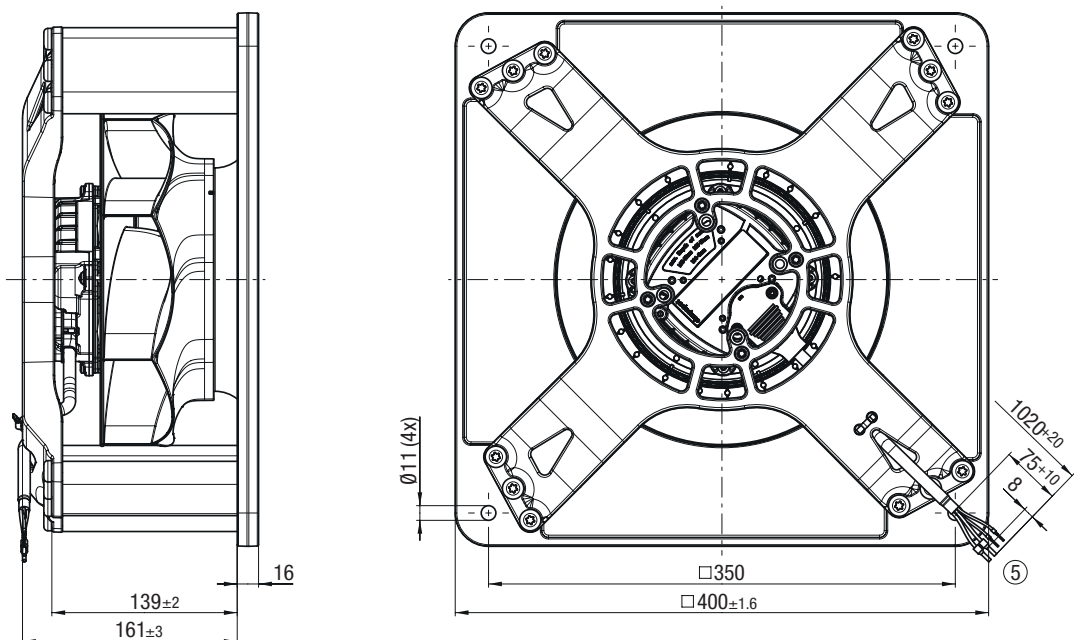

- ① **Accessory part:** Inlet ring 96359-2-4013, not included in scope of delivery  
Dimensions: see "Accessories" chapter
- ② **Max. clearance of screw:** max. 12 mm, tapping hole ready for self-tapping M6 screw
- ③ **Max. clearance of screw:** max. 10 mm, tapping hole ready for self-tapping M5 screw
- ④ **Max. clearance of screw:** max. 8 mm, tapping hole ready for self-tapping M4 screw
- ⑤ **Cable (halogen-free):** 2x BETAtrans® GKW R 2.5 mm<sup>2</sup>, 2x crimped ferrules  
2x BETAtrans® GKW R 1.0 mm<sup>2</sup>, 2x crimped ferrules

Pin assignment: see connection diagram

Mounting Dimensions for centrifugal modules:  
see "Accessories" chapter



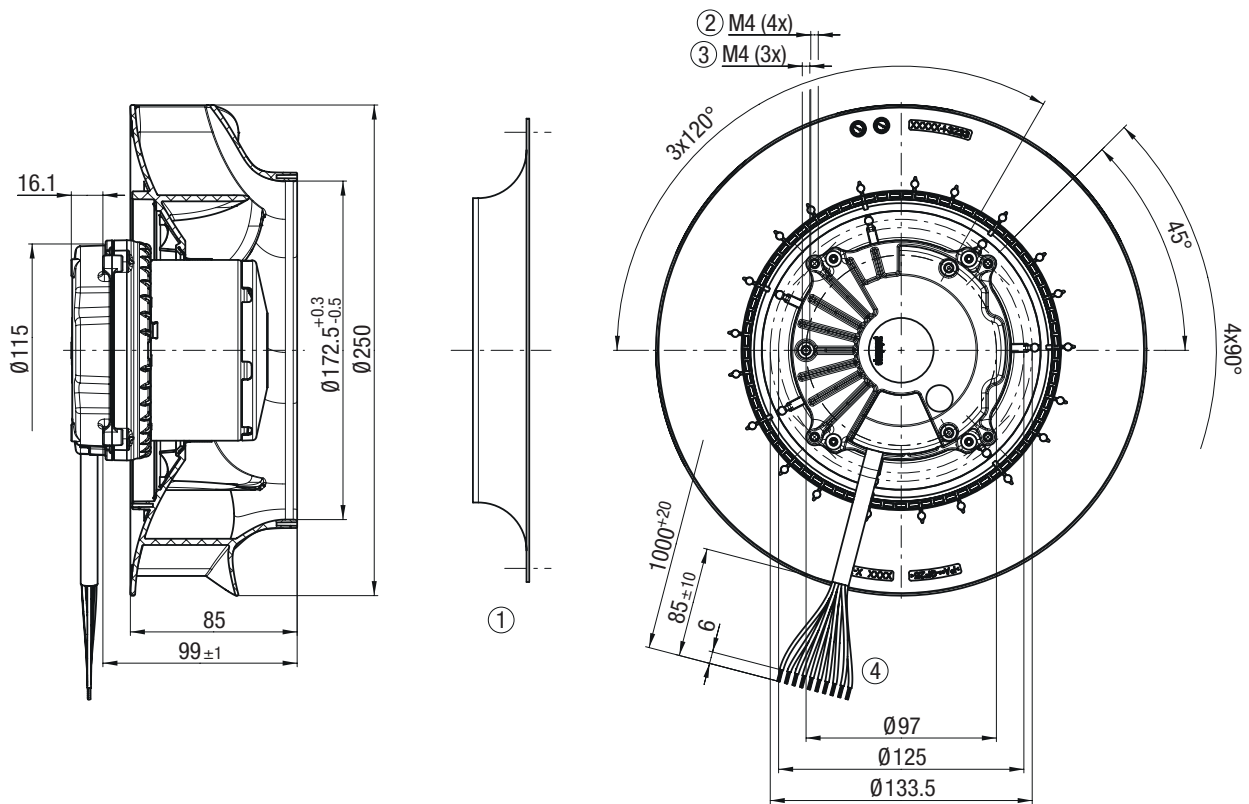

- ① Accessory part: Inlet ring 96359-2-4013, not included in scope of delivery  
Dimensions: see "Accessories" chapter
- ② Max. clearance of screw: max. 10 mm
- ③ Max. clearance of screw: max. 8 mm
- ④ Cable (halogen-free): BETAtans<sup>®</sup> GKW Flex R, 10G 1.0 mm<sup>2</sup>, 10x crimped splices

Pin assignment: see connection diagram

**D R3G250RR09P1 (Centrifugal fan)**

Dimensions in mm

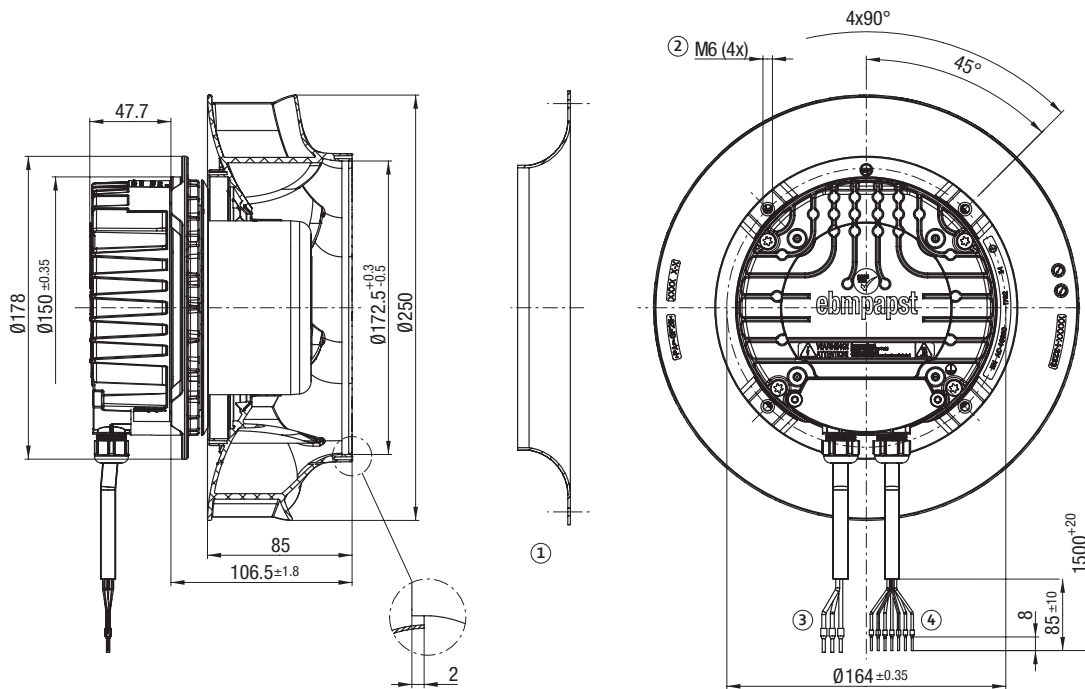

**D K3G250RR09P1 (Centrifugal fan with support structure)**

Dimensions in mm

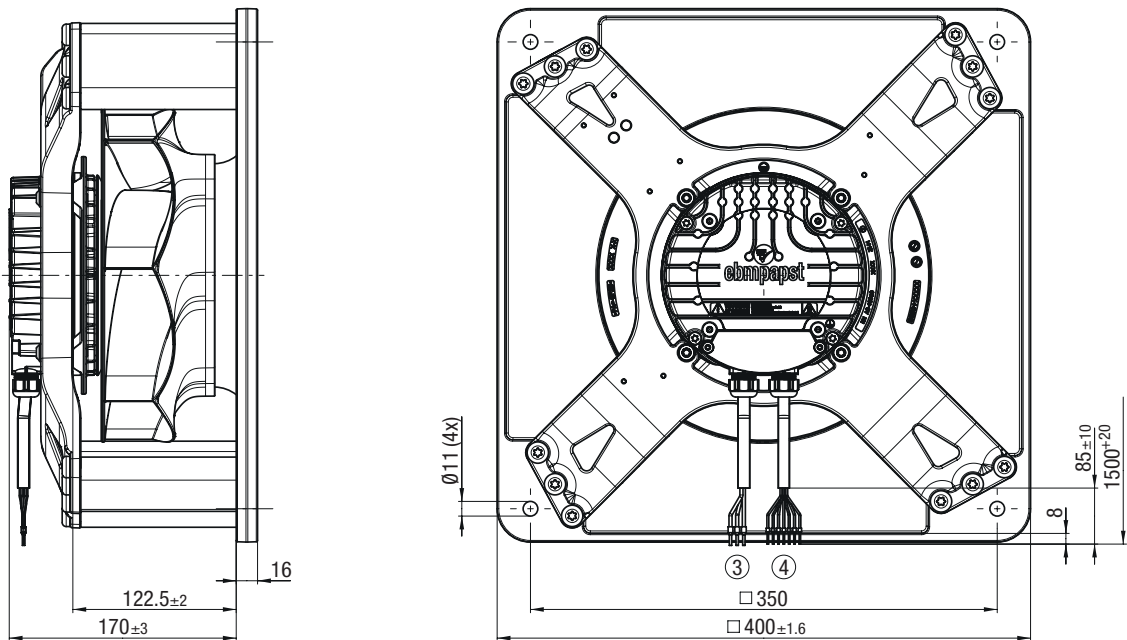

- ① **Accessory part:** Inlet ring 96359-2-4013, not included in scope of delivery  
Dimensions: see "Accessories" chapter
- ② **Max. clearance of screw:** max. 16 mm
- ③ **Cable (halogen-free):** 3x BETAtrans<sup>®</sup> 3 GKW flex, 4G 1.5 mm<sup>2</sup>, 3x crimped ferrules
- ④ **Cable (halogen-free):** 7x BETAtrans<sup>®</sup> 3 GKW flex, 7x 0.5 mm<sup>2</sup>, 7x crimped ferrules

**Pin assignment:** see connection diagram

**Mounting Dimensions for centrifugal modules:**  
see "Accessories" chapter

**E R3G250RR04N1 (Centrifugal fan)**

Dimensions in mm

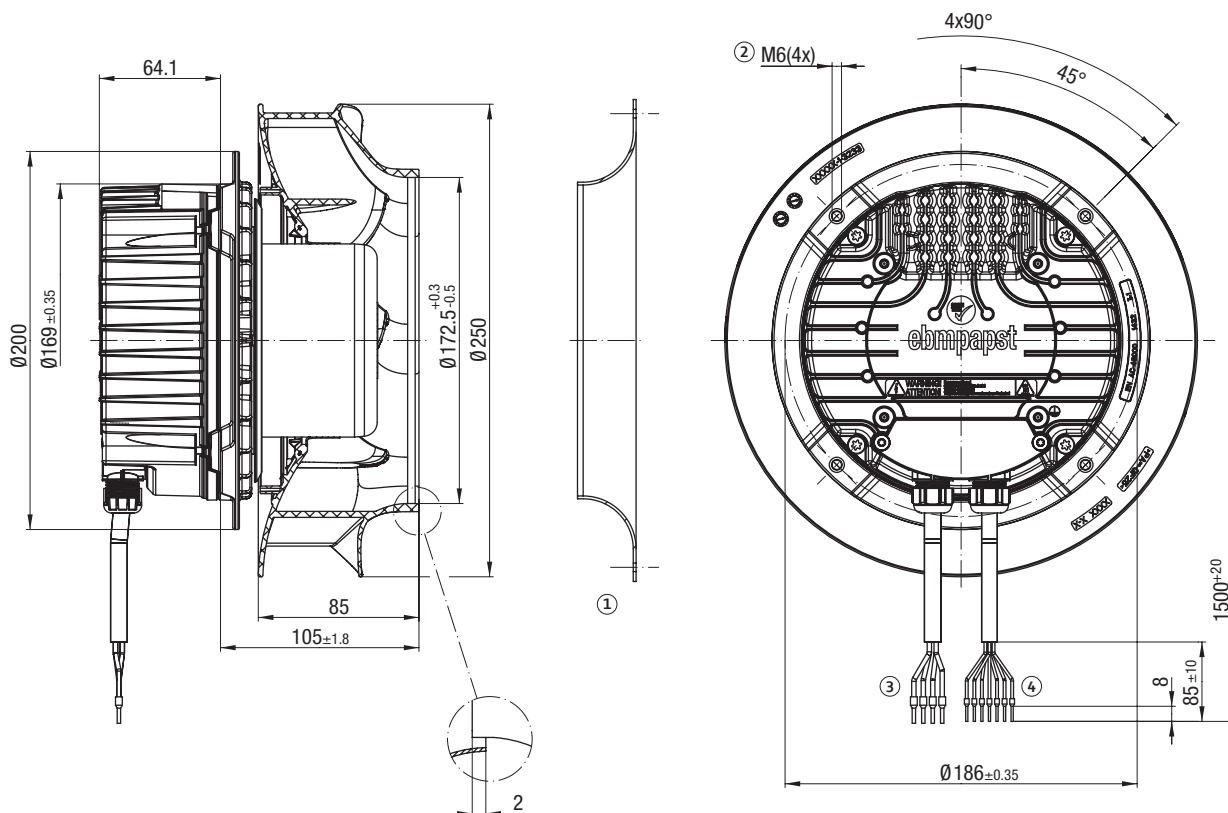

**E K3G250RR04N1 (Centrifugal fan with support structure)**

Dimensions in mm

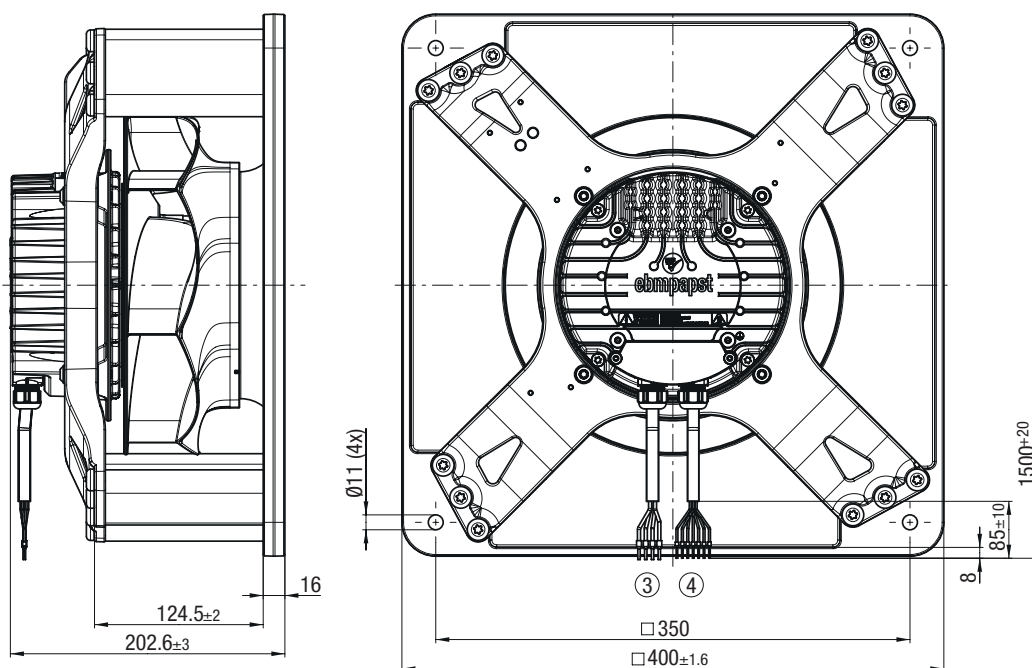

① **Accessory part:** Inlet ring 96359-2-4013, not included in scope of delivery  
Dimensions: see "Accessories" chapter

② **Max. clearance of screw:** max. 16 mm

③ **Cable (halogen-free):** 4x BETAtrans® 3 GKW flex, 4G 1.5 mm<sup>2</sup>, 4x crimped ferrules

④ **Cable (halogen-free):** 7x BETAtrans® 3 GKW flex, 7x 0.5 mm<sup>2</sup>, 7x crimped ferrules

**Pin assignment:** see connection diagram

**Mounting Dimensions for centrifugal modules:**  
see "Accessories" chapter



# EC / DC centrifugal fans

backward curved,  $\varnothing$  250 mm, Aluminium impeller



### Material/surface

- Impeller: Sheet aluminium
- Rotor: Painted black
- Electronics housing: Die-cast aluminium
- Support structure: Aluminium
- Inlet ring: Sheet steel, galvanized

### Mechanical data

- Direction of rotation: Clockwise viewed toward rotor
- Mode: Continuous operation (S1)
- Mounting: Maintenance-free ball bearings
- Cable exit: lateral

### Standards and approvals

- Conformity with standards: see page 6
- Approvals: EAC

on Page 40	Drawings
on Page 182	Accessories
on Page 192	Connection diagrams and technical features
on Page 204	Technical parameters & scope
More at	<a href="http://www.ebmpapst.com">www.ebmpapst.com</a>

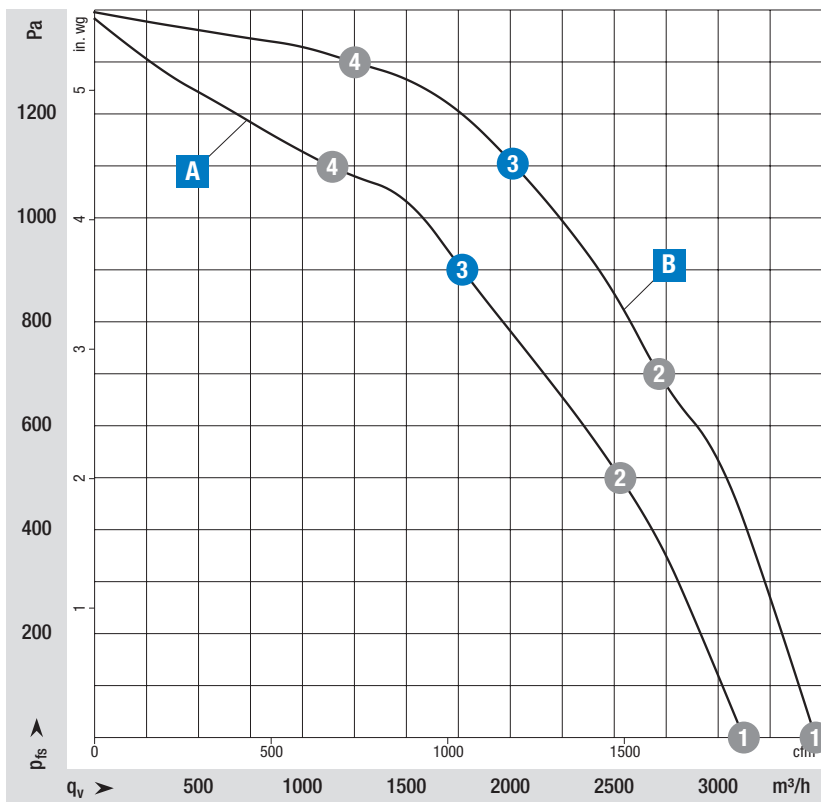

#### Measuring requirements

Air performance measured according to: ISO 5801, installation category A, with ebm-papst inlet ring without contact protection.  
 Intake-side sound level:  $L_{pA}$  according to ISO 13347,  $L_{pA}$  measured at 1 m distance from fan axis. The values given are only applicable under the specified measuring conditions and may differ depending on the installation conditions. In the event of deviation from the standard configuration, the parameters must be checked in installed condition.

Curve	Operating point	Nominal voltage	Speed n	Max. Input power P <sub>ed</sub>	Max. Input current I	Sound power level L <sub>WA</sub>	Protection class	Installation position	Perm. ambient temp.	Degree of protection	Insulation class	Conn. diagram
		VDC	rpm	W	A	dB(A)						
Voltage range 77-138 V DC												
<b>A</b>	①	110	3695	671	6,10	85	I	Shaft horizontal or rotor on bottom	-40..+60	IP 55 acc. to EN 60529	F	BA6)
	②	110	3635	765	6,95	81						
	③	<b>110</b>	<b>3600</b>	<b>800</b>	<b>7,30</b>	<b>79</b>						
	④	110	3660	759	6,90	86						
Nominal voltage range 380-480 V AC												
<b>B</b>	①	400	4000	781	1,26	87	I	Shaft horizontal or rotor on bottom	-40..+60	IP 55 acc. to EN 60529	F	BA7)
	②	400	4000	981	1,55	82						
	③	<b>400</b>	<b>4000</b>	<b>1050</b>	<b>1,60</b>	<b>81</b>						
	④	400	4000	953	1,52	89						

Values set in blue are nominal data at operating point with maximum load.

Subject to change

Curve	Centrifugal fan		with support structure	
	Part number	Weight kg	Part number	Weight kg
<b>A</b>	R3G250BB09S1	5,10	K3G250BB09S1	11,30
<b>B</b>	R3G250BB01N1	5,10	K3G250BB01N1	11,30



**A** R3G250BB09S1 (Centrifugal fan)

Dimensions in mm

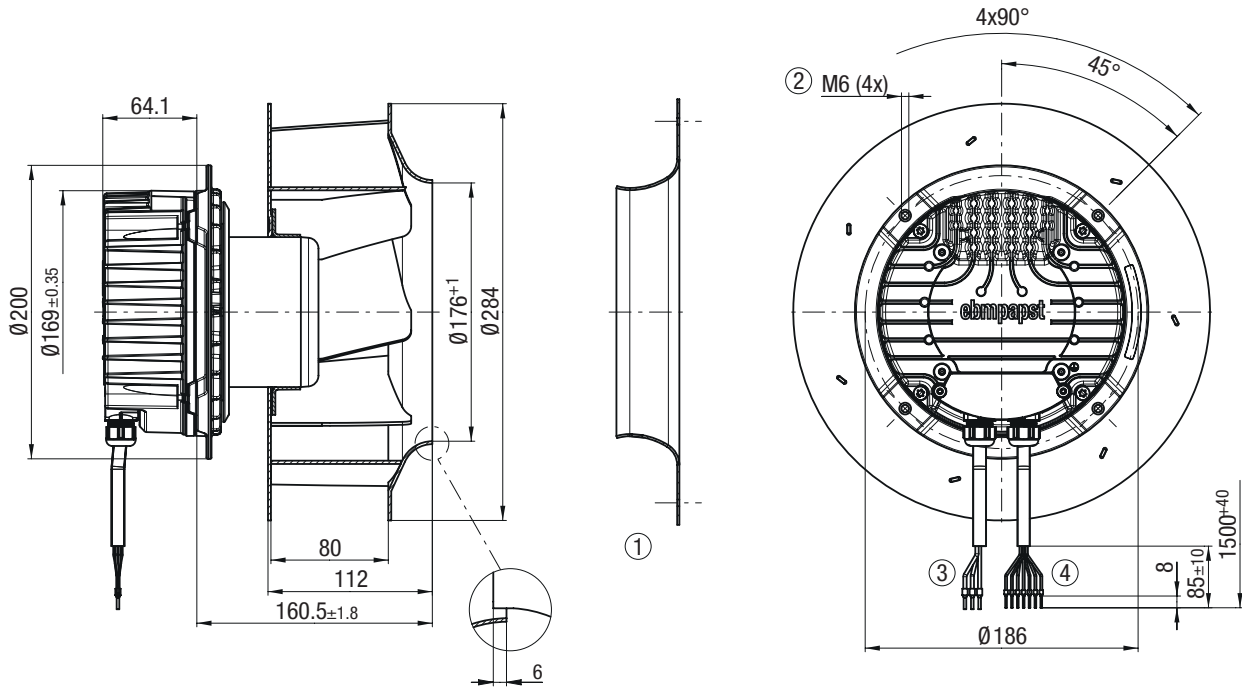

**A** K3G250BB09S1 (Centrifugal fan with support structure)

Dimensions in mm

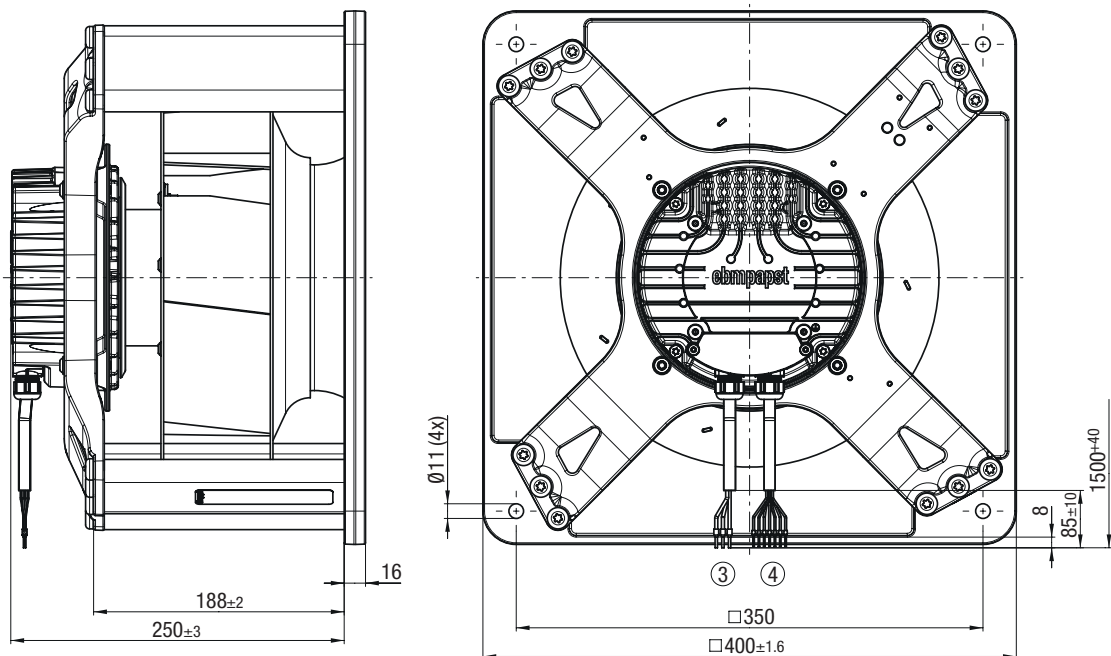

- ① **Accessory part:** Inlet ring 25070-2-4013, not included in scope of delivery  
Dimensions: see "Accessories" chapter
- ② **Max. clearance of screw:** max. 16 mm
- ③ **Cable (halogen-free):** 3x BETAtrans<sup>®</sup> 3 GW flex, 4G 1.5 mm<sup>2</sup>, 3x crimped ferrules
- ④ **Cable (halogen-free):** 7x BETAtrans<sup>®</sup> 3 GW flex, 7x 0.5 mm<sup>2</sup>, 7x crimped ferrules

**Pin assignment:** see connection diagram

**Mounting Dimensions for centrifugal modules:**  
see "Accessories" chapter

**B R3G250BB01N1 (Centrifugal fan)**

Dimensions in mm

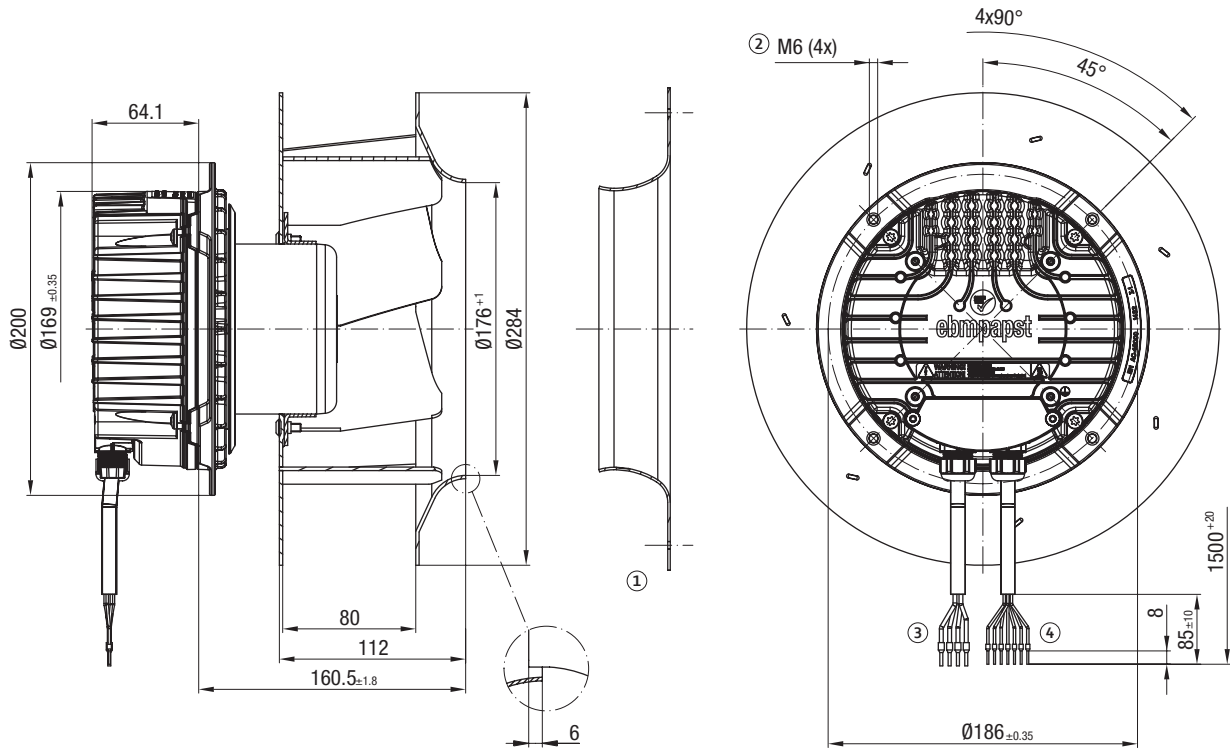

**B K3G250BB01N1 (Centrifugal fan with support structure)**

Dimensions in mm

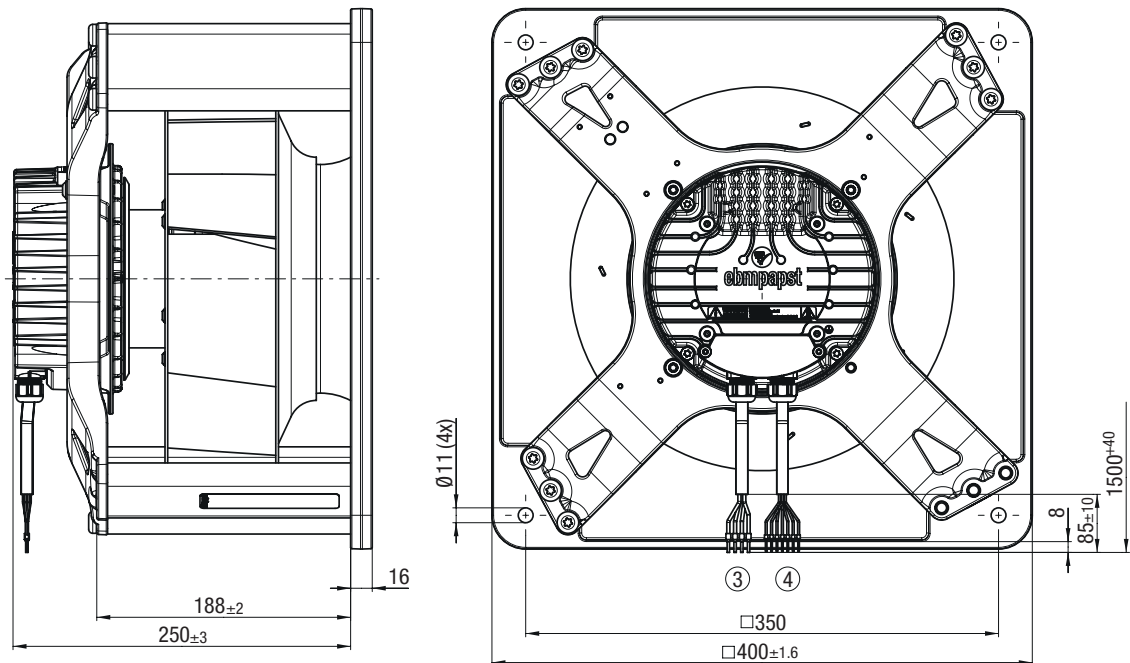

- ① **Accessory part:** Inlet ring 25070-2-4013, not included in scope of delivery  
Dimensions: see "Accessories" chapter
- ② **Max. clearance of screw:** max. 16 mm
- ③ **Cable (halogen-free):** 4x BETAtans<sup>®</sup> 3 GKW flex, 4G 1.5 mm<sup>2</sup>, 4x crimped ferrules
- ④ **Cable (halogen-free):** 7x BETAtans<sup>®</sup> 3 GKW flex, 7x 0.5 mm<sup>2</sup>, 7x crimped ferrules

**Pin assignment:** see connection diagram

**Mounting Dimensions for centrifugal modules:**  
see "Accessories" chapter

# EC / DC centrifugal fans

backward curved,  $\varnothing$  280 mm



### Material/surface

- Impeller: PA66 plastic, black
- Rotor: Painted black
- Electronics housing: Die-cast aluminium
- Support structure: Aluminium
- Inlet ring: Sheet steel, galvanized

### Mechanical data

- Direction of rotation: Clockwise viewed toward rotor
- Mode: Continuous operation (S1)
- Mounting: Maintenance-free ball bearings
- Cable exit: lateral

### Standards and approvals

- Conformity with standards: see page 6
- Approvals: EAC

on Page 44	Drawings
on Page 182	Accessories
on Page 192	Connection diagrams and technical features
on Page 204	Technical parameters & scope
More at	<a href="http://www.ebmpapst.com">www.ebmpapst.com</a>

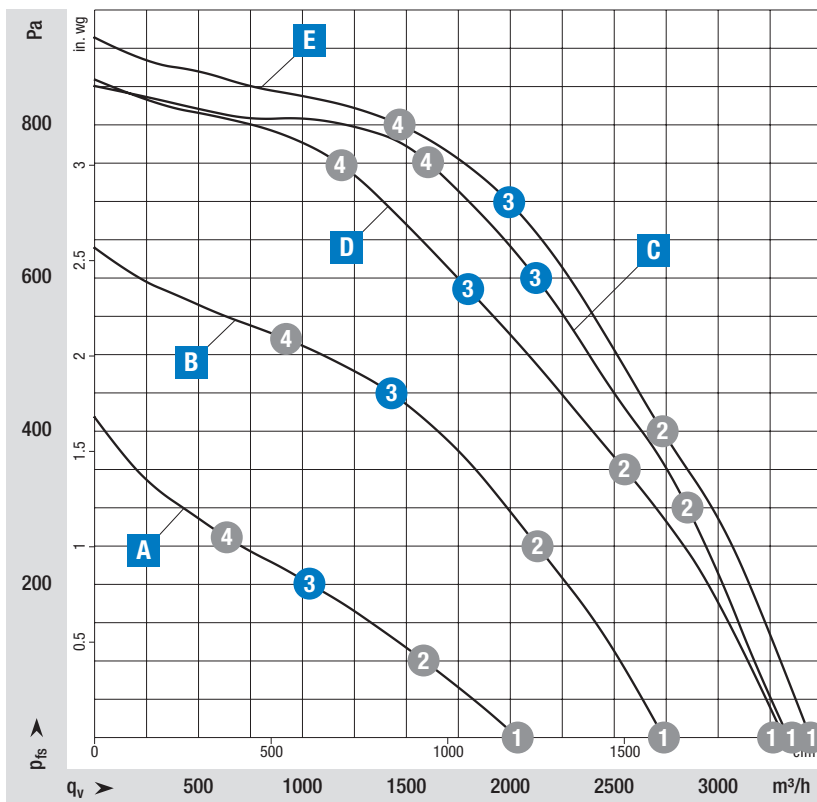

#### Measuring requirements

Air performance measured according to: ISO 5801, installation category A, with ebm-papst inlet ring without contact protection.  
Intake-side sound level:  $L_{wA}$  according to ISO 13347,  $L_{pA}$  measured at 1 m distance from fan axis. The values given are only applicable under the specified measuring conditions and may differ depending on the installation conditions. In the event of deviation from the standard configuration, the parameters must be checked in installed condition.

Curve	Operating point	Nominal voltage	Speed n	Max. Input power P <sub>ed</sub>	Max. Input current I	Sound power level L <sub>WA</sub>	Protection class	Installation position	Perm. ambient temp.	Degree of protection	Insulation class	Conn. diagram
		VDC										
Voltage range 16-32 V DC												
A	1	24	1700	105	4,40	70	III	Any	-25..+60	Motor: IP 24 KM Electr.: IP 66/69 K	B	BA1)
	2	24	1595	111	4,60	65						
	3	24	1550	112	4,68	60						
	4	24	1635	109	4,52	65						
B	1	24	2350	252	10,5	80	III	Any	-40..+70	Motor: IP 24 KM Electr.: IP 66/69 K	B	BA3)
	2	24	2280	298	12,4	75						
	3	24	2265	304	12,6	73						
	4	24	2305	280	11,7	74						
C	1	24	2830	460	18,0	85	III	Shaft horizontal or rotor on bottom	-40..+70	Motor: IP 24 KM Electr.: IP 66/69 K	B	BA4)
	2	24	2810	584	22,4	81						
	3	24	2810	645	24,8	77						
	4	24	2835	623	23,9	77						
Voltage range 77-138 V DC												
D	1	110	2810	436	4,00	84	I	Shaft horizontal or rotor on bottom	-40..+60	IP 55 acc. to EN 60529	F	BA6)
	2	110	2715	495	4,50	77						
	3	110	2635	495	4,50	73						
	4	110	2760	491	4,50	75						
Nominal voltage range 380-480 V AC												
E	1	400	2900	473	0,81	86	I	Shaft horizontal or rotor on bottom	-40..+60	IP 55 acc. to EN 60529	F	BA7)
	2	400	2900	599	1,01	80						
	3	400	2900	640	1,05	76						
	4	400	2900	587	0,97	77						

Values set in blue are nominal data at operating point with maximum load.

Subject to change

Curve	Centrifugal fan		with support structure	
	Part number	Weight kg	Part number	Weight kg
A	R1G280RC7181	2,30	-----	-----
B	R3G280RU2681	3,00	K3G280RU2681	9,20
C	R3G280RU6582	3,00	K3G280RU6582	9,20
D	R3G280RR10P1	4,20	K3G280RR10P1	9,60
E	R3G280RR05N1	4,90	K3G280RR05N1	11,70

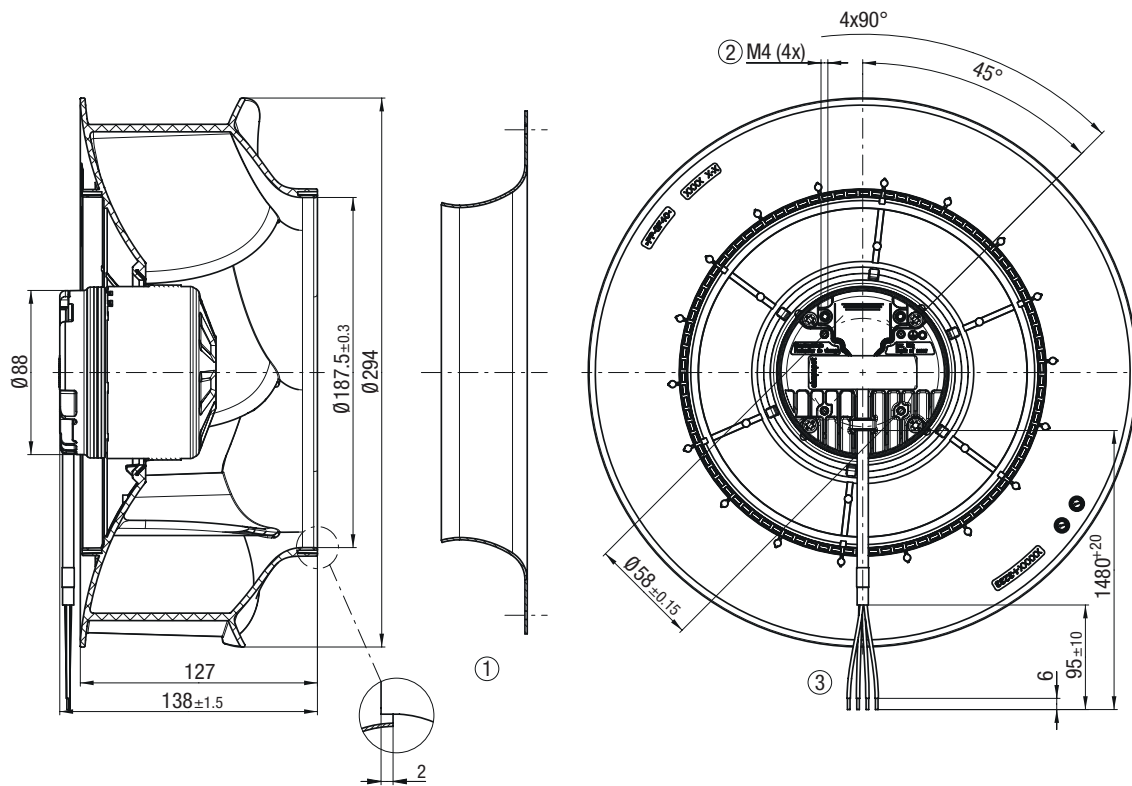

- ① Accessory part: Inlet ring 28000-2-4013, not included in scope of delivery  
Dimensions: see "Accessories" chapter
- ② Max. clearance of screw: max. 6 mm
- ③ Cable: 4x BETAtrans<sup>®</sup> GKW R 0.75 mm<sup>2</sup>, 4x crimped splices

Pin assignment: see connection diagram

**B R3G280RU2681 (Centrifugal fan)**

Dimensions in mm

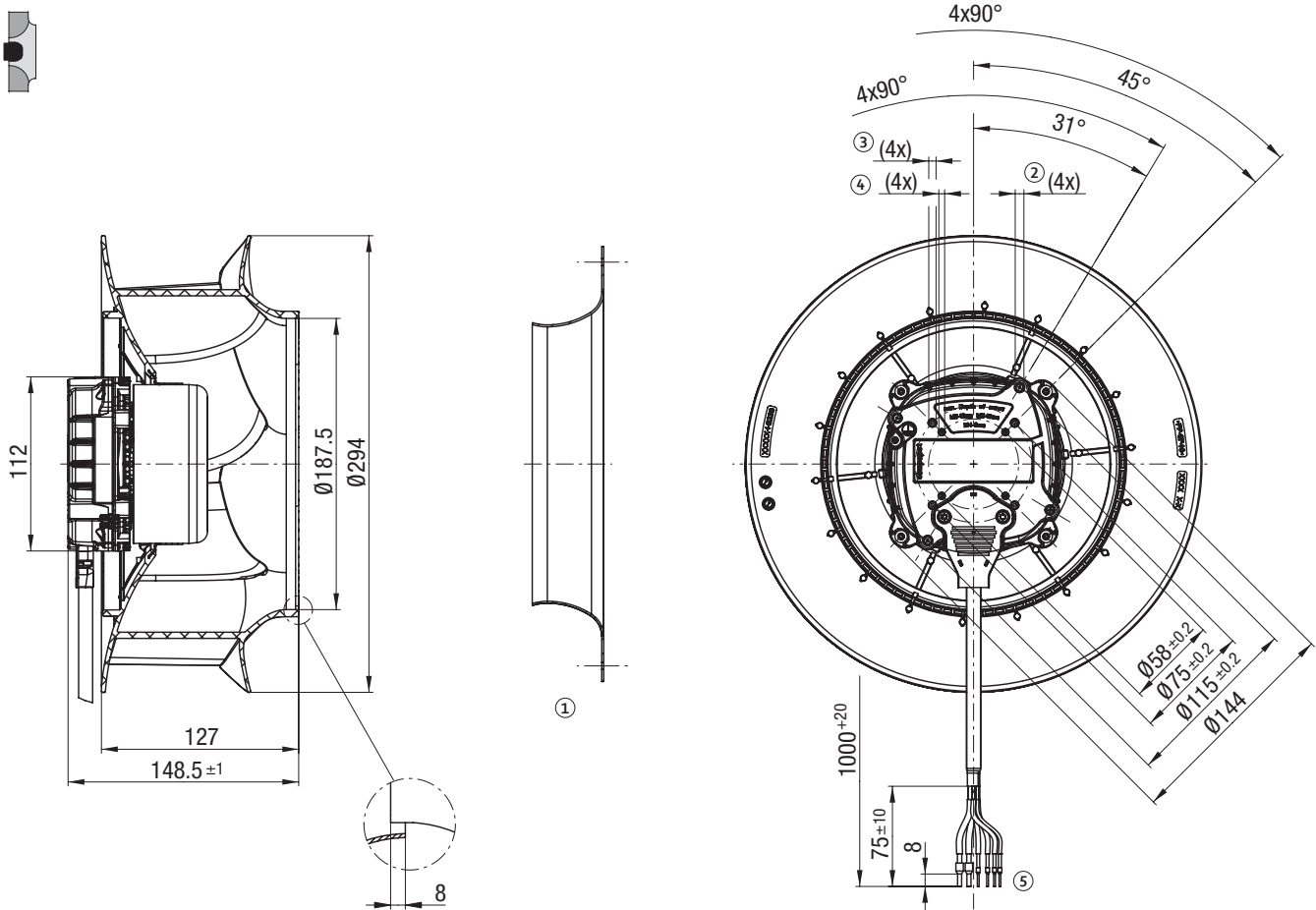

**B K3G280RU2681 (Centrifugal fan with support structure)**

Dimensions in mm

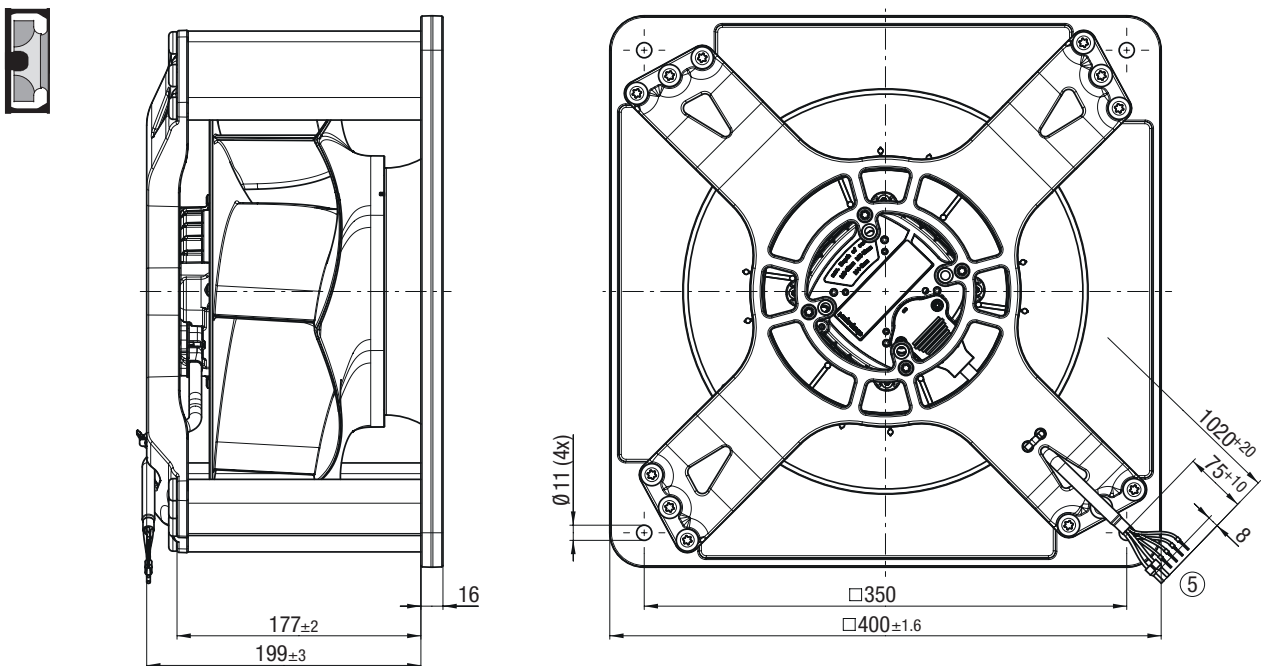

- ① **Accessory part:** Inlet ring 28000-2-4013, not included in scope of delivery  
Dimensions: see "Accessories" chapter
- ② **Max. clearance of screw:** max. 12 mm, tapping hole ready for self-tapping M6 screw
- ③ **Max. clearance of screw:** max. 10 mm, tapping hole ready for self-tapping M5 screw
- ④ **Max. clearance of screw:** max. 8 mm, tapping hole ready for self-tapping M4 screw
- ⑤ **Cable (halogen-free):** 2x BETAtrans® GKW R 2.5 mm<sup>2</sup>, 2x crimped ferrules  
4x BETAtrans® GKW R 1.0 mm<sup>2</sup>, 4x crimped ferrules

**Pin assignment:** see connection diagram

**Mounting Dimensions for centrifugal modules:**  
see "Accessories" chapter

**C** R3G280RU6582 (Centrifugal fan)

Dimensions in mm

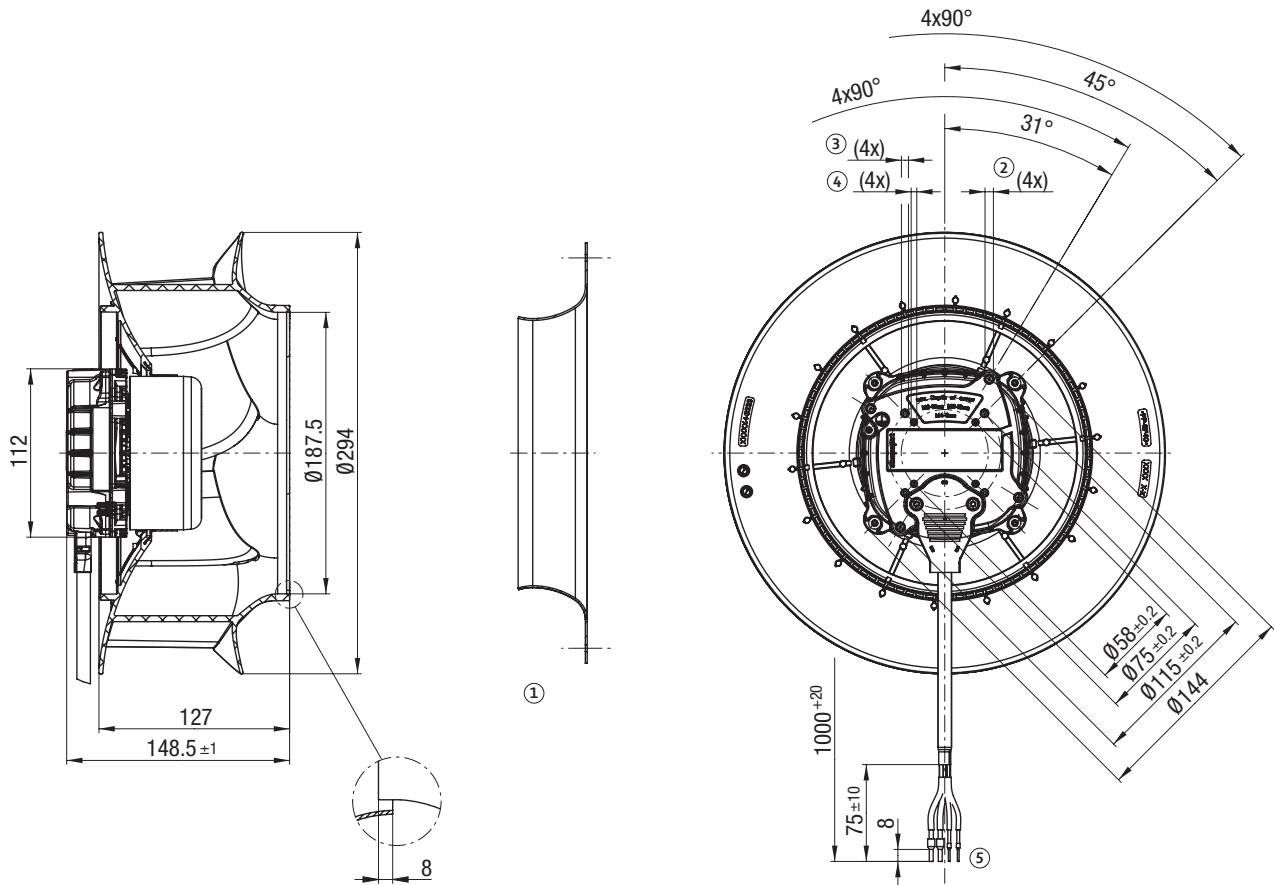

**C** K3G280RU6582 (Centrifugal fan with support structure)

Dimensions in mm

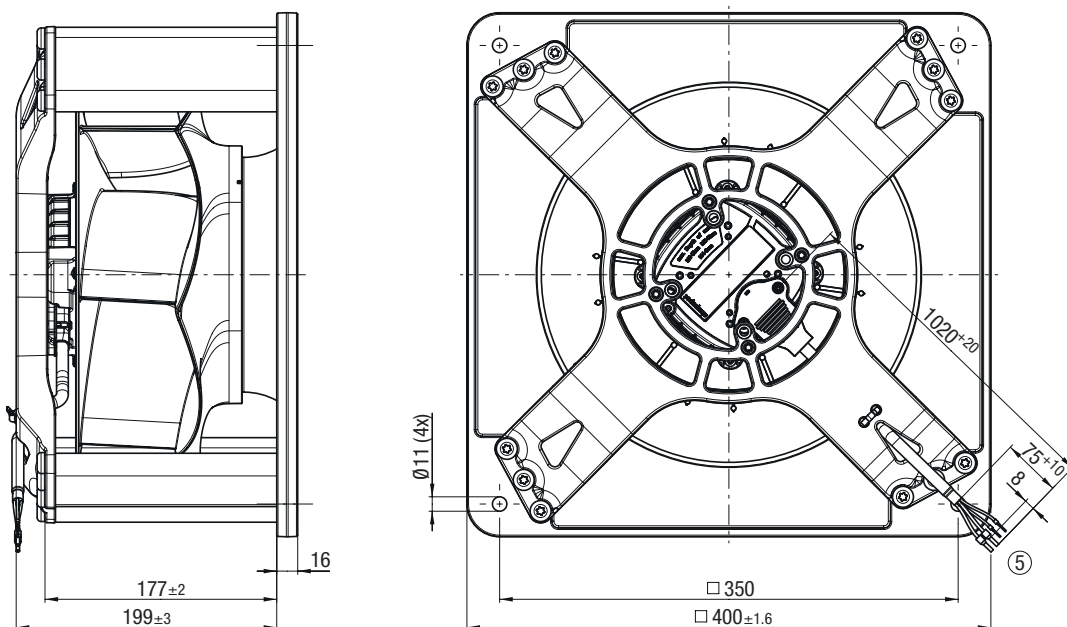

- ① **Accessory part:** Inlet ring 28000-2-4013, not included in scope of delivery  
Dimensions: see "Accessories" chapter
- ② **Max. clearance of screw:** max. 12 mm, tapping hole ready for self-tapping M6 screw
- ③ **Max. clearance of screw:** max. 10 mm, tapping hole ready for self-tapping M5 screw
- ④ **Max. clearance of screw:** max. 8 mm, tapping hole ready for self-tapping M4 screw
- ⑤ **Cable (halogen-free):** 2x BETAtrans® GKW R 2.5 mm<sup>2</sup>, 2x crimped ferrules  
2x BETAtrans® GKW R 1.0 mm<sup>2</sup>, 2x crimped ferrules

**Pin assignment:** see connection diagram

**Mounting Dimensions for centrifugal modules:**  
see "Accessories" chapter



**D R3G280RR10P1 (Centrifugal fan)**

Dimensions in mm

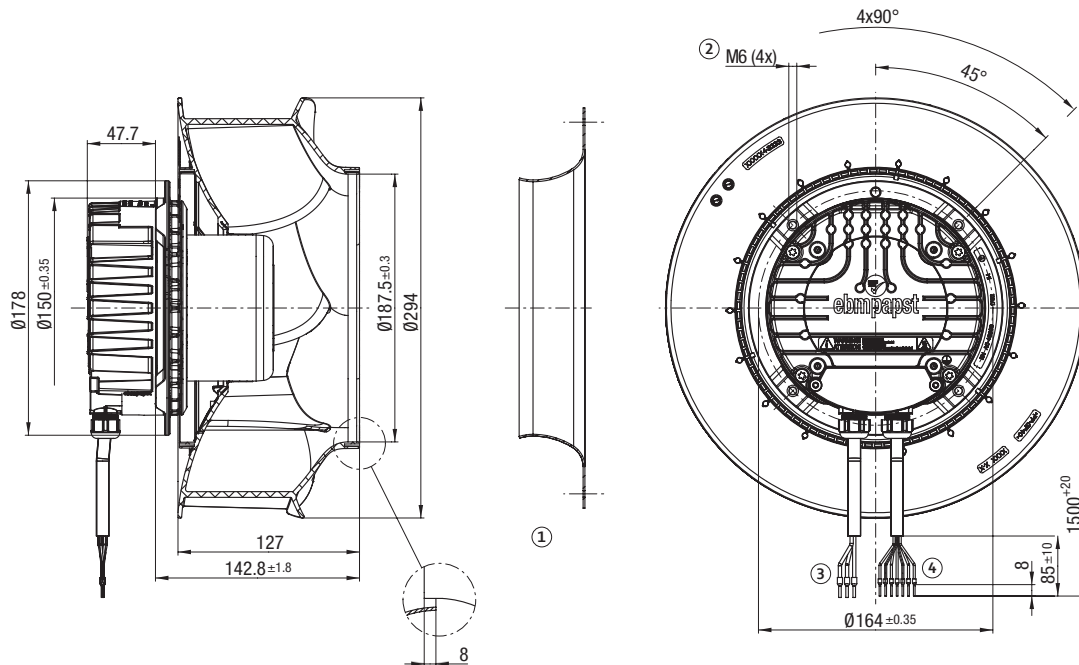

**D K3G280RR10P1 (Centrifugal fan with support structure)**

Dimensions in mm

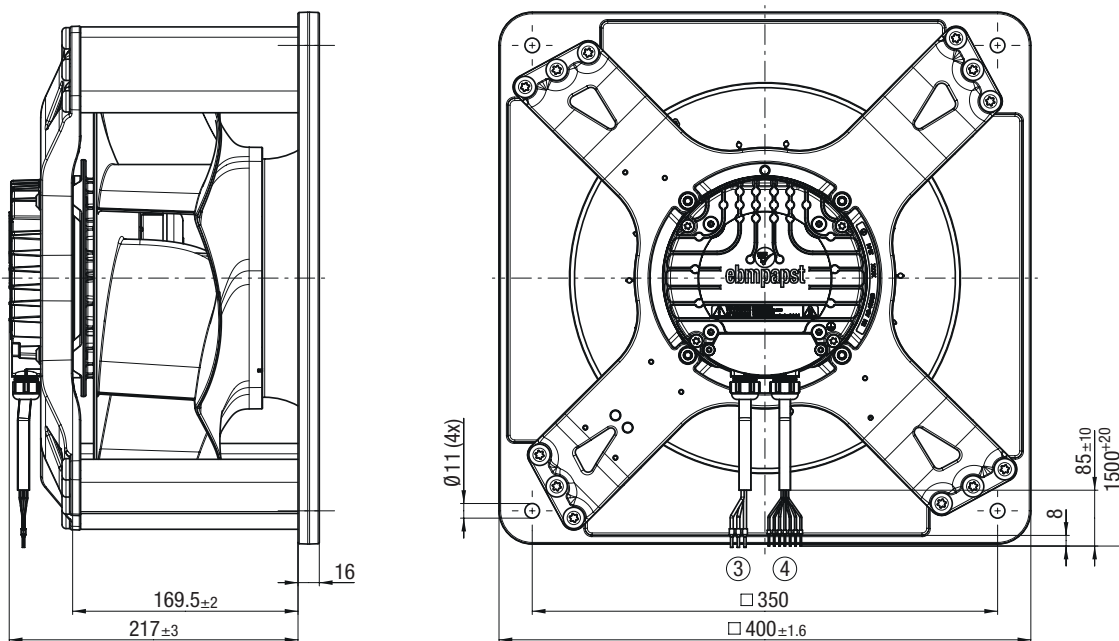

- ① **Accessory part:** Inlet ring 28000-2-4013, not included in scope of delivery  
Dimensions: see "Accessories" chapter
- ② **Max. clearance of screw:** max. 16 mm
- ③ **Cable (halogen-free):** 3x BETAtrans<sup>®</sup> 3 GKW flex, 4G 1.5 mm<sup>2</sup>, 3x crimped ferrules
- ④ **Cable (halogen-free):** 7x BETAtrans<sup>®</sup> 3 GKW flex, 7x 0.5 mm<sup>2</sup>, 7x crimped ferrules

**Pin assignment:** see connection diagram

**Mounting Dimensions for centrifugal modules:**  
see "Accessories" chapter

**E R3G280RR05N1 (Centrifugal fan)**

Dimensions in mm

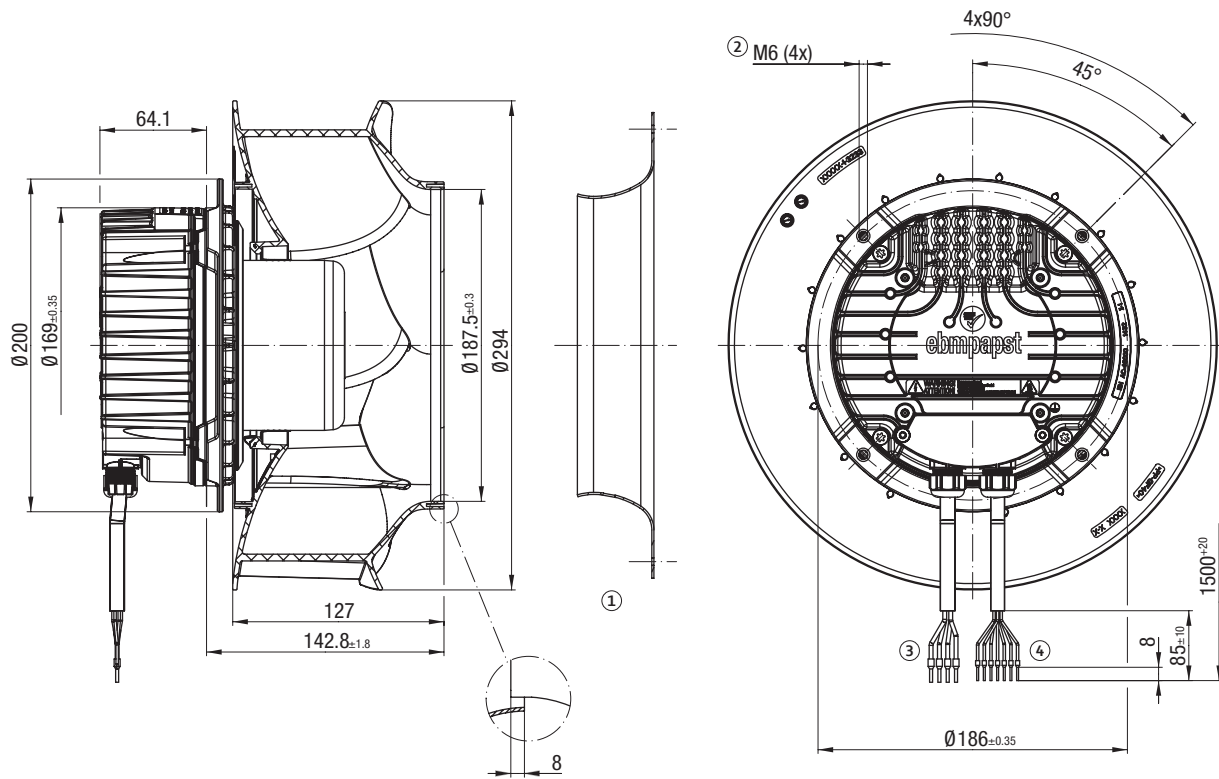

**E K3G280RR05N1 (Centrifugal fan with support structure)**

Dimensions in mm

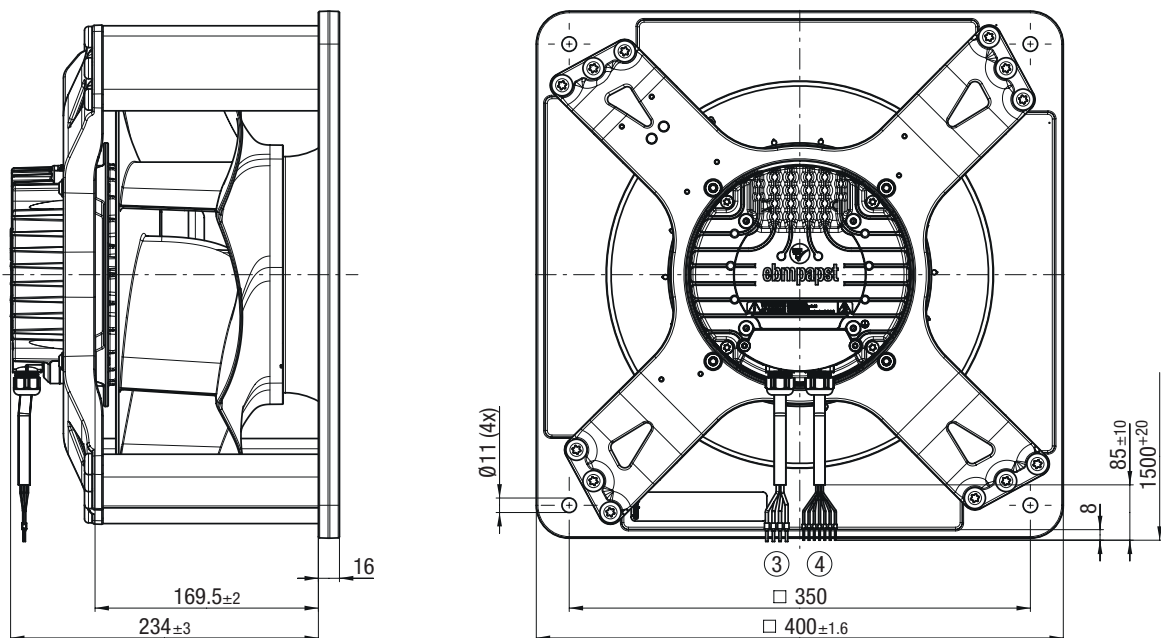

- ① **Accessory part:** Inlet ring 28000-2-4013, not included in scope of delivery  
Dimensions: see "Accessories" chapter
- ② **Max. clearance of screw:** max. 16 mm
- ③ **Cable (halogen-free):** 4x BETAtrans® 3 GKW flex, 4G 1.5 mm<sup>2</sup>, 4x crimped ferrules
- ④ **Cable (halogen-free):** 7x BETAtrans® 3 GKW flex, 7x 0.5 mm<sup>2</sup>, 7x crimped ferrules

**Pin assignment:** see connection diagram

**Mounting Dimensions for centrifugal modules:**  
see "Accessories" chapter



# EC / DC centrifugal fans

backward curved,  $\varnothing$  280 mm, Aluminium impeller



### Material/surface

- Impeller: Sheet aluminium
- Rotor: Painted black
- Electronics housing: Die-cast aluminium
- Support structure: Aluminium
- Inlet ring: Sheet steel, galvanized

### Mechanical data

- Direction of rotation: Clockwise viewed toward rotor
- Mode: Continuous operation (S1)
- Mounting: Maintenance-free ball bearings
- Cable exit: lateral

### Standards and approvals

- Conformity with standards: see page 6
- Approvals: EAC

on Page 52	Drawings
on Page 182	Accessories
on Page 192	Connection diagrams and technical features
on Page 204	Technical parameters & scope
More at	<a href="http://www.ebmpapst.com">www.ebmpapst.com</a>

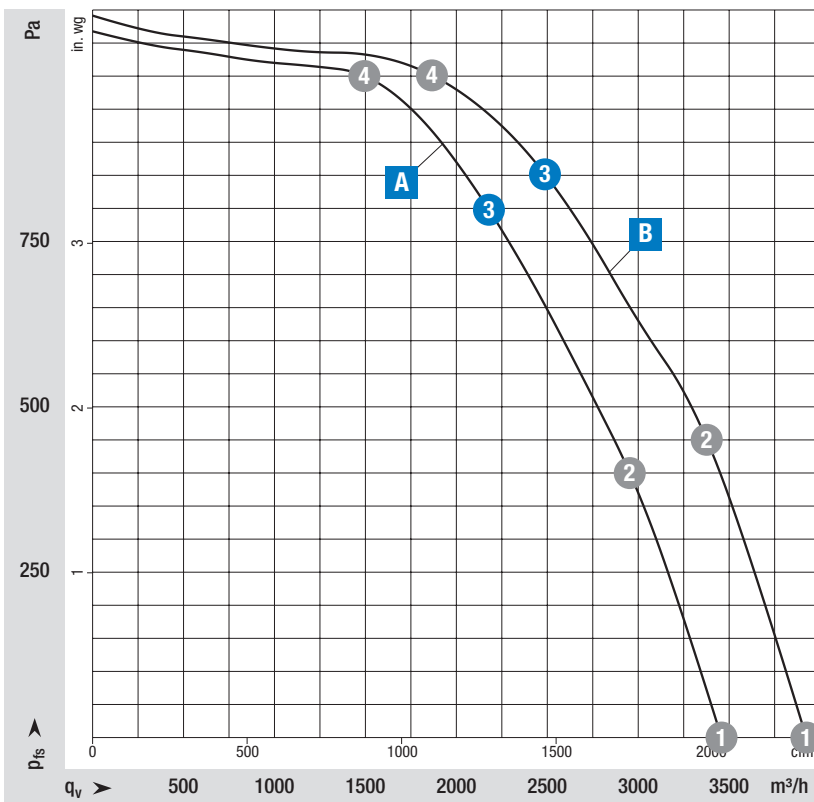

#### Measuring requirements

Air performance measured according to: ISO 5801, installation category A, with ebm-papst inlet ring without contact protection.  
 Intake-side sound level:  $L_{wA}$  according to ISO 13347,  $L_{pA}$  measured at 1 m distance from fan axis. The values given are only applicable under the specified measuring conditions and may differ depending on the installation conditions. In the event of deviation from the standard configuration, the parameters must be checked in installed condition.

Curve	Operating point	Nominal voltage	Speed n	Max. Input power P <sub>ed</sub>	Max. Input current I	Sound power level L <sub>WA</sub>	Protection class	Installation position	Perm. ambient temp.	Degree of protection	Insulation class	Conn. diagram
		VDC	rpm	W	A	dB(A)						
Voltage range 77-138 V DC												
A	1	110	3140	743	6,80	88	I	Shaft horizontal or rotor on bottom	-40..+60	IP 55 acc. to EN 60529	F	BA6)
	2	110	3120	882	8,00	85						
	3	110	3100	920	8,40	82						
	4	110	3140	861	7,80	82						
Nominal voltage range 380-480 V AC												
B	1	400	3140	743	1,21	87	I	Shaft horizontal or rotor on bottom	-40..+60	IP 55 acc. to EN 60529	F	BA7)
	2	400	3140	922	1,47	83						
	3	400	3140	975	1,50	80						
	4	400	3140	931	1,48	82						

Values set in blue are nominal data at operating point with maximum load.

Subject to change

Curve	Centrifugal fan		with support structure	
	Part number	Weight kg	Part number	Weight kg
A	R3G280BD13S1	8,00	K3G280BD13S1	14,40
B	R3G280BC01N1	6,90	K3G280BC01N1	13,30

**A** R3G280BD13S1 (Centrifugal fan)

Dimensions in mm

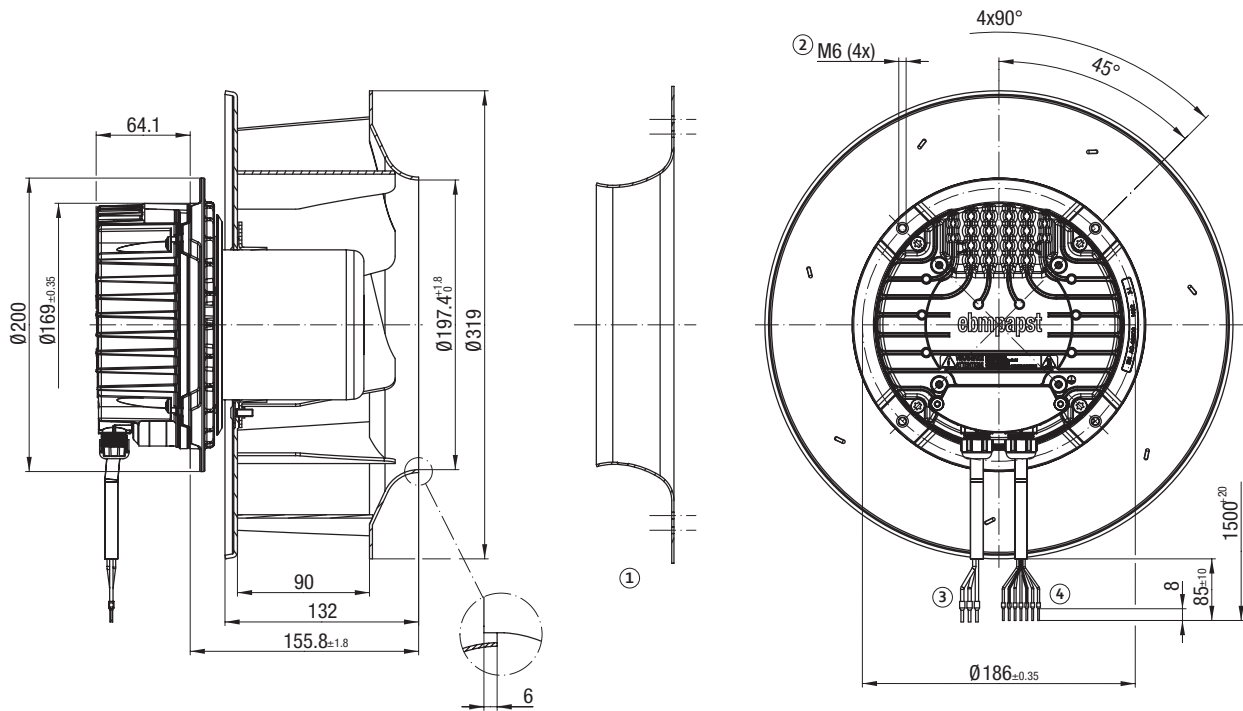

**A** K3G280BD13S1 (Centrifugal fan with support structure)

Dimensions in mm

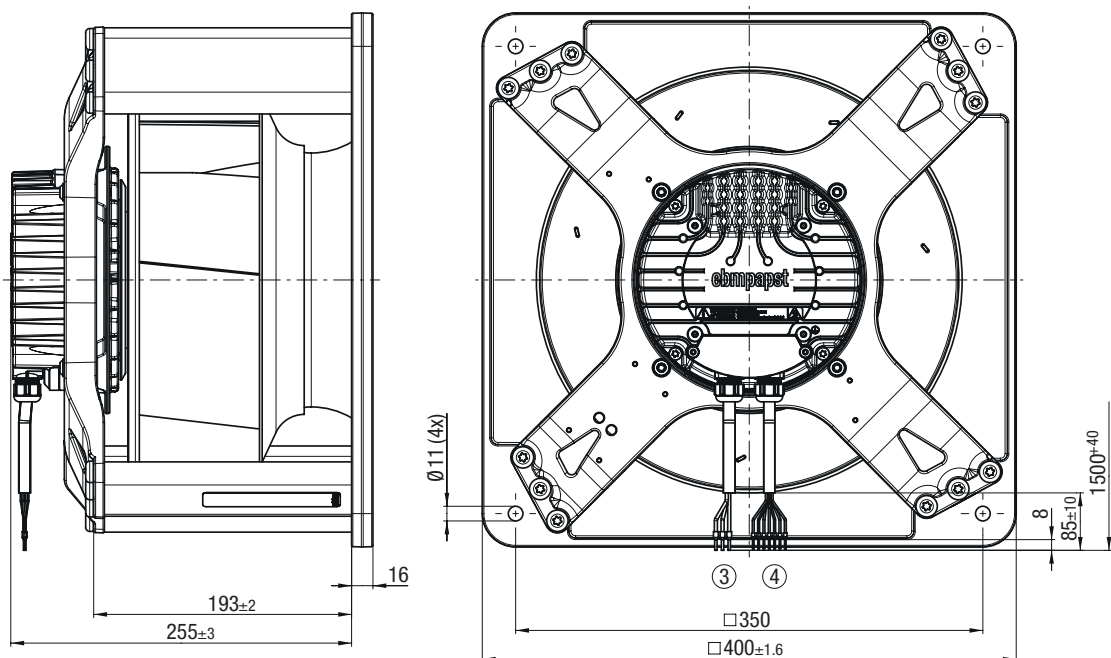

- ① **Accessory part:** Inlet ring 28070-2-4013, not included in scope of delivery  
Dimensions: see "Accessories" chapter
- ② **Max. clearance of screw:** max. 16 mm
- ③ **Cable (halogen-free):** 3x BETAtrans® 3 GW flex, 4G 1.5 mm<sup>2</sup>, 3x crimped ferrules
- ④ **Cable (halogen-free):** 7x BETAtrans® 3 GW flex, 7x 0.5 mm<sup>2</sup>, 7x crimped ferrules

**Pin assignment:** see connection diagram

**Mounting Dimensions for centrifugal modules:**  
see "Accessories" chapter

**B R3G280BC01N1 (Centrifugal fan)**

Dimensions in mm

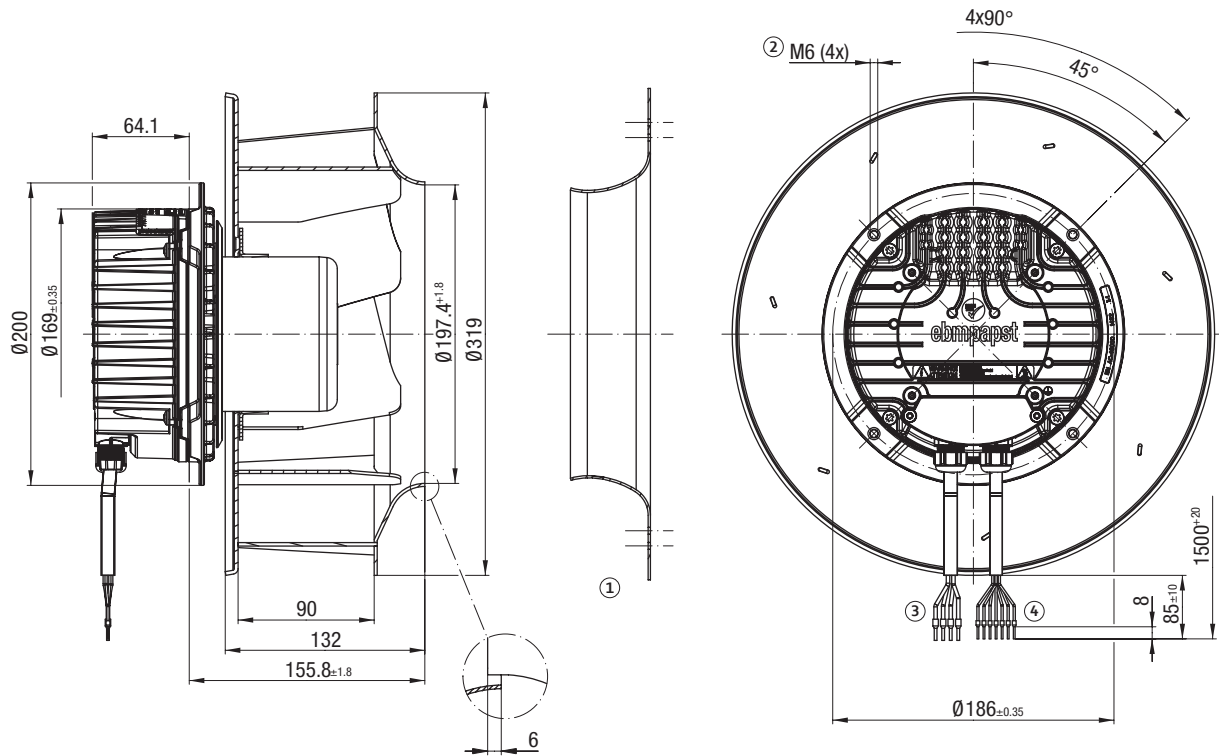

**B K3G280BC01N1 (Centrifugal fan with support structure)**

Dimensions in mm

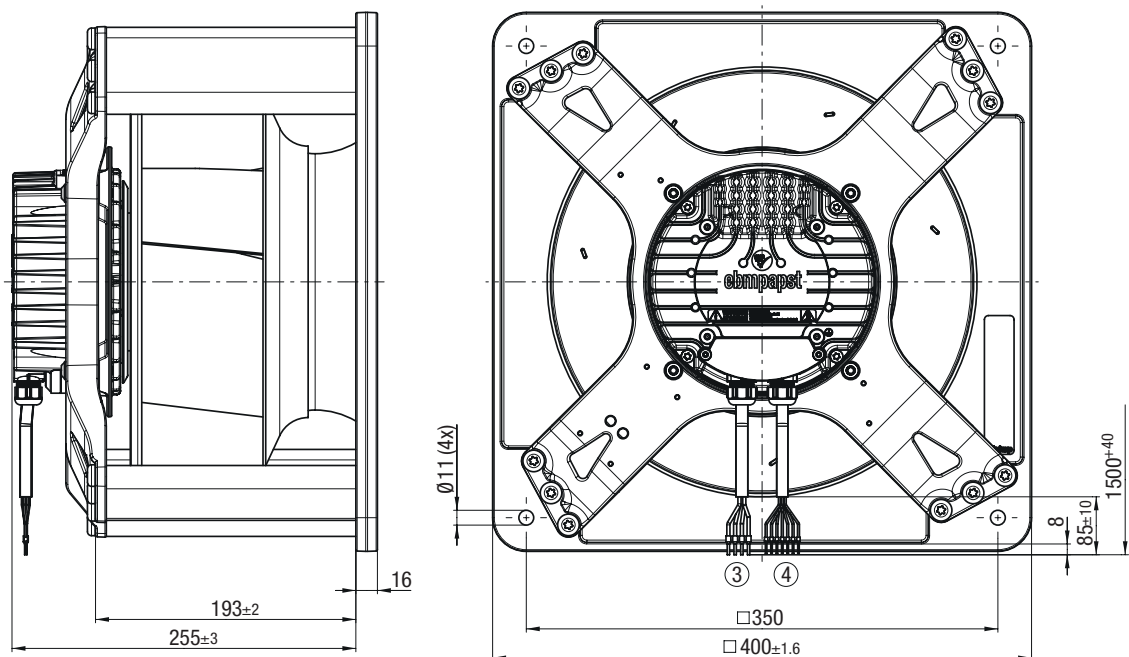

- ① **Accessory part:** Inlet ring 28070-2-4013, not included in scope of delivery  
Dimensions: see "Accessories" chapter
- ② **Max. clearance of screw:** max. 16 mm
- ③ **Cable (halogen-free):** 4x BETAtrans® 3 GKW flex, 4G 1.5 mm<sup>2</sup>, 4x crimped ferrules
- ④ **Cable (halogen-free):** 7x BETAtrans® 3 GKW flex, 7x 0.5 mm<sup>2</sup>, 7x crimped ferrules

**Pin assignment:** see connection diagram

**Mounting Dimensions for centrifugal modules:**  
see "Accessories" chapter



# EC / DC centrifugal fans

backward curved, Ø 310 mm



### Material/surface

- Impeller: PA66 plastic, black
- Rotor: Painted black
- Electronics housing: Die-cast aluminium
- Support structure: Aluminium
- Inlet ring: Sheet steel, galvanized

### Mechanical data

- Direction of rotation: Clockwise viewed toward rotor
- Mode: Continuous operation (S1)
- Mounting: Maintenance-free ball bearings
- Cable exit: lateral

### Standards and approvals

- Conformity with standards: see page 6
- Approvals: EAC

on Page 56	Drawings
on Page 182	Accessories
on Page 192	Connection diagrams and technical features
on Page 204	Technical parameters & scope
More at	<a href="http://www.ebmpapst.com">www.ebmpapst.com</a>

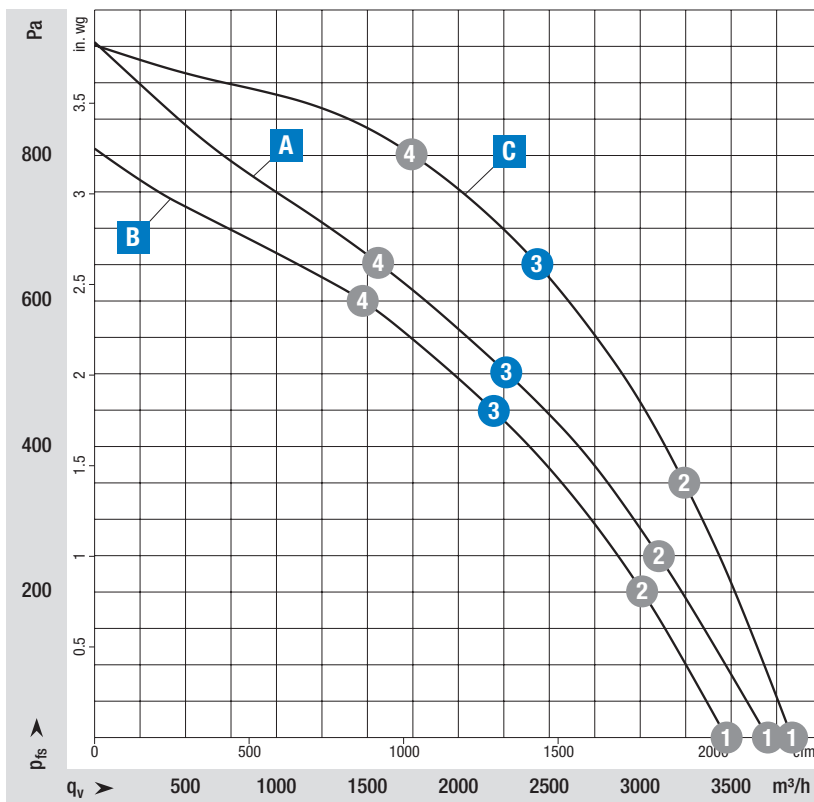

**Measuring requirements**  
 Air performance measured according to: ISO 5801, installation category A, with ebm-papst inlet ring without contact protection.  
 Intake-side sound level: L<sub>pA</sub> according to ISO 13347, L<sub>pA</sub> measured at 1 m distance from fan axis. The values given are only applicable under the specified measuring conditions and may differ depending on the installation conditions. In the event of deviation from the standard configuration, the parameters must be checked in installed condition.

Curve	Operating point	Nominal voltage	Speed n	Max. Input power $P_{ed}$	Max. Input current I	Sound power level L <sub>WA</sub>	Protection class	Installation position	Perm. ambient temp.	Degree of protection	Insulation class	Conn. diagram
		VDC	rpm	W	A	dB(A)						
Voltage range 16-32 V DC												
<b>A</b>	1	24	2550	470	19,5	81	III	Any	-40..+70	Motor: IP 24 KM Electr.: IP 66/69 K	B	BA4)
	2	24	2431	538	22,4	78						
	3	24	<b>2380</b>	<b>581</b>	<b>24,2</b>	<b>74</b>						
	4	24	2402	556	23,1	76						
Voltage range 77-138 V DC												
<b>B</b>	1	110	2355	356	3,24	80	I	Shaft horizontal or rotor on bottom	-40..+60	IP 55 acc. to EN 60529	F	BA6)
	2	110	2290	428	3,99	75						
	3	110	<b>2260</b>	<b>465</b>	<b>4,20</b>	<b>68</b>						
	4	110	2300	450	4,09	72						
Nominal voltage range 380-480 V AC												
<b>C</b>	1	400	2650	538	0,88	83	I	Shaft horizontal or rotor on top	-40..+60	IP 55 acc. to EN 60529	F	BA7)
	2	400	2650	683	1,11	79						
	3	400	<b>2650</b>	<b>750</b>	<b>1,20</b>	<b>75</b>						
	4	400	2650	721	1,17	78						

Values set in blue are nominal data at operating point with maximum load.

Subject to change

Curve	Centrifugal fan		with support structure	
	Part number	Weight kg	Part number	Weight kg
<b>A</b>	R3G310RU2981	3,00	K3G310RU2981	9,40
<b>B</b>	R3G310RR12P1	4,60	K3G310RR12P1	10,50
<b>C</b>	R3G310RR05N1	5,20	K3G310RR05N1	11,10

**A R3G310RU2981 (Centrifugal fan)**

Dimensions in mm

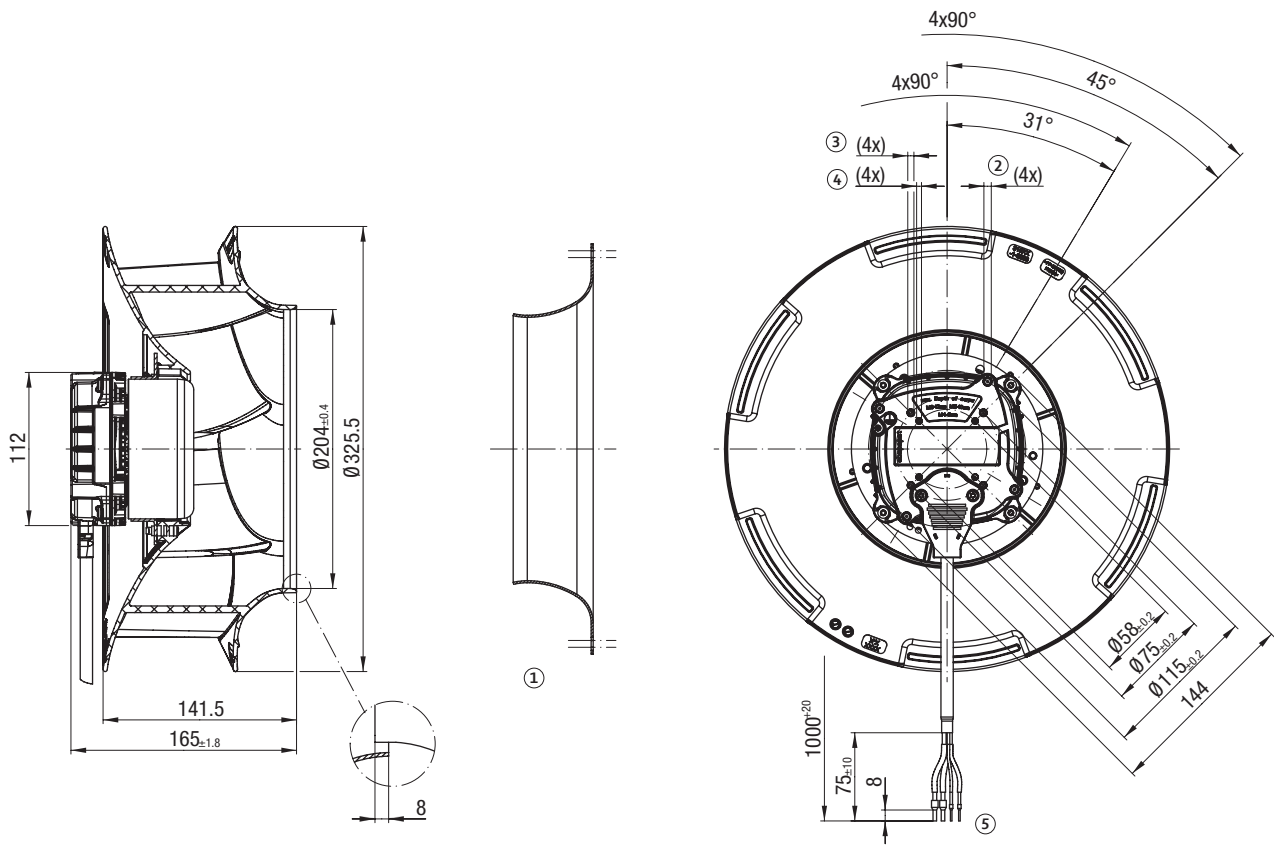

**A K3G310RU2981 (Centrifugal fan with support structure)**

Dimensions in mm

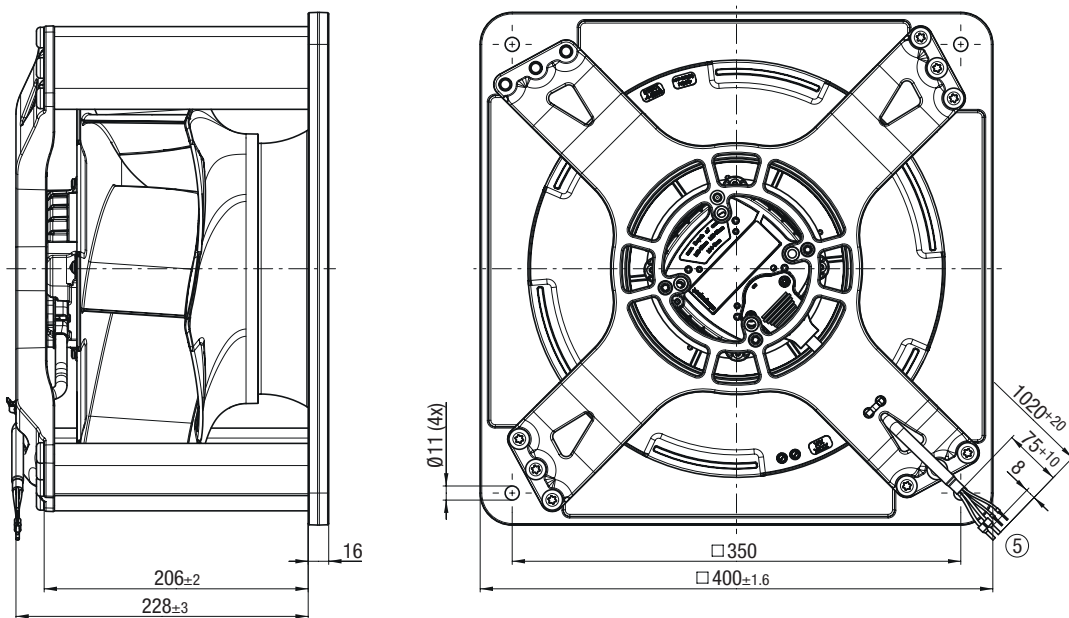

- ① **Accessory part:** Inlet ring 31000-2-4013, not included in scope of delivery  
Dimensions: see "Accessories" chapter
- ② **Max. clearance of screw:** max. 12 mm, tapping hole ready for self-tapping M6 screw
- ③ **Max. clearance of screw:** max. 10 mm, tapping hole ready for self-tapping M5 screw
- ④ **Max. clearance of screw:** max. 8 mm, tapping hole ready for self-tapping M4 screw
- ⑤ **Cable (halogen-free):** 2x BETAtrans® GKW R 2.5 mm<sup>2</sup>, 2x crimped ferrules  
2x BETAtrans® GKW R 1.0 mm<sup>2</sup>, 2x crimped ferrules

Pin assignment: see connection diagram

Mounting Dimensions for centrifugal modules:  
see "Accessories" chapter

**B R3G310RR12P1 (Centrifugal fan)**

Dimensions in mm

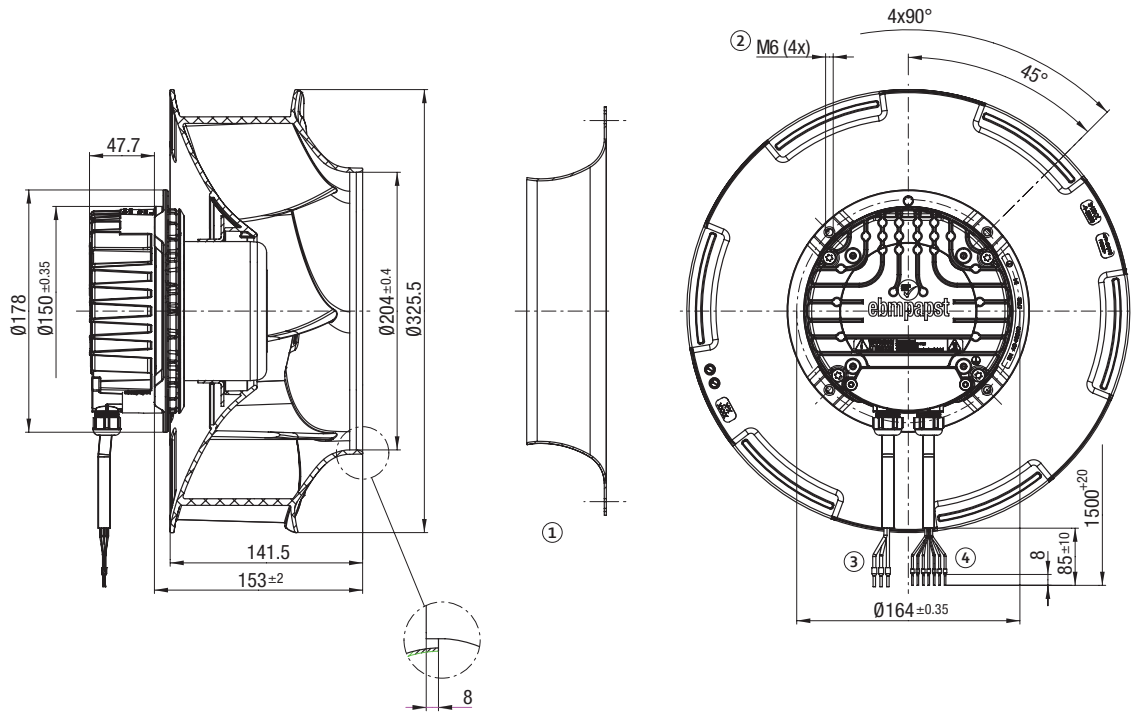

**B K3G310RR12P1 (Centrifugal fan with support structure)**

Dimensions in mm

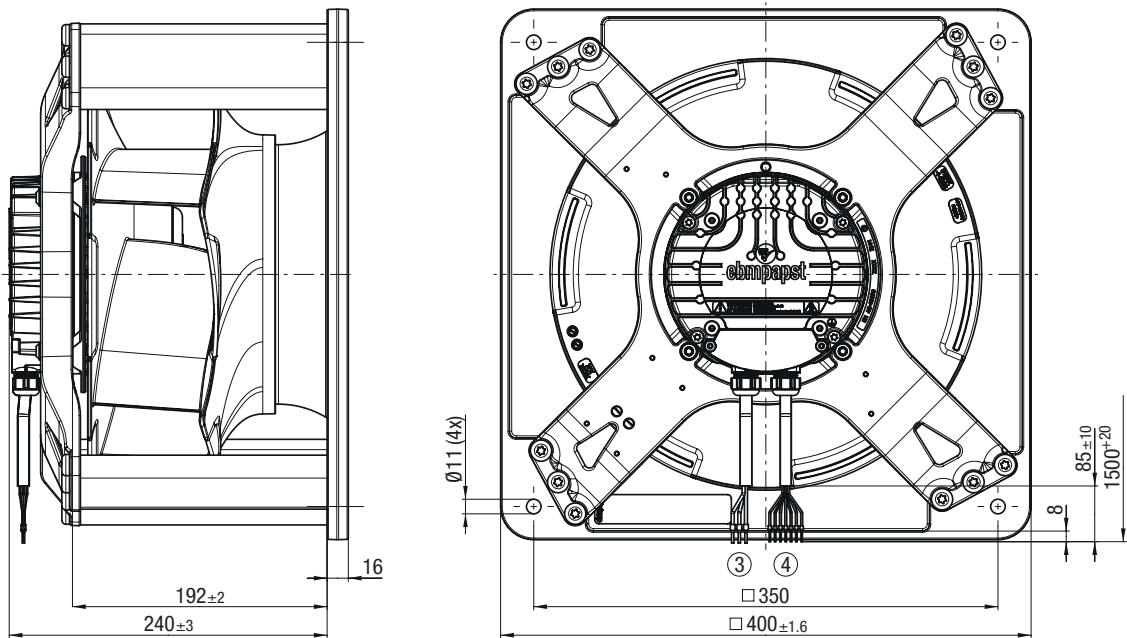

- ① **Accessory part:** Inlet ring 31000-2-4013, not included in scope of delivery  
Dimensions: see "Accessories" chapter
- ② **Max. clearance of screw:** max. 16 mm
- ③ **Cable (halogen-free):** 3x BETAtrans® 3 GKW flex, 4G 1.5 mm<sup>2</sup>, 3x crimped ferrules
- ④ **Cable (halogen-free):** 7x BETAtrans® 3 GKW flex, 7x 0.5 mm<sup>2</sup>, 7x crimped ferrules

**Pin assignment:** see connection diagram

**Mounting Dimensions for centrifugal modules:**  
see "Accessories" chapter

**C R3G310RR05N1 (Centrifugal fan)**

Dimensions in mm

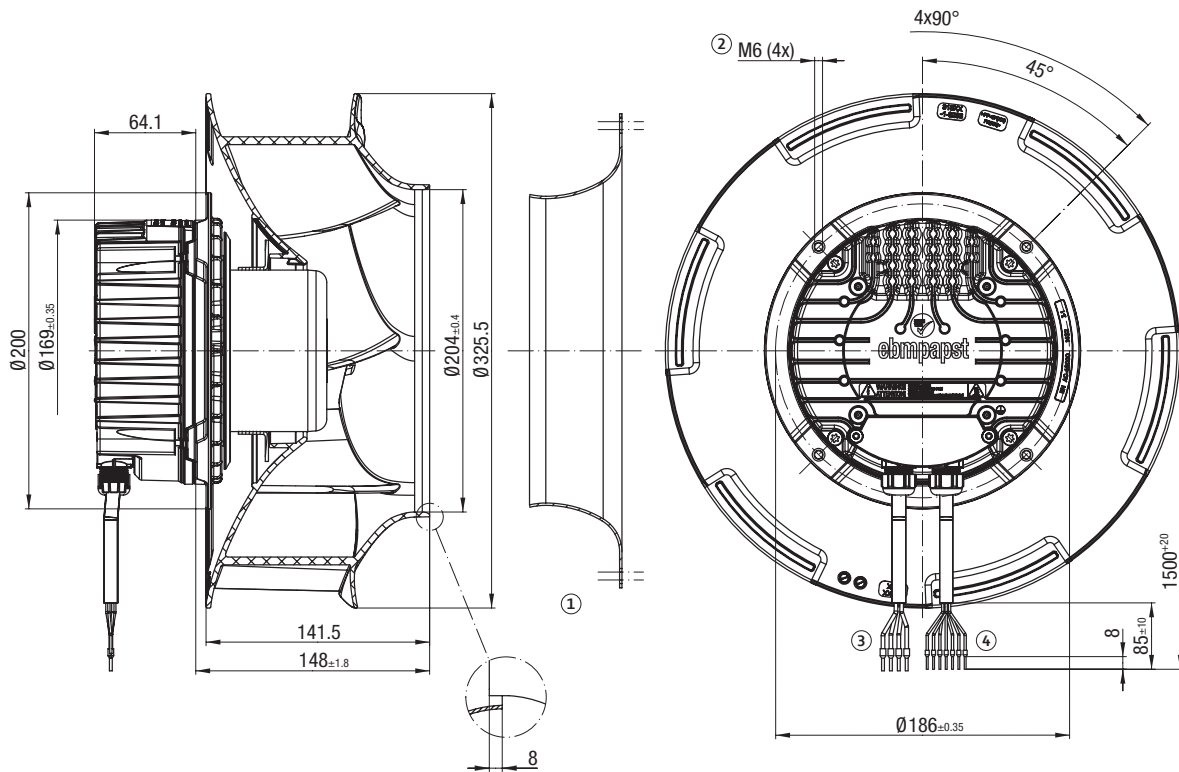

**C K3G310RR05N1 (Centrifugal fan with support structure)**

Dimensions in mm

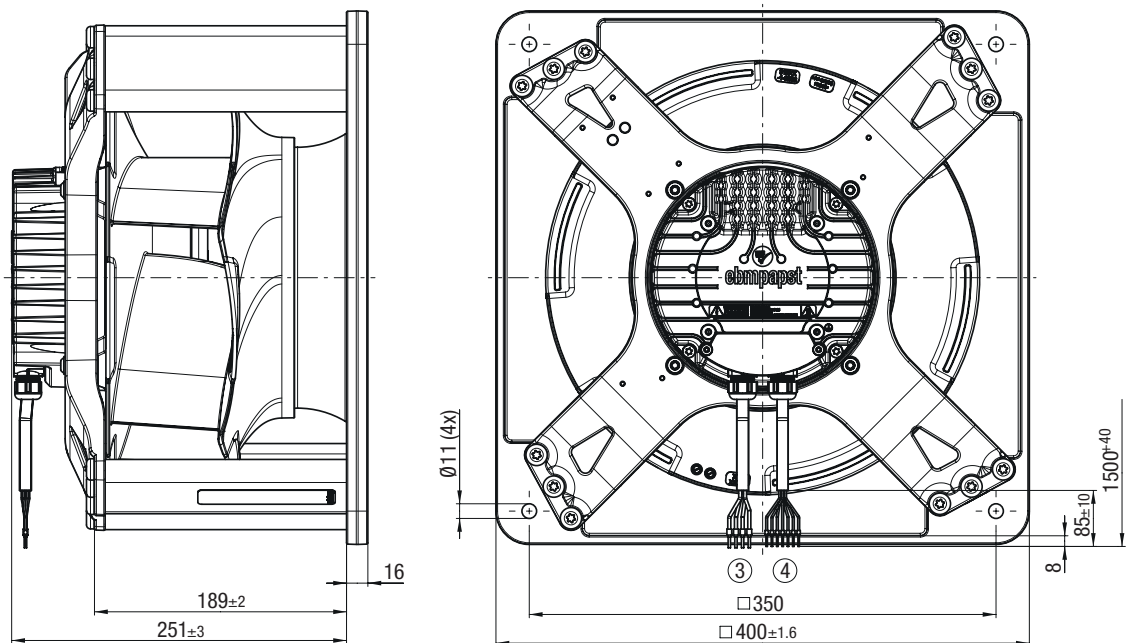

- ① **Accessory part:** Inlet ring 31000-2-4013, not included in scope of delivery  
Dimensions: see "Accessories" chapter
- ② **Max. clearance of screw:** max. 16 mm
- ③ **Cable (halogen-free):** 4x BETAtrans® 3 GKW flex, 4G 1.5 mm<sup>2</sup>, 4x crimped ferrules
- ④ **Cable (halogen-free):** 7x BETAtrans® 3 GKW flex, 7x 0.5 mm<sup>2</sup>, 7x crimped ferrules

**Pin assignment:** see connection diagram

**Mounting Dimensions for centrifugal modules:** see "Accessories" chapter



# EC / DC centrifugal fans

backward curved, Ø 310 mm, Aluminium impeller

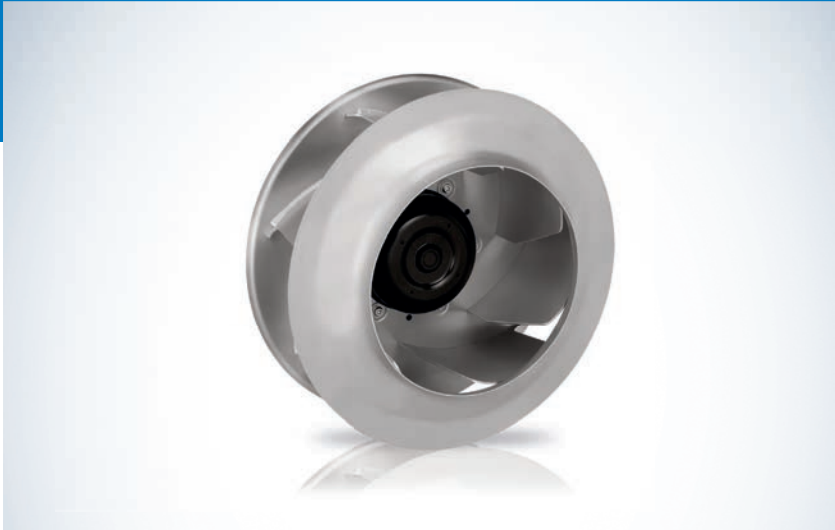

### Material/surface

- Impeller: Sheet aluminium
- Rotor: Painted black
- Electronics housing: Die-cast aluminium
- Support structure: Aluminium
- Inlet ring: Sheet steel, galvanized

### Mechanical data

- Direction of rotation: Clockwise viewed toward rotor
- Mode: Continuous operation (S1)
- Mounting: Maintenance-free ball bearings
- Cable exit: lateral

### Standards and approvals

- Conformity with standards: see page 6
- Approvals: EAC

on Page 62	Drawings
on Page 182	Accessories
on Page 192	Connection diagrams and technical features
on Page 204	Technical parameters & scope
More at	<a href="http://www.ebmpapst.com">www.ebmpapst.com</a>

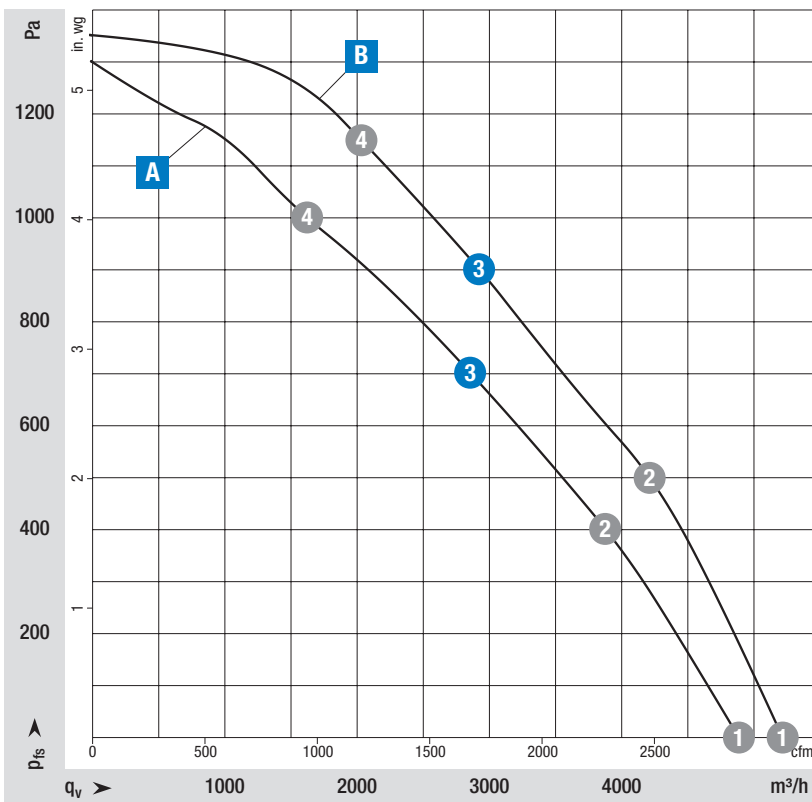

#### Measuring requirements

Air performance measured according to: ISO 5801, installation category A, with ebmpapst inlet ring without contact protection.  
 Intake-side sound level:  $L_{pA}$  according to ISO 13347,  $L_{pA}$  measured at 1 m distance from fan axis. The values given are only applicable under the specified measuring conditions and may differ depending on the installation conditions. In the event of deviation from the standard configuration, the parameters must be checked in installed condition.



Curve	Operating point	Nominal voltage	Speed n	Max. Input power P <sub>ed</sub>	Max. Input current I	Sound power level L <sub>WA</sub>	Protection class	Installation position	Perm. ambient temp.	Degree of protection	Insulation class	Conn. diagram
		VDC	rpm	W	A	dB(A)						
Voltage range 77-138 V DC												
<b>A</b>	①	110	2915	995	9,00	88	I	Shaft horizontal or rotor on bottom	-40..+60	IP 55 acc. to EN 60529	F	BA6)
	②	110	2730	995	9,00	82						
	③	110	2650	995	9,00	77						
	④	110	2765	995	9,00	84						
Nominal voltage range 380-480 V AC												
<b>B</b>	①	400	3135	1229	1,89	90	I	Shaft horizontal or rotor on bottom	-40..+60	IP 55 acc. to EN 60529	F	BA7)
	②	400	3005	1300	2,00	85						
	③	400	2900	1300	2,00	80						
	④	400	2970	1300	2,00	85						

Values set in blue are nominal data at operating point with maximum load.

Subject to change

Curve	Centrifugal fan		with support structure	
	Part number	Weight kg	Part number	Weight kg
<b>A</b>	R3G310BE84S1	8,50	K3G310BE84S1	15,0
<b>B</b>	R3G310BE90N1	8,50	K3G310BE90N1	15,0

**A R3G310BE84S1 (Centrifugal fan)**

Dimensions in mm

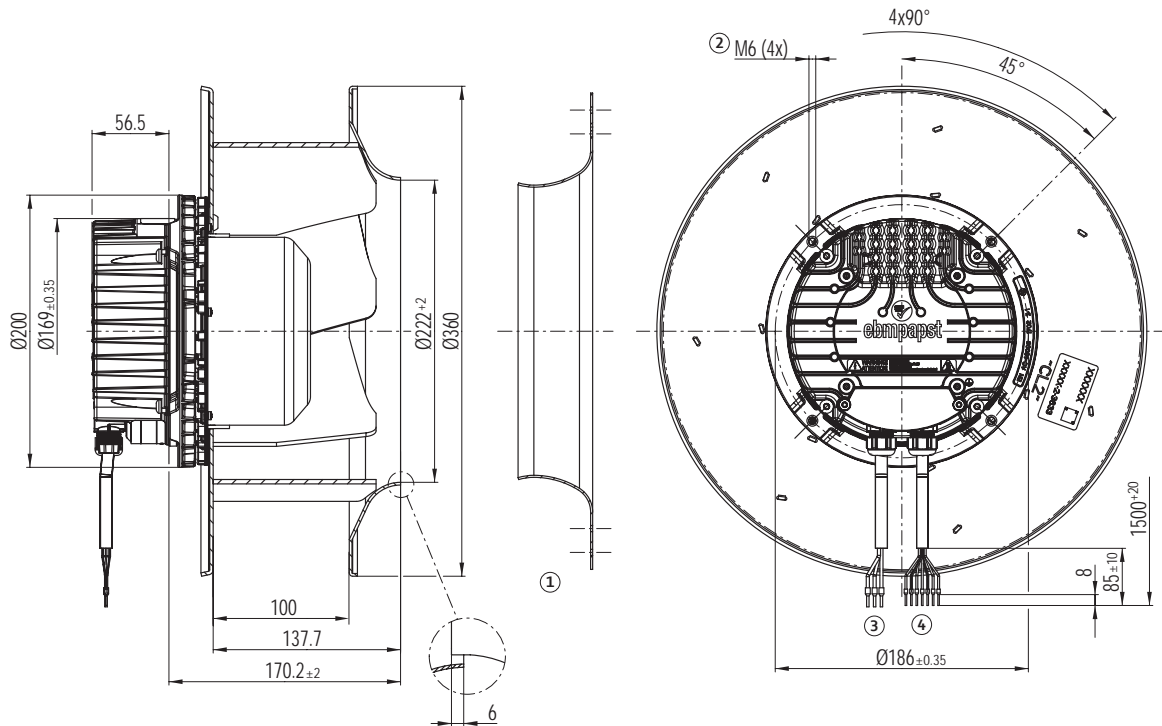

**A K3G310BE84S1 (Centrifugal fan with support structure)**

Dimensions in mm

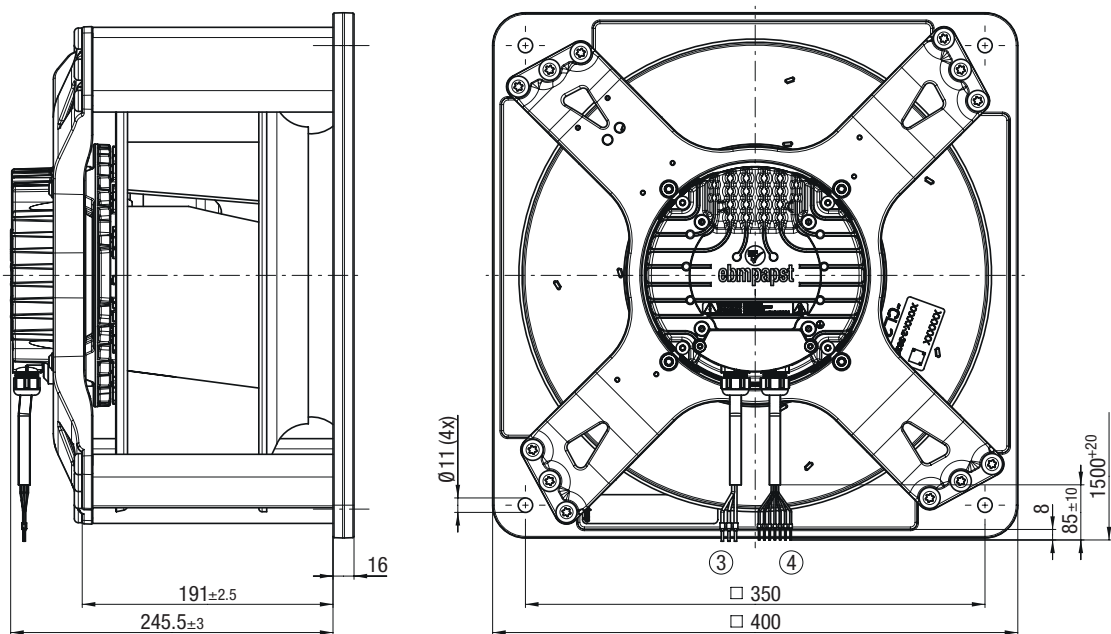

- ① **Accessory part:** Inlet ring 31570-2-4013, not included in scope of delivery  
Dimensions: see "Accessories" chapter
- ② **Max. clearance of screw:** max. 16 mm
- ③ **Cable (halogen-free):** 3x BETAtans<sup>®</sup> 3 GKW flex, 4G 1.5 mm<sup>2</sup>, 3x crimped ferrules
- ④ **Cable (halogen-free):** 7x BETAtans<sup>®</sup> 3 GKW flex, 7x 0.5 mm<sup>2</sup>, 7x crimped ferrules

**Pin assignment:** see connection diagram

**Mounting Dimensions for centrifugal modules:**  
see "Accessories" chapter

**B R3G310BE90N1 (Centrifugal fan)**

Dimensions in mm

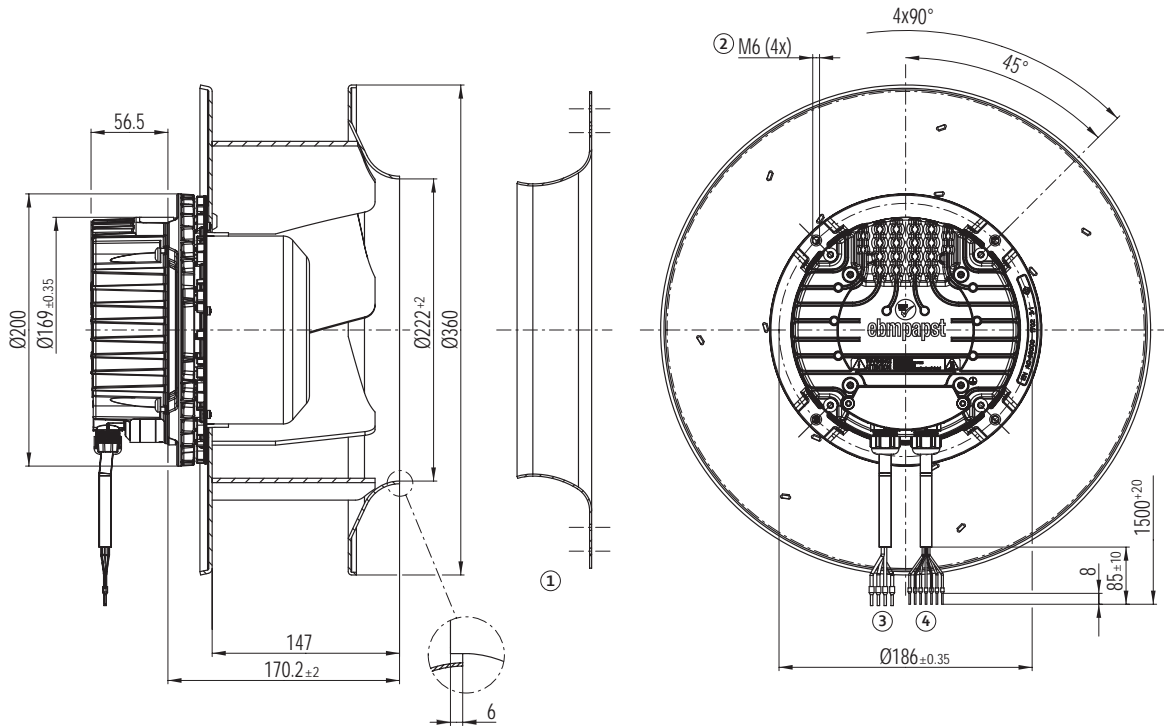

**B K3G310BE90N1 (Centrifugal fan with support structure)**

Dimensions in mm

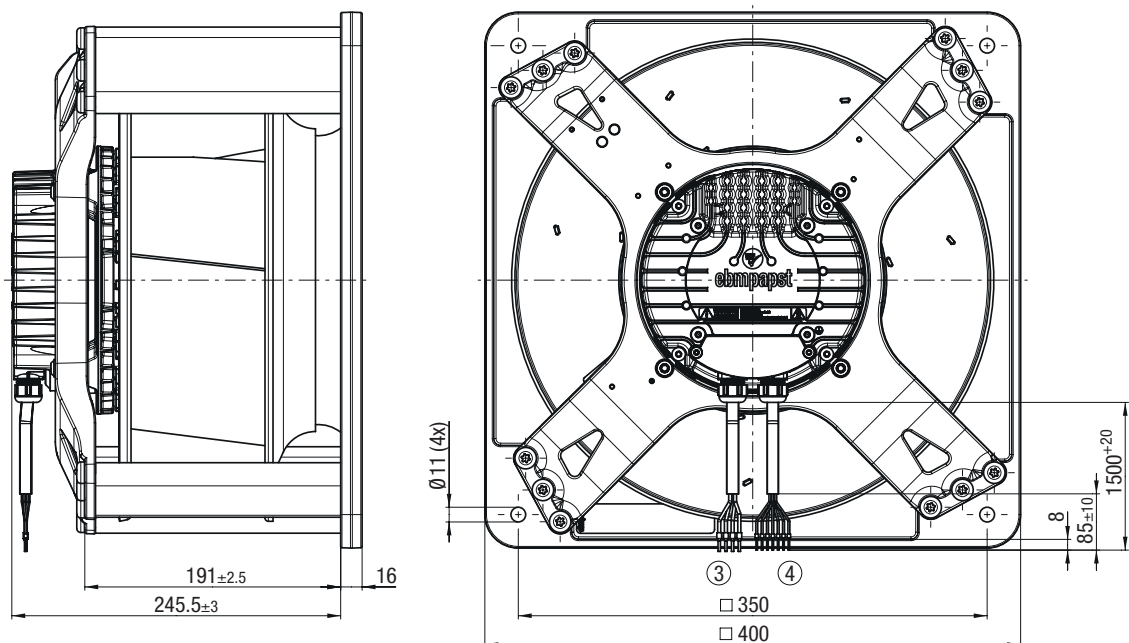

- ① **Accessory part:** Inlet ring 31570-2-4013, not included in scope of delivery  
Dimensions: see "Accessories" chapter
- ② **Max. clearance of screw:** max. 16 mm
- ③ **Cable (halogen-free):** 4x BETAtrans® 3 GKW flex, 4G 1.5 mm<sup>2</sup>, 4x crimped ferrules
- ④ **Cable (halogen-free):** 7x BETAtrans® 3 GKW flex, 7x 0.5 mm<sup>2</sup>, 7x crimped ferrules

**Pin assignment:** see connection diagram

**Mounting Dimensions for centrifugal modules:**  
see "Accessories" chapter

# EC / DC centrifugal fans

backward curved, Ø 355 mm



### Material/surface

- Impeller: PA66 plastic, black
- Rotor: Painted black
- Electronics housing: Die-cast aluminium

### Mechanical data

- Direction of rotation: Clockwise viewed toward rotor
- Mode: Continuous operation (S1)
- Mounting: Maintenance-free ball bearings
- Cable exit: lateral

### Standards and approvals

- Conformity with standards: see page 6
- Approvals: EAC

on Page 66	Drawings
on Page 182	Accessories
on Page 192	Connection diagrams and technical features
on Page 204	Technical parameters & scope
More at	<a href="http://www.ebmpapst.com">www.ebmpapst.com</a>

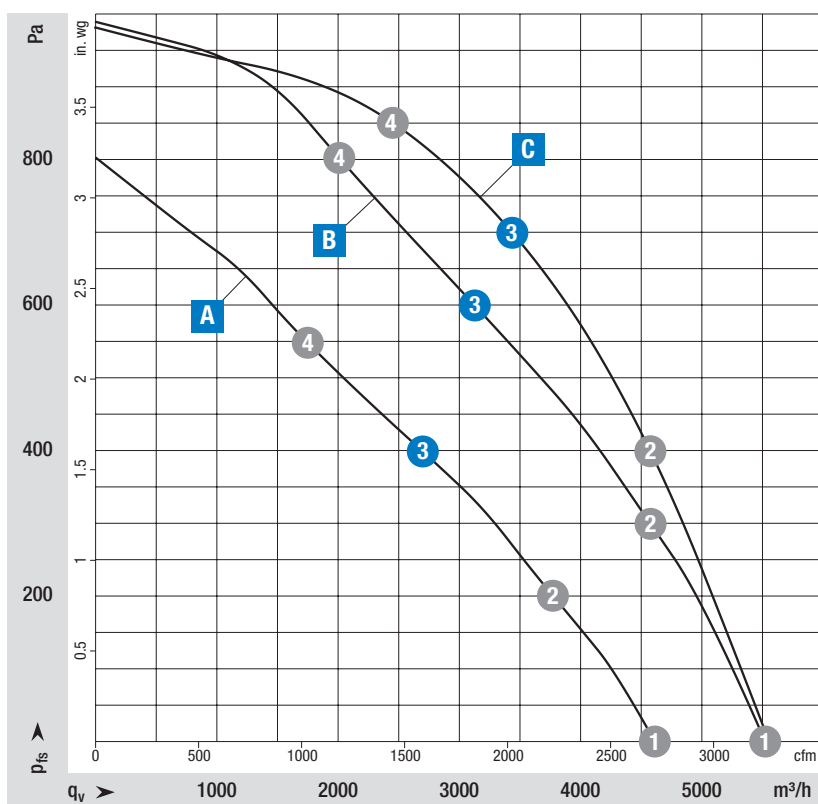

#### Measuring requirements

Air performance measured according to: ISO 5801, installation category A, with ebmpapst inlet ring without contact protection.  
 Intake-side sound level:  $L_{pA}$  according to ISO 13347,  $L_{pA}$  measured at 1 m distance from fan axis. The values given are only applicable under the specified measuring conditions and may differ depending on the installation conditions. In the event of deviation from the standard configuration, the parameters must be checked in installed condition.

Curve	Operating point	Nominal voltage	Speed n	Max. Input power P <sub>ed</sub>	Max. Input current I	Sound power level L <sub>WA</sub>	Protection class	Installation position	Perm. ambient temp.	Degree of protection	Insulation class	Conn. diagram
		VDC	rpm	W	A	dB(A)			°C			
Voltage range 77-138 V DC												
<b>A</b>	1	110	2035	475	4,32	81	I	Shaft horizontal or rotor on bottom	-40..+60	IP 55 acc. to EN 60529	F	BA6)
	2	110	1905	500	4,70	76						
	3	<b>110</b>	<b>1830</b>	<b>500</b>	<b>4,70</b>	<b>70</b>						
	4	110	1885	500	4,70	74						
<b>B</b>	1	110	2400	759	6,89	93	I	Shaft horizontal or rotor on bottom	-40..+60	IP 55 acc. to EN 60529	F	BA6)
	2	110	2285	880	8,00	85						
	3	<b>110</b>	<b>2200</b>	<b>880</b>	<b>8,00</b>	<b>75</b>						
	4	110	2270	880	8,00	78						
Nominal voltage range 380-480 V AC												
<b>C</b>	1	400	2400	777	1,20	90	I	Shaft horizontal or rotor on bottom	-40..+60	IP 55 acc. to EN 60529	F	BA7)
	2	400	2400	1037	1,59	83						
	3	<b>400</b>	<b>2400</b>	<b>1100</b>	<b>1,70</b>	<b>75</b>						
	4	400	2400	1056	1,62	77						

Values set in blue are nominal data at operating point with maximum load.

Subject to change

Curve		
	Centrifugal fan	
	Part number	Weight
		kg
<b>A</b>	R3G355RS13P1	5,50
<b>B</b>	R3G355RJ85S1	8,40
<b>C</b>	R3G333RJ76N1	8,40

**A R3G355RS13P1 (Centrifugal fan)**

Dimensions in mm

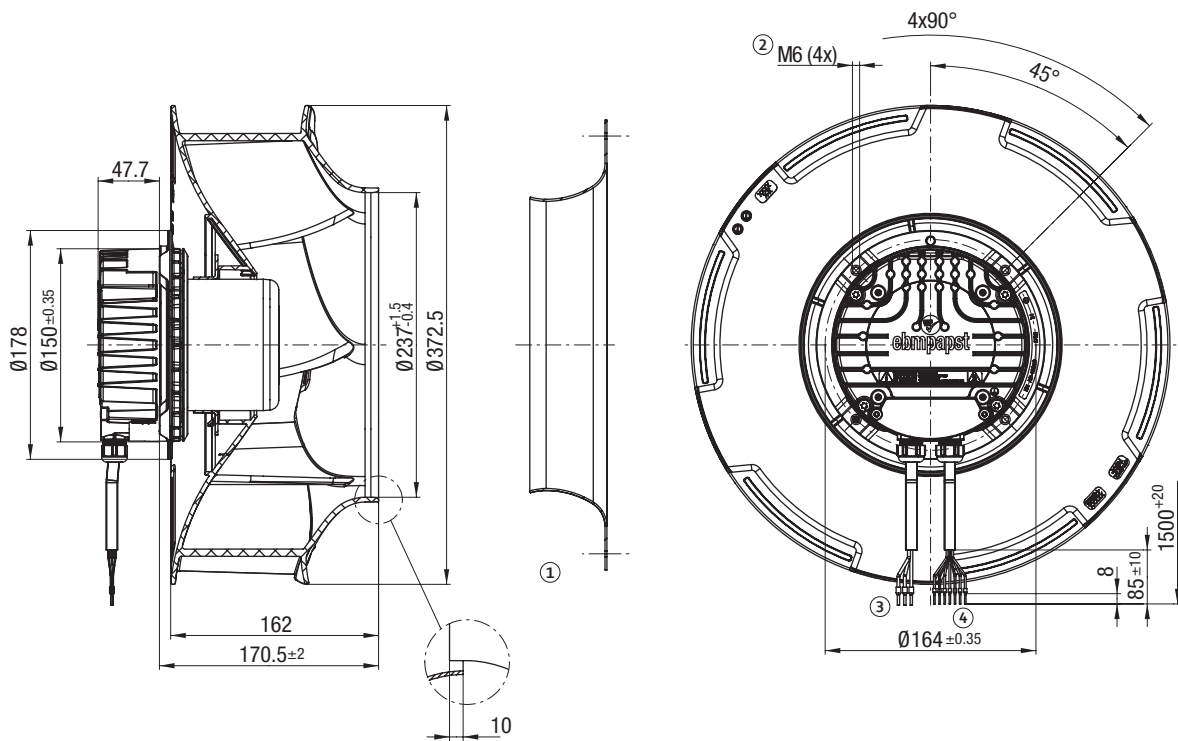

- ① **Accessory part:** Inlet ring 35500-2-4013, not included in scope of delivery  
Dimensions: see "Accessories" chapter
- ② **Max. clearance of screw:** max. 16 mm
- ③ **Cable (halogen-free):** 3x BETrans<sup>®</sup> 3 GKW flex, 4G 1.5 mm<sup>2</sup>, 3x crimped ferrules
- ④ **Cable (halogen-free):** 7x BETrans<sup>®</sup> 3 GKW flex, 7x 0.5 mm<sup>2</sup>, 7x crimped ferrules

Pin assignment: see connection diagram

**B K3G355RJ85S1 (Centrifugal fan)**

Dimensions in mm

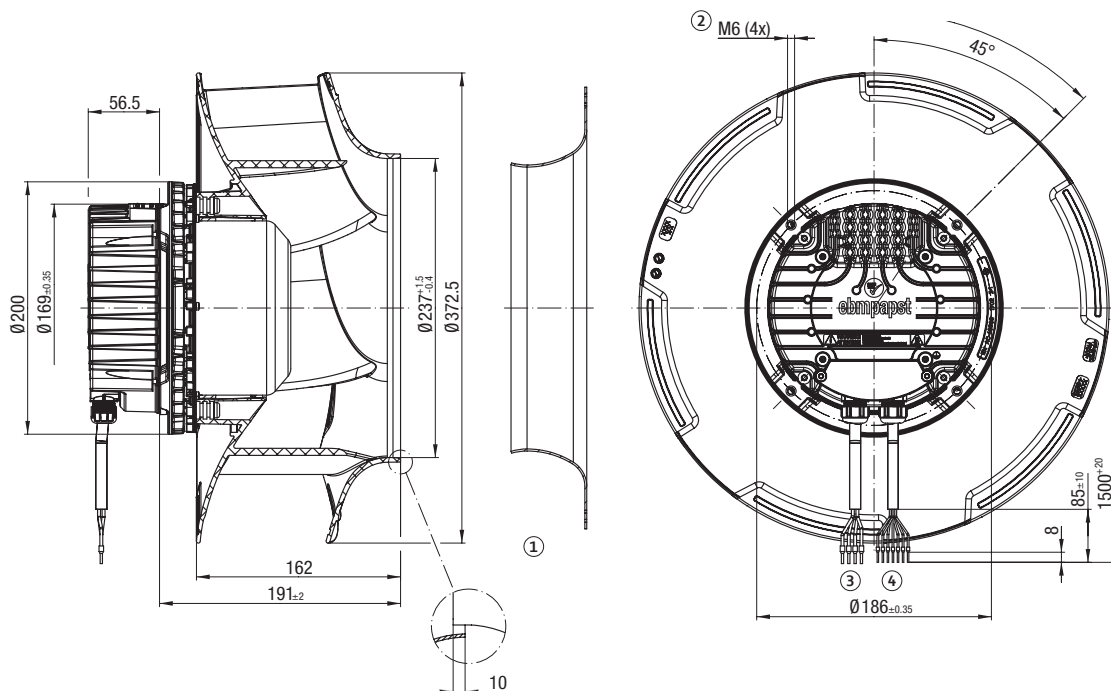

- ① **Accessory part:** Inlet ring 35500-2-4013, not included in scope of delivery  
Dimensions: see "Accessories" chapter
- ② **Max. clearance of screw:** max. 16 mm
- ③ **Cable (halogen-free):** 3x BETrans<sup>®</sup> 3 GKW flex, 4G 1.5 mm<sup>2</sup>, 3x crimped ferrules
- ④ **Cable (halogen-free):** 7x BETrans<sup>®</sup> 3 GKW flex, 7x 0.5 mm<sup>2</sup>, 7x crimped ferrules

Pin assignment: see connection diagram

## C R3G355RJ76N1 (Centrifugal fan)

Dimensions in mm

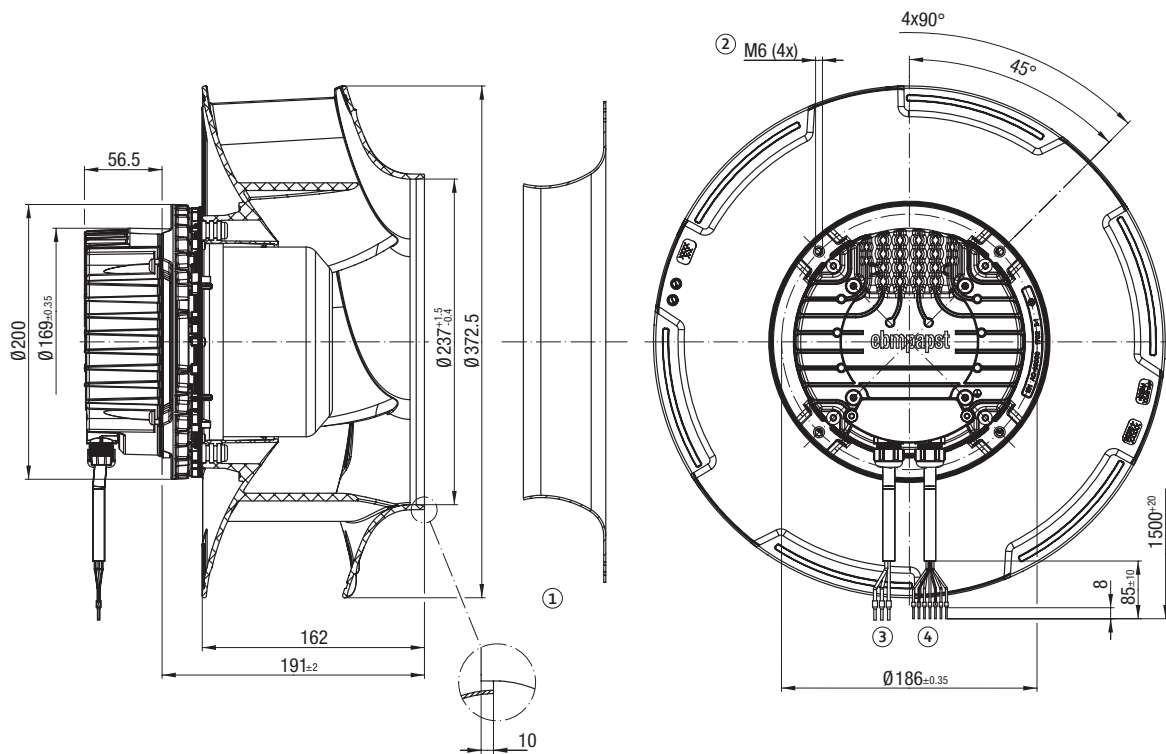

- ① **Accessory part:** Inlet ring 35500-2-4013, not included in scope of delivery  
Dimensions: see "Accessories" chapter
- ② **Max. clearance of screw:** max. 16 mm
- ③ **Cable (halogen-free):** 4x BETAtrans<sup>®</sup> 3 GKW flex, 4G 1.5 mm<sup>2</sup>, 4x crimped ferrules
- ④ **Cable (halogen-free):** 7x BETAtrans<sup>®</sup> 3 GKW flex, 7x 0.5 mm<sup>2</sup>, 7x crimped ferrules

Pin assignment: see connection diagram

# EC / DC centrifugal fans

backward curved, Ø 400 mm, Aluminium impeller

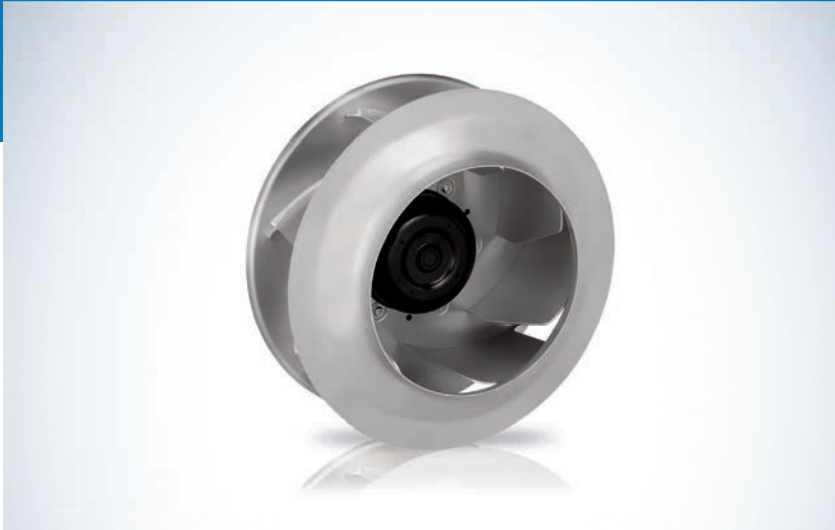

### Material/surface

- Impeller: Sheet aluminium
- Rotor: Painted black
- Electronics housing: Die-cast aluminium

### Mechanical data

- Direction of rotation: Clockwise viewed toward rotor
- Mode: Continuous operation (S1)
- Mounting: Maintenance-free ball bearings
- Cable exit: lateral

### Standards and approvals

- Conformity with standards: see page 6
- Approvals: EAC

on Page 70	Drawings
on Page 182	Accessories
on Page 192	Connection diagrams and technical features
on Page 204	Technical parameters & scope
More at	<a href="http://www.ebmpapst.com">www.ebmpapst.com</a>

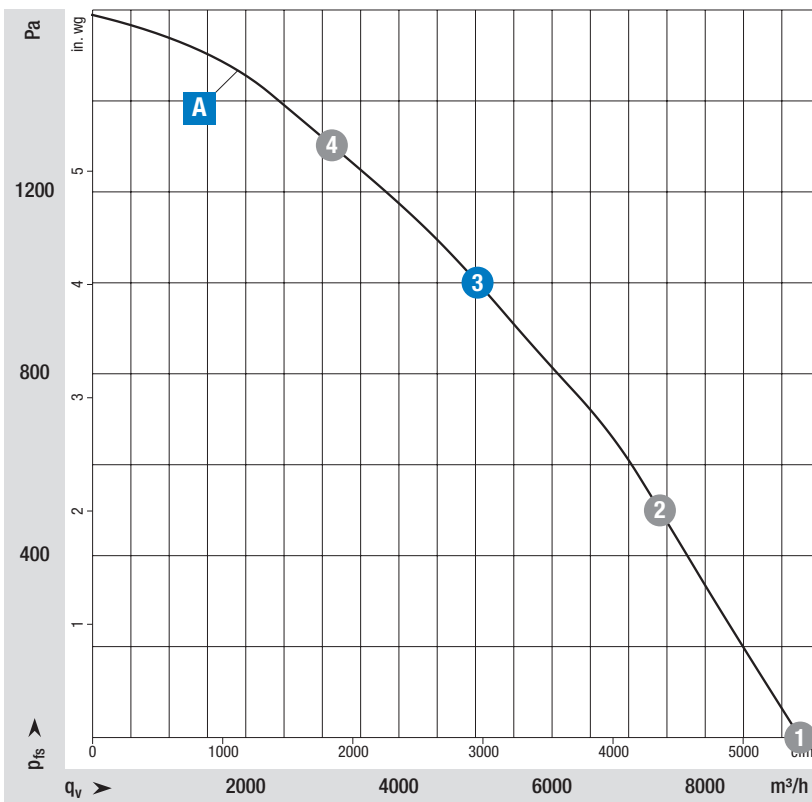

#### Measuring requirements

Air performance measured according to: ISO 5801, installation category A, with ebm-papst inlet ring without contact protection.  
 Intake-side sound level:  $L_{wA}$  according to ISO 13347,  $L_{pA}$  measured at 1 m distance from fan axis. The values given are only applicable under the specified measuring conditions and may differ depending on the installation conditions. In the event of deviation from the standard configuration, the parameters must be checked in installed condition.



Curve	Operating point	Nominal voltage	Speed n	Max. Input power $P_{ed}$	Max. Input current I	Sound power level $L_{wA}$	Protection class	Installation position	Perm. ambient temp.	Degree of protection	Insulation class	Conn. diagram
		VDC	rpm	W	A	dB(A)			°C			
Nominal voltage range 380-480 V AC												
A	1	400	2600	2400	3,70	95	I	Shaft horizontal or rotor on bottom	-40..+60	IP 55	F	BA8)
	2	400	2430	2400	3,70	89						
	3	400	2400	2400	3,70	84						
	4	400	2505	2372	3,67	88						

Values set in blue are nominal data at operating point with maximum load.

Subject to change

Curve		
	Centrifugal fan	
	Part number	Weight
A	R3G400BE08N1	15,10 kg

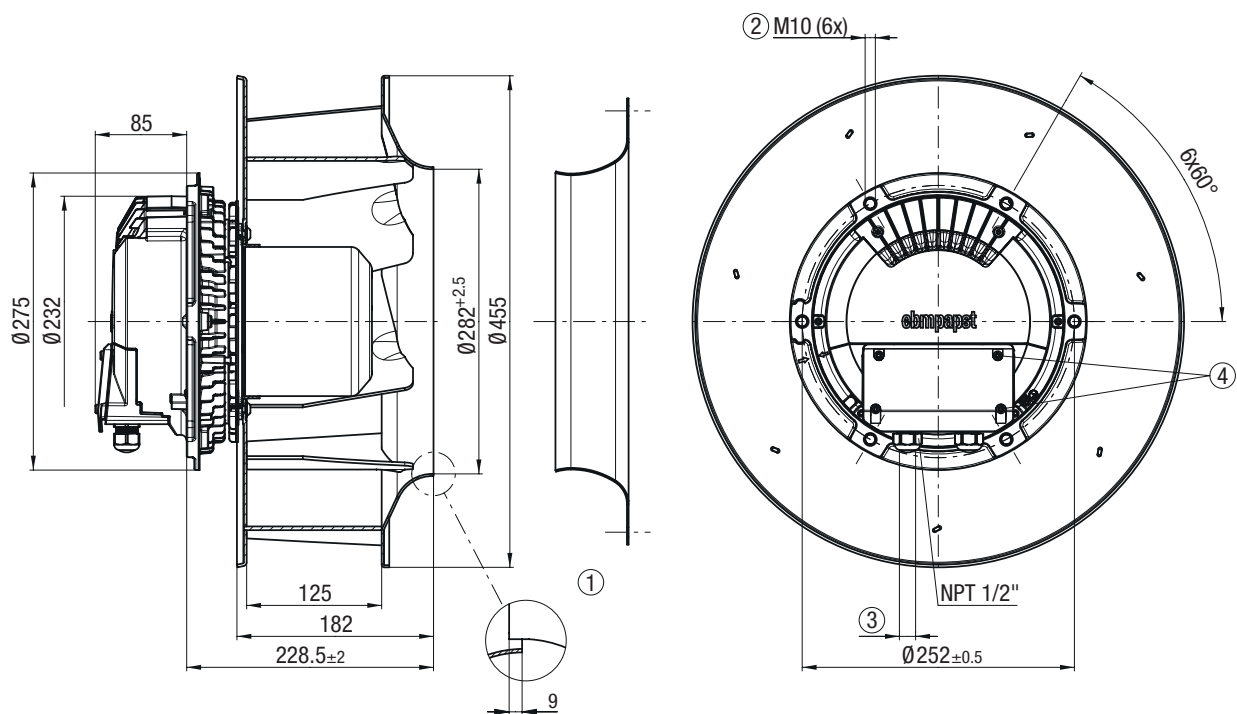

- ① **Accessory part:** Inlet ring 40070-2-4013, not included in scope of delivery  
Dimensions: see "Accessories" chapter
- ② **Max. clearance of screw:** max. 20 mm
- ③ **Cable diameter:** min. 4 mm, max. 10 mm, Tightening torque  $2 \pm 0.3$  Nm
- ④ **Tightening torque:**  $1.5 \pm 0.2$  Nm

Pin assignment: see connection diagram





# EC / DC axial fans Ø 300 - Ø 500

**ebmpapst**

the engineer's choice

	Page
Ø 300-385	74
Ø 300-350 HyBlade	78
Ø 400 HyBlade	82
Ø 450 HyBlade	86
Ø 500 HyBlade	90

# EC / DC axial fans

Ø 300-385 mm



## Material/surface

- Housing and Impeller: PA66 plastic, black

## Mechanical data

- Direction of rotation: Clockwise viewed toward rotor
- Direction of air flow: "V" (sucking over rotor)
- Mode: Continuous operation (S1)
- Mounting: Maintenance-free ball bearings
- Cable exit: lateral

## Standards and approvals

- Conformity with standards: see page 6
- Approvals: EAC

on Page 76	Drawings
on Page 192	Connection diagrams and technical features
on Page 204	Technical parameters & scope
More at	<a href="http://www.ebmpapst.com">www.ebmpapst.com</a>

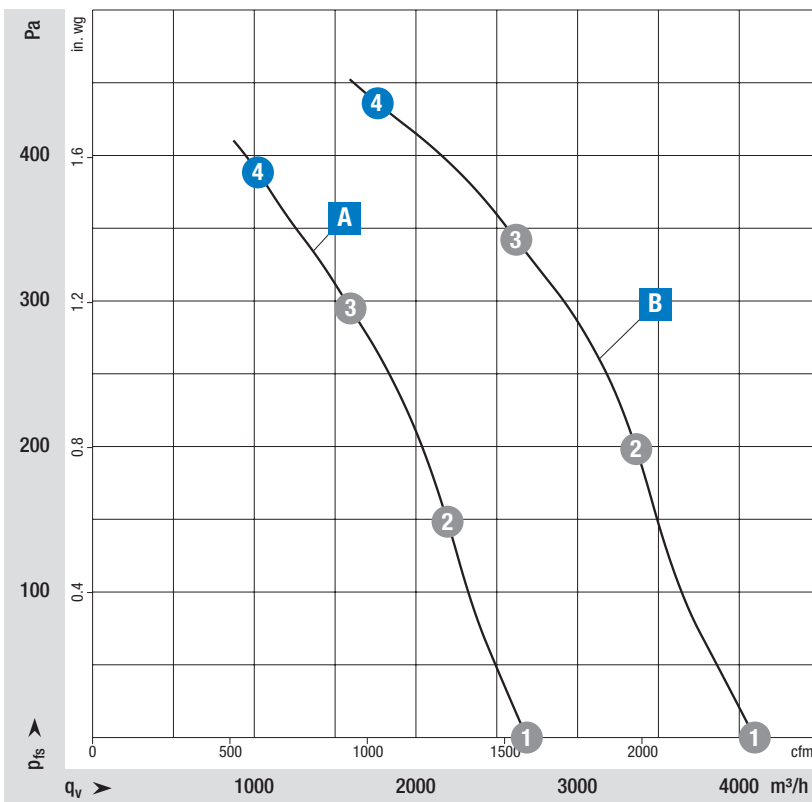

### Measuring requirements

Air performance measured according to: ISO 5801, installation category A, without contact protection.  
 Intake-side sound level:  $L_{pA}$  according to ISO 13347,  $L_{pA}$  measured at 1 m distance from fan axis. The values given are only applicable under the specified measuring conditions and may differ depending on the installation conditions. In the event of deviation from the standard configuration, the parameters must be checked in installed condition.

Curve	Operating point	Nominal voltage		Speed n	Max. Input power P <sub>ed</sub>	Max. Input current I	Sound power level L <sub>WA</sub>	Protection class	Installation position	Perm. ambient temp.	Degree of protection	Insulation class	Conn. diagram
		VDC	rpm										
Voltage range 16-32 V DC													
<b>A</b>	1	24	3350	230	9,00	83	III	Any	-40..+85	Motor: IP 24 KM Electr.: IP 66/69 K	B	BA3)	
	2	24	3350	277	10,7	84							
	3	24	3350	341	13,1	84							
	4	24	<b>3350</b>	<b>379</b>	<b>14,6</b>	<b>87</b>							
<b>B</b>	1	24	3140	450	17,7	88	III	Any	-40..+70	Motor: IP 24 KM Electr.: IP 66/69 K	B	BA4)	
	2	24	3126	562	22,6	88							
	3	24	3059	622	25,2	88							
	4	24	<b>2959</b>	<b>649</b>	<b>26,3</b>	<b>89</b>							

Values set in blue are nominal data at operating point with maximum load.

Subject to change

Curve		
	Axial fan	
	Part number	Weight
		kg
<b>A</b>	W3G300BV2582	2,00
<b>B</b>	W3G385CT6581	3,10

**A** W3G300BV2582 (Axial fan)

Dimensions in mm

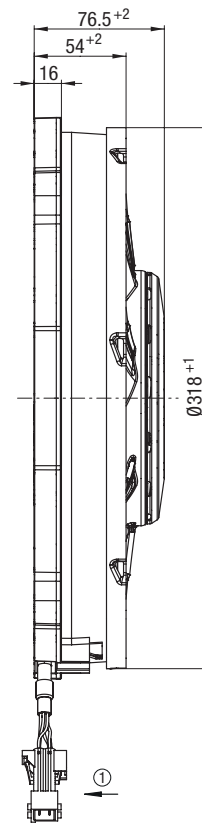
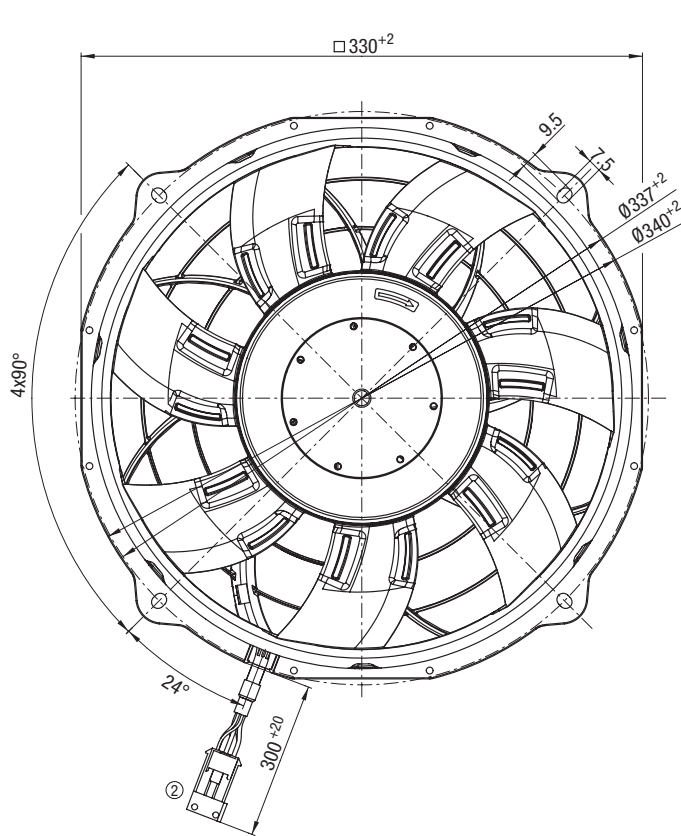

- ① Direction of air flow: "V"
- ② Cable: with plug tyco Junior Power Timer 1-962349-1, 6-pole, coded  
Mating plug tyco 1-962312-1 not included in scope of delivery

Pin assignment: see connection diagram



**B** W3G385CT6581 (Axial fan)

Dimensions in mm

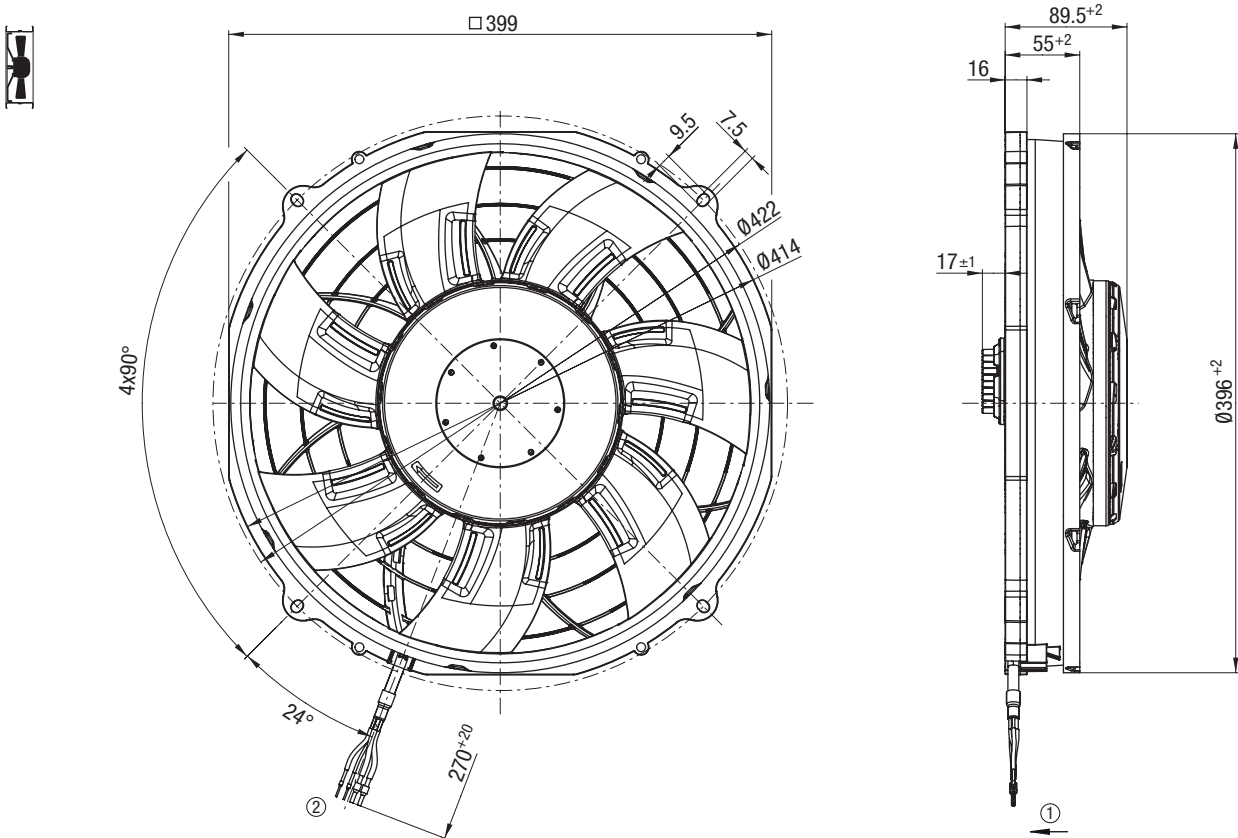

- ① Direction of air flow: "V"
- ② Cable (halogen-free):  
 BETAtrans<sup>®</sup> 3 GW 6 mm<sup>2</sup>, 2x crimped ferrules (brown, black)  
 BETAtrans<sup>®</sup> GW R 1.0 mm<sup>2</sup>, 2x crimped ferrules (yellow, white)

Pin assignment: see connection diagram

# EC / DC axial fans

Ø 300-350 mm, HyBlade



## Material/surface

- Impeller: PP plastic, black
- Housing: Painted black
- Rotor: Painted black
- Electronics housing: Die-cast aluminium

## Mechanical data

- Direction of rotation: Clockwise viewed toward rotor
- Direction of air flow: "A"
- Mode: Continuous operation (S1)
- Mounting: Maintenance-free ball bearings
- Cable exit: lateral

## Standards and approvals

- Conformity with standards: see page 6
- According to EN 45545-2 only for outside the passenger compartment application
- Approvals: EAC

on Page 80	Drawings
on Page 192	Connection diagrams and technical features
on Page 204	Technical parameters & scope
More at	<a href="http://www.ebmpapst.com">www.ebmpapst.com</a>

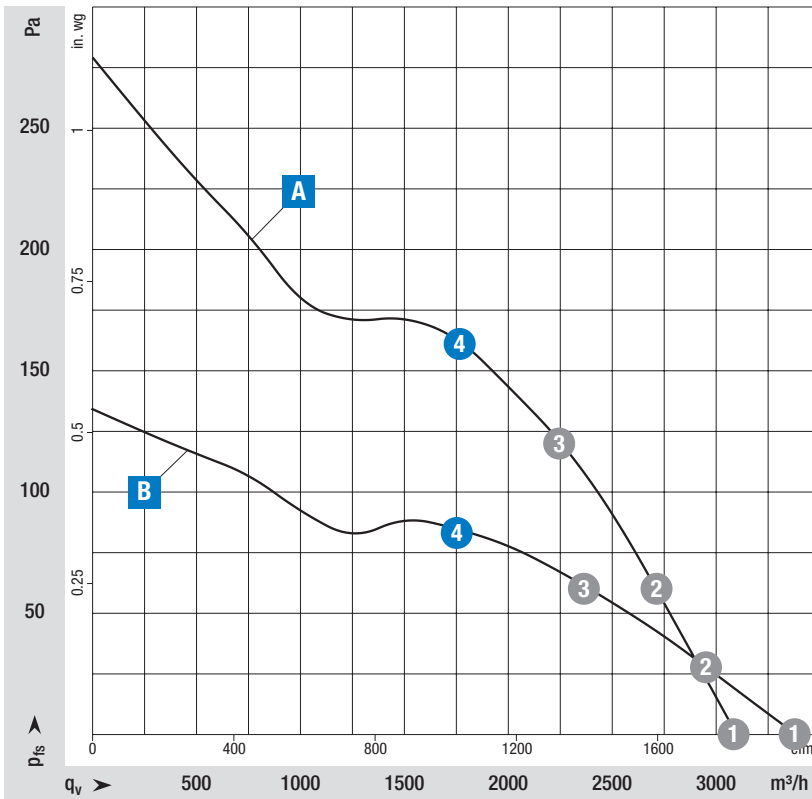

### Measuring requirements

Air performance measured according to: ISO 5801, installation category A, without contact protection.  
 Intake-side sound level:  $L_{pA}$  according to ISO 13347,  $L_{pA}$  measured at 1 m distance from fan axis. The values given are only applicable under the specified measuring conditions and may differ depending on the installation conditions. In the event of deviation from the standard configuration, the parameters must be checked in installed condition.

Curve	Operating point	Nominal voltage	Speed n	Max. Input power P <sub>ed</sub>	Max. Input current I	Sound power level L <sub>WA</sub>	Protection class	Installation position	Perm. ambient temp.	Degree of protection	Insulation class	Conn. diagram
		VDC	rpm	W	A	dB(A)						
Voltage range 77-138 V DC												
A	1	110	2350	165	1,50	73	I	Any	-40..+60	IP 6K9K	B	BA5)
	2	110	2350	202	1,80	73						
	3	110	2325	230	2,00	73						
	4	110	2250	230	2,00	75						
B	1	110	1490	135	1,20	69	I	Any	-40..+60	IP 6K9K	B	BA5)
	2	110	1415	135	1,20	66						
	3	110	1350	135	1,20	63						
	4	110	1300	135	1,20	66						

Values set in blue are nominal data at operating point with maximum load.

Subject to change

Curve		
	Axial fan	
	Part number	Weight
		kg
A	W3G300CT80P1	4,20
B	W3G350CT81P1	4,80

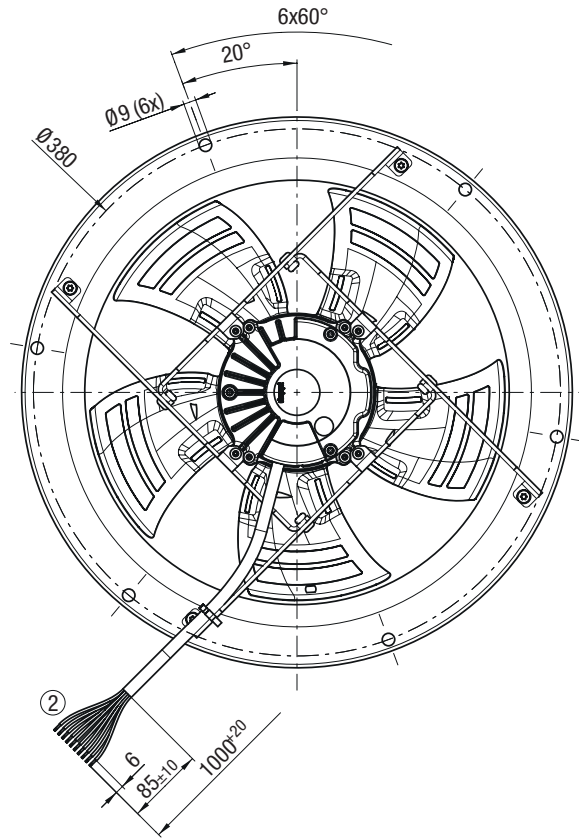
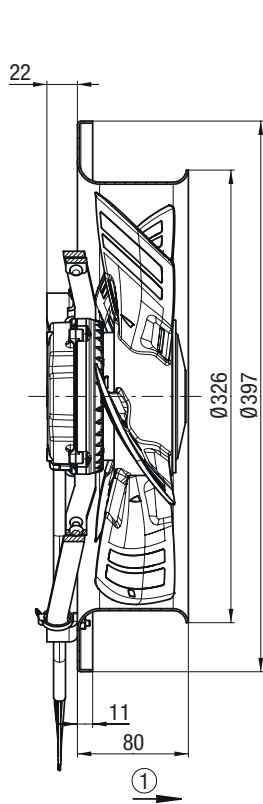

- ① Direction of air flow: "A"
- ② Cable (halogen-free):  
BETAtrans® GWK Flex R, 10G 1.0 mm<sup>2</sup>, 10x crimped splices

Pin assignment: see connection diagram

**B** W3G350CT81P1 (Axial fan)

Dimensions in mm

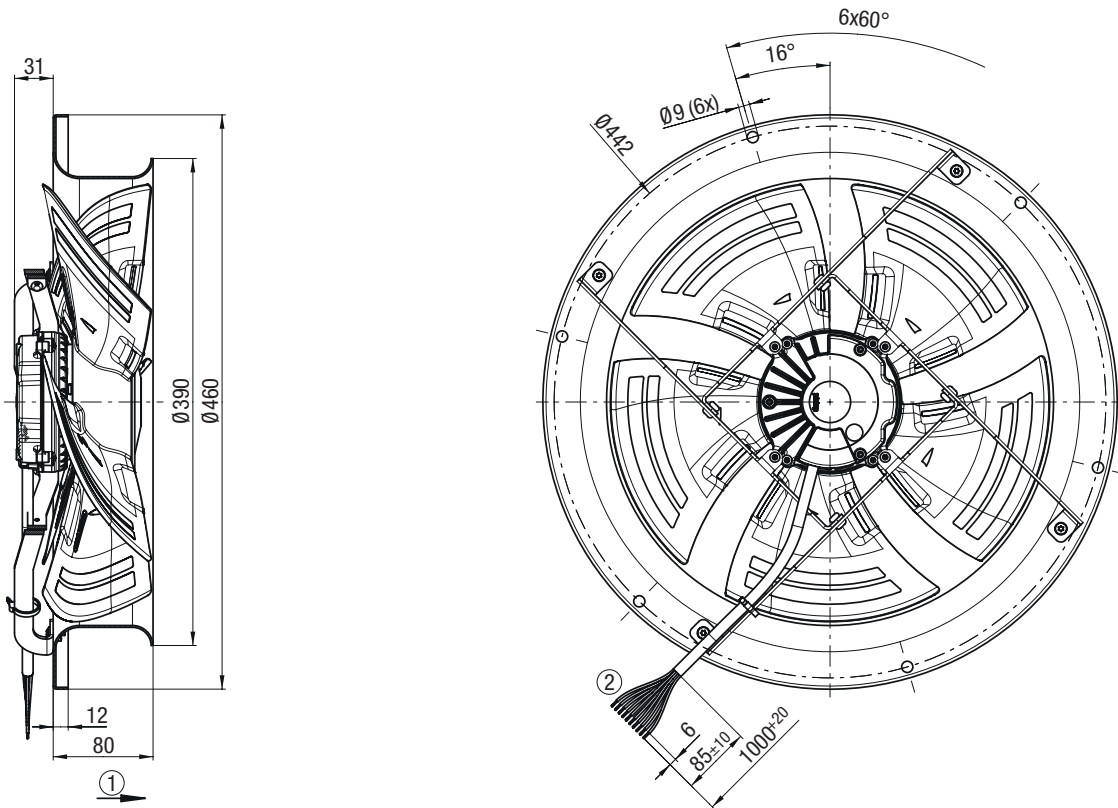

- ① Direction of air flow: "A"
- ② Cable (halogen-free):  
BETAtrans® GWK Flex R, 10G 1.0 mm<sup>2</sup>, 10x crimped splices

Pin assignment: see connection diagram

# EC / DC axial fans

Ø 400 mm, HyBlade

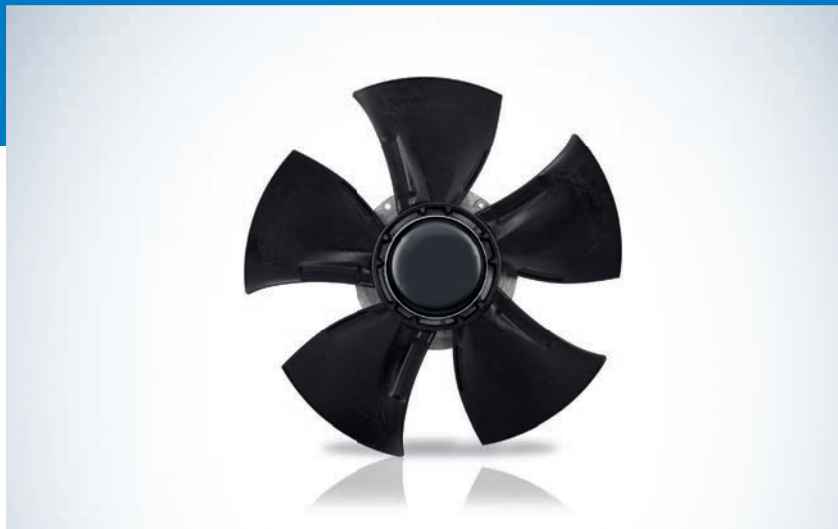

on Page 84	Drawings
on Page 192	Connection diagrams and technical features
on Page 204	Technical parameters & scope
More at	<a href="http://www.ebmpapst.com">www.ebmpapst.com</a>

## Material/surface

- Impeller: PA66 plastic, sheet-metal plate painted black
- Housing: Sheet steel, galvanized and coated with black plastic
- Support ring: Stainless steel
- Rotor: Painted black
- Electronics housing: Die-cast aluminium

## Mechanical data

- Direction of rotation: Clockwise viewed toward rotor
- Direction of air flow: "A"
- Mode: Continuous operation (S1)
- Mounting: Maintenance-free ball bearings
- Cable exit: lateral

## Standards and approvals

- Conformity with standards: see page 6
- Approvals: EAC

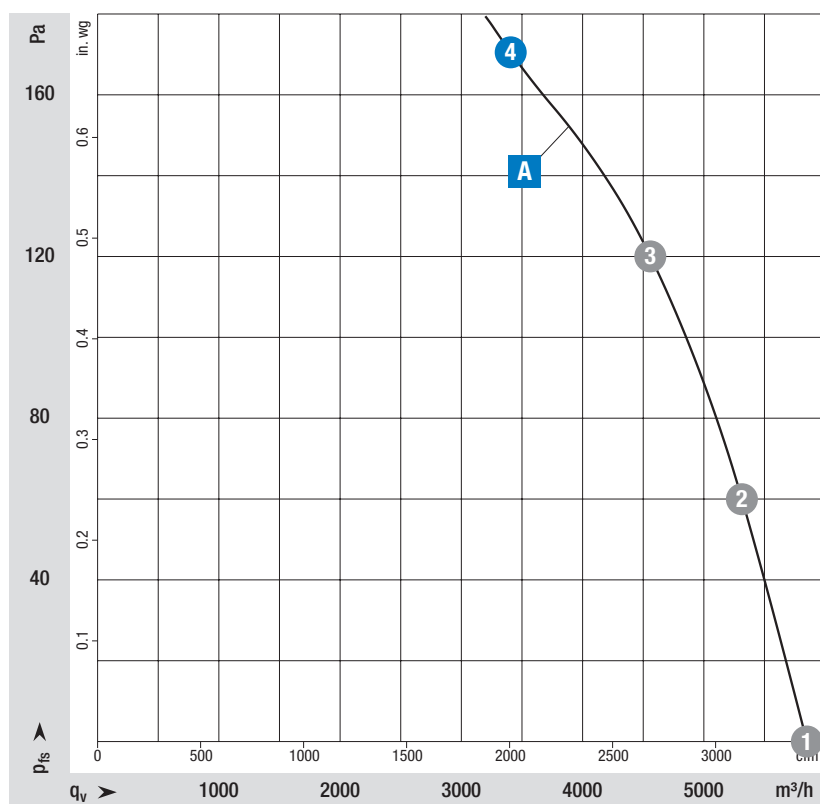

### Measuring requirements

Air performance measured according to: ISO 5801, installation category A, without contact protection.  
 Intake-side sound level: L<sub>wA</sub> according to ISO 13347, L<sub>pA</sub> measured at 1 m distance from fan axis. The values given are only applicable under the specified measuring conditions and may differ depending on the installation conditions. In the event of deviation from the standard configuration, the parameters must be checked in installed condition.

Curve	Operating point	Nominal voltage	Speed n	Max. Input power P <sub>ed</sub>	Max. Input current I	Sound power level L <sub>WA</sub>	Max. back pressure	Protection class	Installation position	Perm. ambient temp.	Degree of protection	Insulation class	Conn. diagram
		VDC	rpm	W	A	dB(A)	Pa			°C			
Voltage range 77-138 V DC													
A	1	110	1695	404	3,70	79	170	I	Shaft horizontal or rotor on top	-40..+60	IP 55 acc. to EN 60529	F	BA5)
	2	110	1700	439	4,00	77							
	3	110	1690	460	4,20	74							
	4	110	1670	460	4,20	79							

Values set in blue are nominal data at operating point with maximum load.

Subject to change

Curve	Axial fan		with round full nozzle	
	Part number	Weight kg	Part number	Weight kg
A	A3G400BK13P3	4,70	W3G400CK13P3	10,50

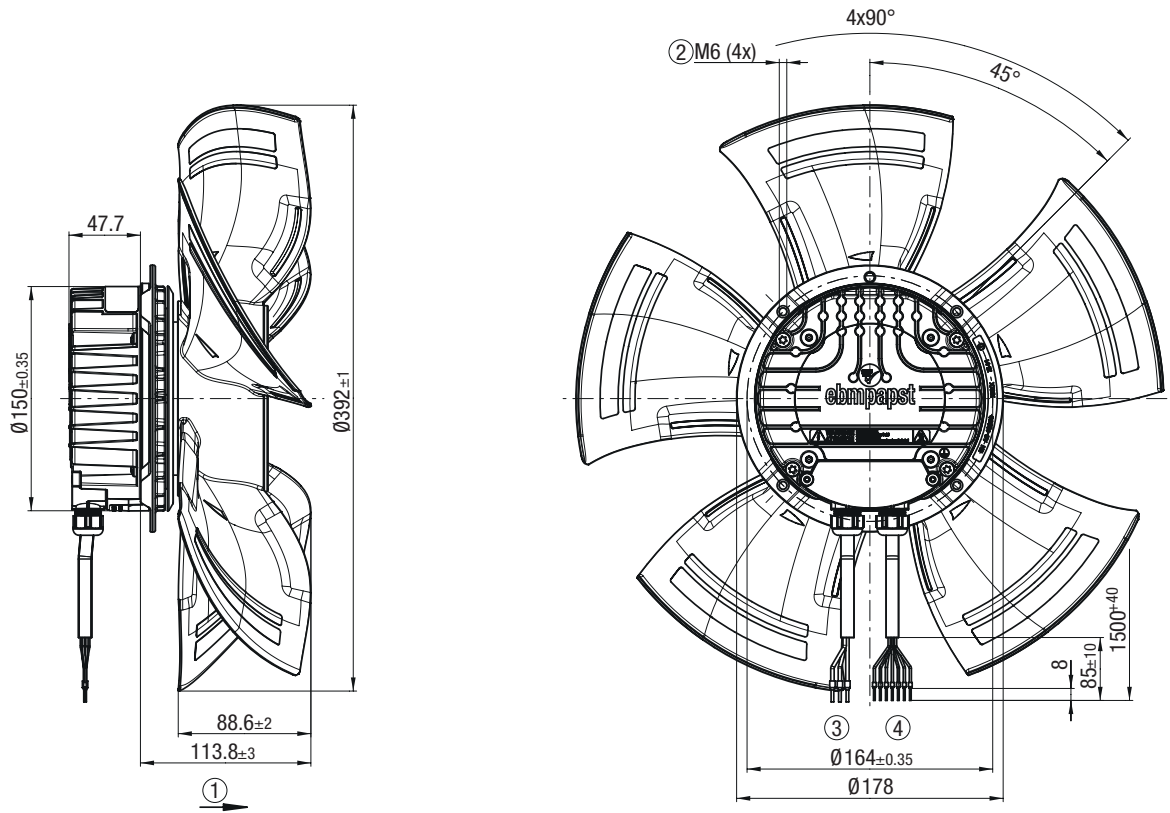

- ① Direction of air flow: "A"
- ② Max. clearance of screw: max. 16 mm
- ③ Cable (halogen-free): 3x BETAtrans<sup>®</sup> 3 GW flex, 4G 1.5 mm<sup>2</sup>, 3x crimped ferrules
- ④ Cable (halogen-free): 7x BETAtrans<sup>®</sup> 3 GW flex, 7x 0.5 mm<sup>2</sup>, 7x crimped ferrules

Pin assignment: see connection diagram



**A** W3G400CK13P3 (Axial fan with round full nozzle)

Dimensions in mm

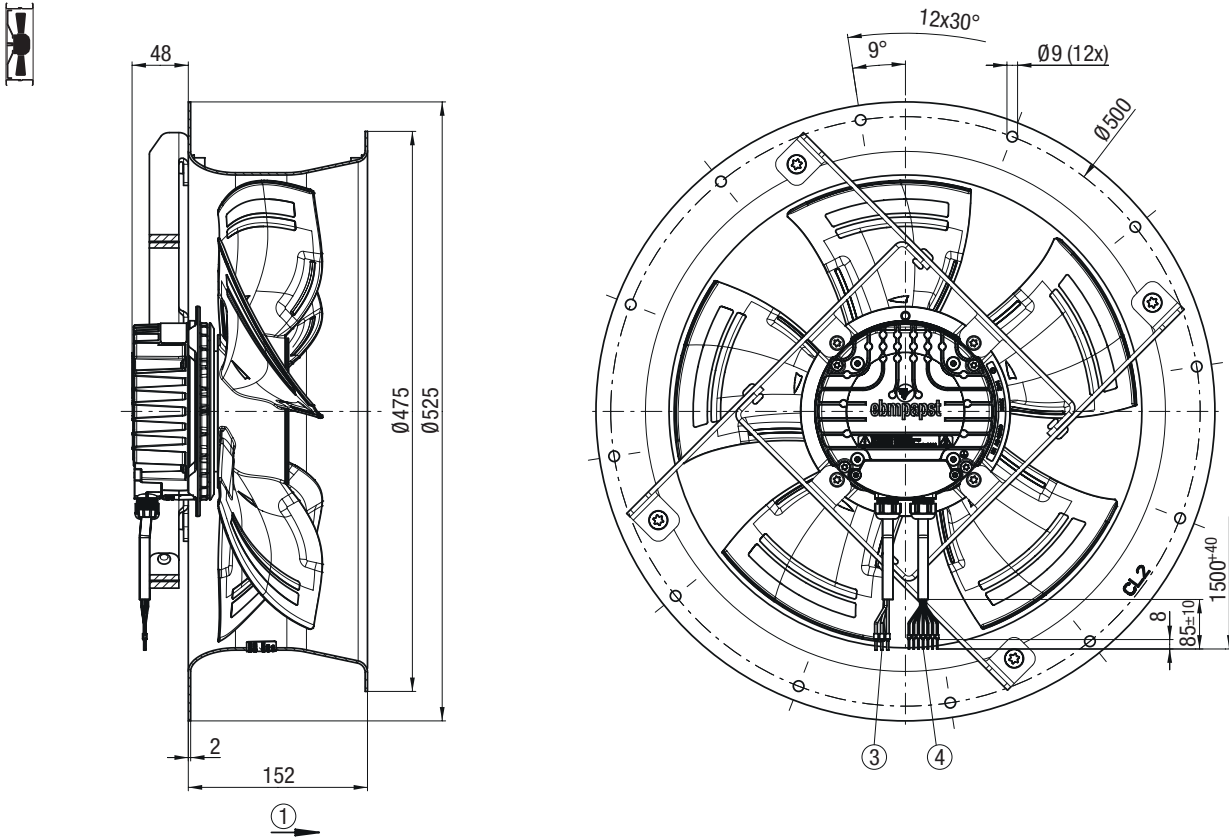

- ① Direction of air flow: "A"
- ③ Cable (halogen-free): 3x BETAtrans<sup>®</sup> 3 GW flex, 4G 1.5 mm<sup>2</sup>, 3x crimped ferrules
- ④ Cable (halogen-free): 7x BETAtrans<sup>®</sup> 3 GW flex, 7x 0.5 mm<sup>2</sup>, 7x crimped ferrules

Pin assignment: see connection diagram

# EC / DC axial fans

Ø 450 mm, HyBlade



on Page 88	Drawings
on Page 192	Connection diagrams and technical features
on Page 204	Technical parameters & scope
More at	<a href="http://www.ebmpapst.com">www.ebmpapst.com</a>

## Material/surface

- Impeller: PA66 plastic, sheet-metal plate painted black
- Housing: Sheet steel, galvanized and coated with black plastic
- Support ring: Stainless steel
- Rotor: Painted black
- Electronics housing: Die-cast aluminium

## Mechanical data

- Direction of rotation: Clockwise viewed toward rotor
- Direction of air flow: "A"
- Mode: Continuous operation (S1)
- Mounting: Maintenance-free ball bearings
- Cable exit: lateral

## Standards and approvals

- Conformity with standards: see page 6
- Approvals: EAC

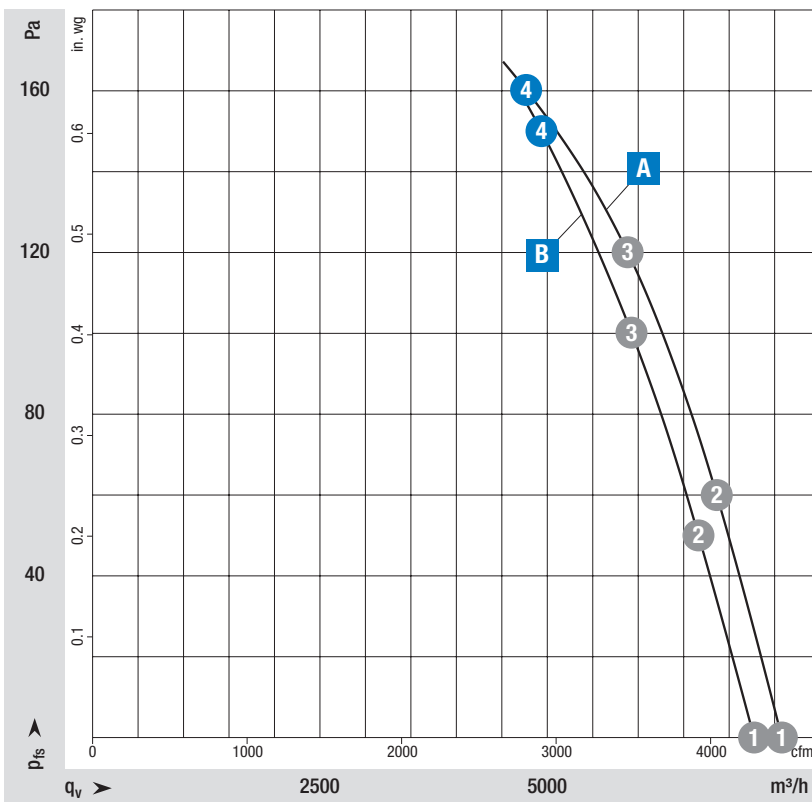

### Measuring requirements

Air performance measured according to: ISO 5801, installation category A, without contact protection.  
 Intake-side sound level:  $L_{pA}$  according to ISO 13347,  $L_{pA}$  measured at 1 m distance from fan axis. The values given are only applicable under the specified measuring conditions and may differ depending on the installation conditions. In the event of deviation from the standard configuration, the parameters must be checked in installed condition.

Curve	Operating point	Nominal voltage	Speed n	Max. Input power P <sub>ed</sub>	Max. Input current I	Sound power level L <sub>WA</sub>	Max. back pressure	Protection class	Installation position	Perm. ambient temp.	Degree of protection	Insulation class	Conn. diagram
		VDC	rpm	W	A	dB(A)							
Voltage range 77-138 V DC													
A	1	110	1550	429	3,90	76	160	I	Shaft horizontal or rotor on top	-40..+60	IP 55 acc. to EN 60529	F	BA6)
	2	110	1550	490	4,50	72							
	3	110	1535	530	4,80	71							
	4	110	1500	530	4,80	75							
Nominal voltage range 380-480 V AC													
B	1	400	1500	391	0,66	76	150	I	Shaft horizontal or rotor on top	-40..+60	IP 55 acc. to EN 60529	F	BA7)
	2	400	1500	441	0,73	72							
	3	400	1500	481	0,78	70							
	4	400	1500	500	0,83	72							

Values set in blue are nominal data at operating point with maximum load.

Subject to change

Curve	Axial fan		with round full nozzle	
	Part number	Weight kg	Part number	Weight kg
A	A3G450BL17P3	5,00	W3G450CL17P3	12,00
B	A3G450BL12N1	5,30	W3G450CL12N1	12,30

**A** A3G450BL17P3 (Axial fan)

Dimensions in mm

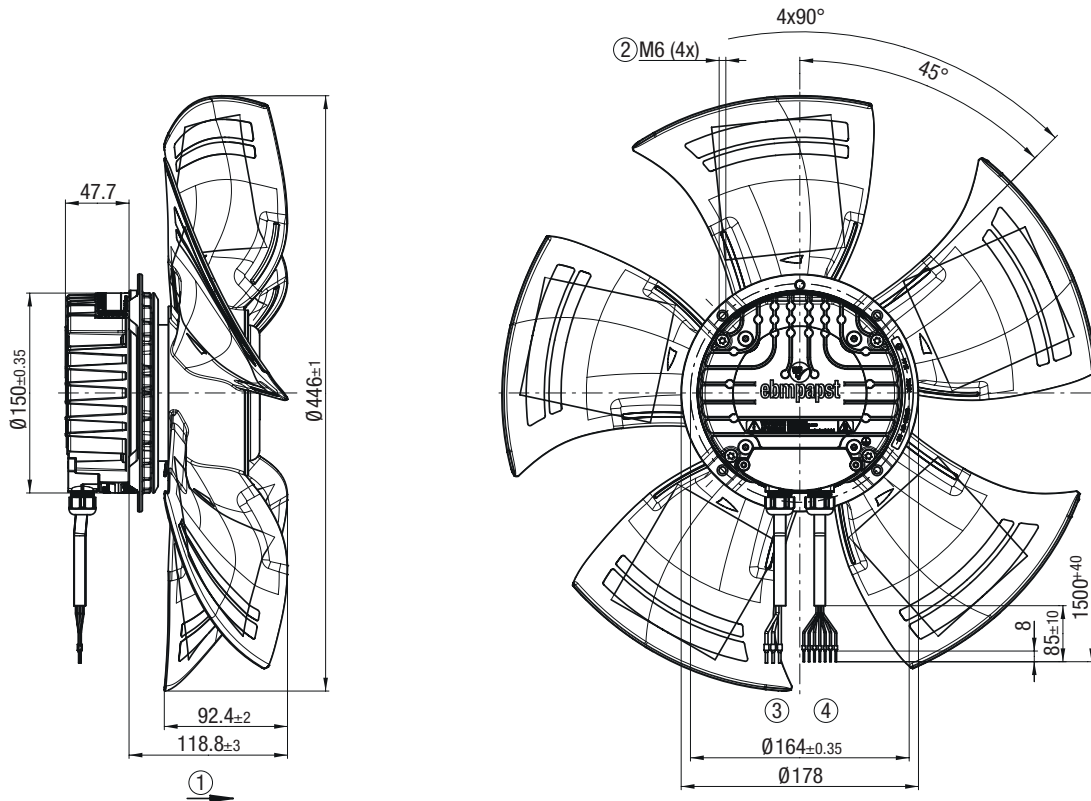

**A** W3G450CL17P3 (Axial fan with round full nozzle)

Dimensions in mm

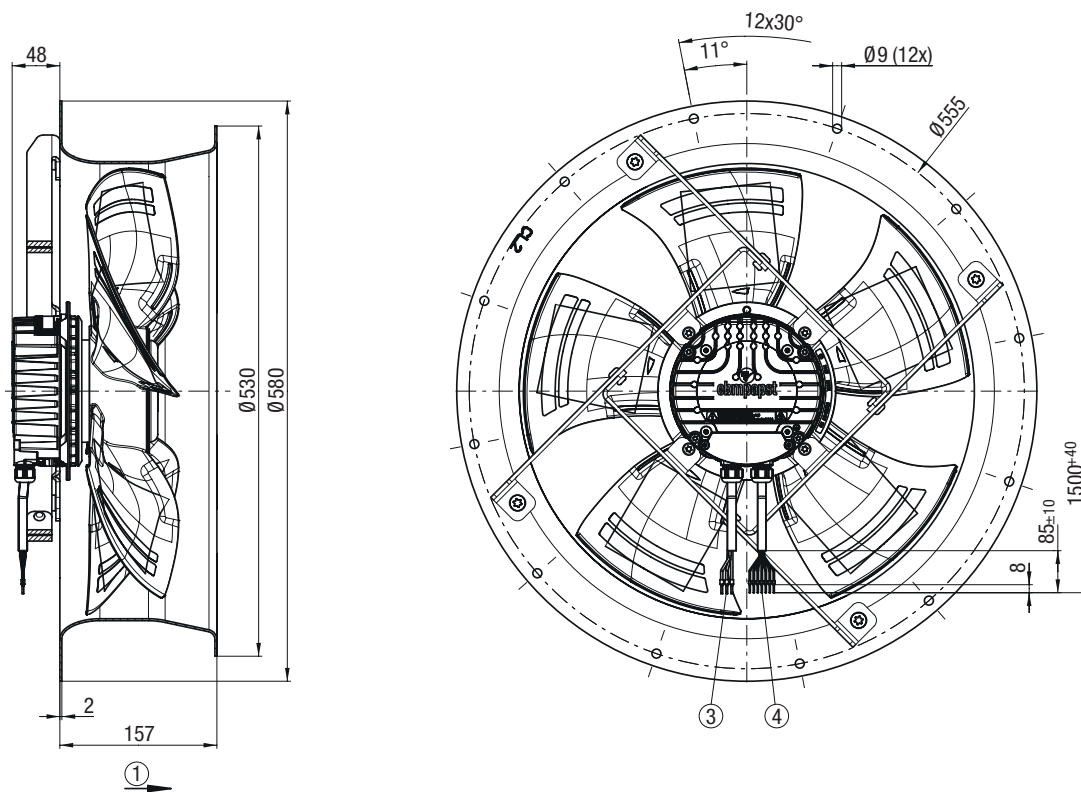

- ① Direction of air flow: "A"
- ② Max. clearance of screw: max. 16 mm
- ③ Cable (halogen-free): 3x BETAtrans<sup>®</sup> 3 GKW flex, 4G 1.5 mm<sup>2</sup>, 3x crimped ferrules
- ④ Cable (halogen-free): 7x BETAtrans<sup>®</sup> 3 GKW flex, 7x 0.5 mm<sup>2</sup>, 7x crimped ferrules

Pin assignment: see connection diagram

**B A3G450BL12N1 (Axial fan)**

Dimensions in mm

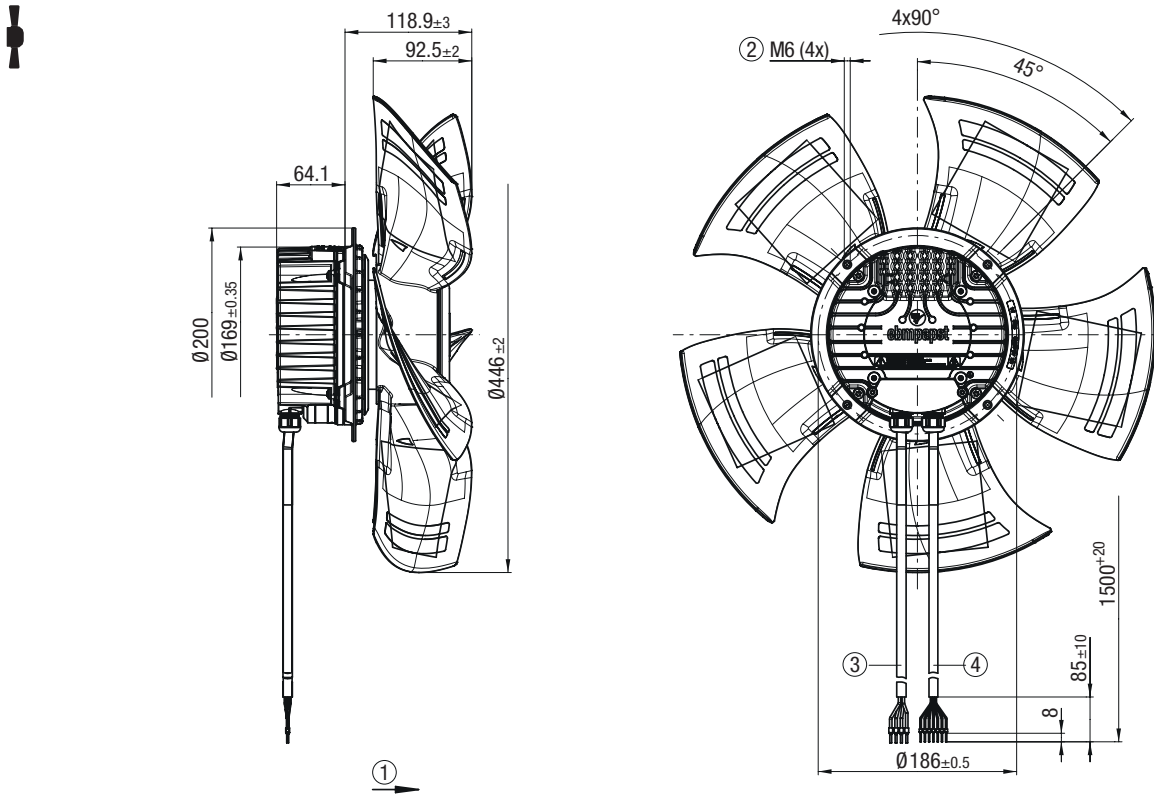

**B W3G450CL12N1 (Axial fan with round full nozzle)**

Dimensions in mm

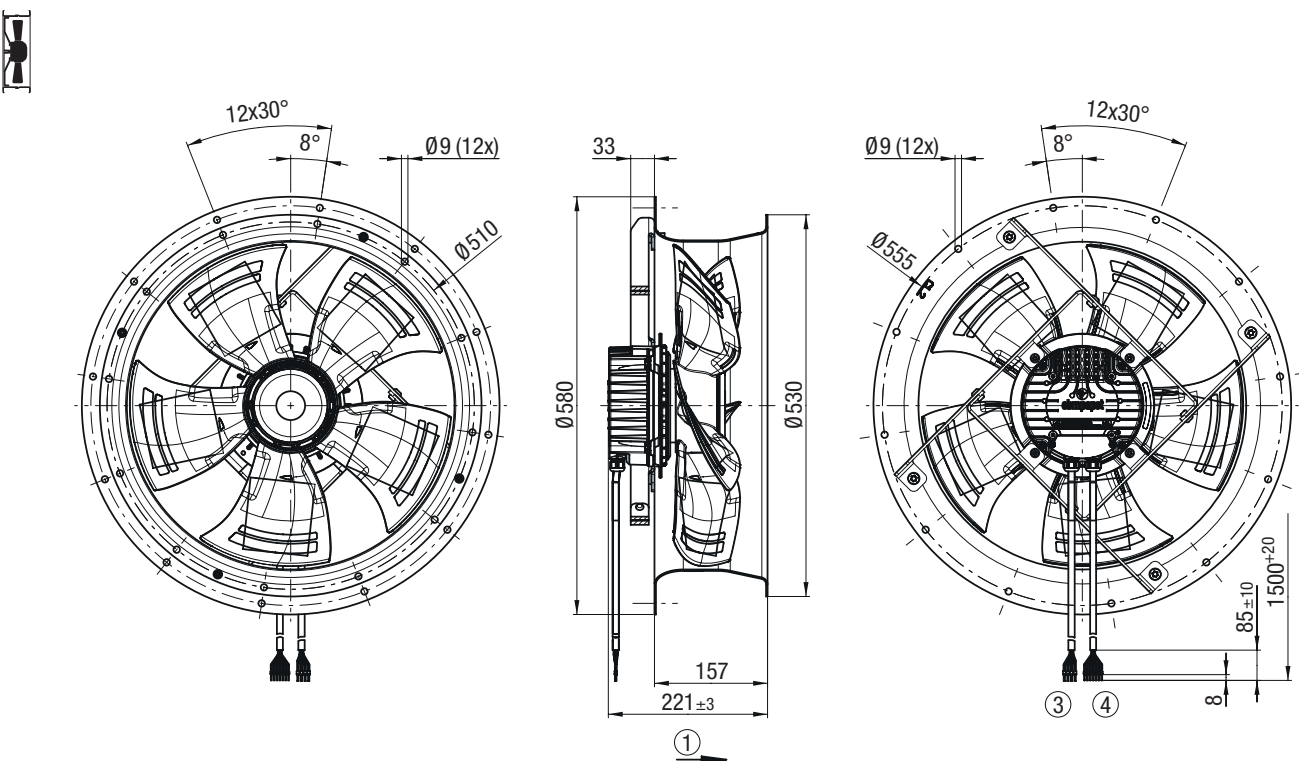

- ① Direction of air flow: "A"
- ② Max. clearance of screw: max. 16 mm
- ③ Cable (halogen-free): 3x BETAtans<sup>®</sup> 3 GKW flex, 4G 1.5 mm<sup>2</sup>, 3x crimped ferrules
- ④ Cable (halogen-free): 7x BETAtans<sup>®</sup> 3 GKW flex, 7x 0.5 mm<sup>2</sup>, 7x crimped ferrules

Pin assignment: see connection diagram

# EC / DC axial fans

Ø 500 mm, HyBlade



on Page 92	Drawings
on Page 192	Connection diagrams and technical features
on Page 204	Technical parameters & scope
More at	<a href="http://www.ebmpapst.com">www.ebmpapst.com</a>

## Material/surface

- Impeller: PA66 plastic
- Housing: Sheet steel, galvanized and coated with black plastic
- Support ring: Stainless steel
- Rotor: Painted black
- Electronics housing: Die-cast aluminium

## Mechanical data

- Direction of rotation: Clockwise viewed toward rotor
- Direction of air flow: "A"
- Mode: Continuous operation (S1)
- Mounting: Maintenance-free ball bearings
- Cable exit: lateral

## Standards and approvals

- Conformity with standards: see page 6
- Approvals: EAC

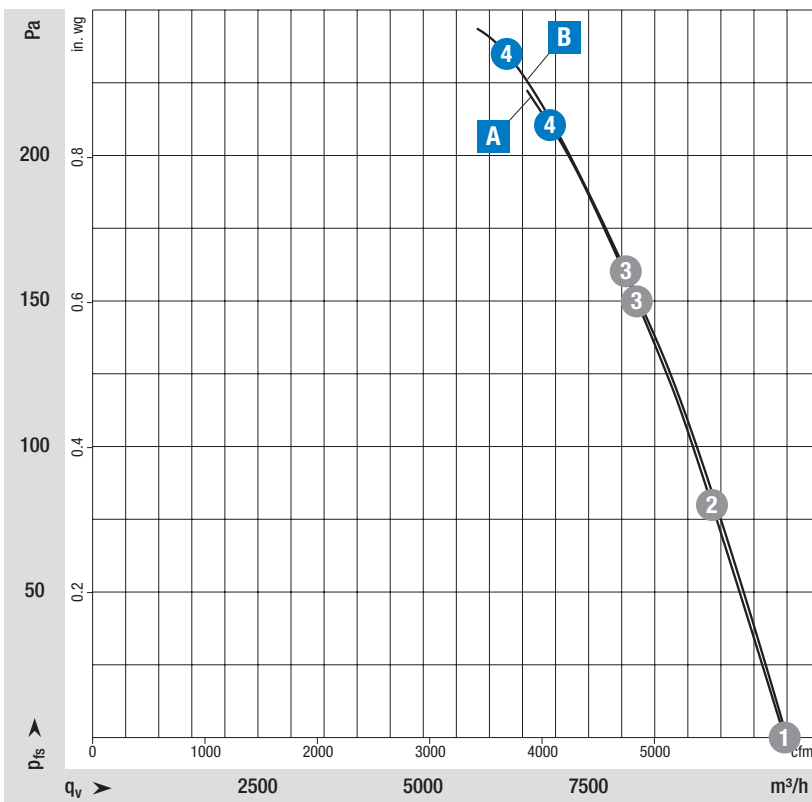

### Measuring requirements

Air performance measured according to: ISO 5801, installation category A, without contact protection.  
 Intake-side sound level:  $L_{wA}$  according to ISO 13347,  $L_{wA}$  measured at 1 m distance from fan axis. The values given are only applicable under the specified measuring conditions and may differ depending on the installation conditions. In the event of deviation from the standard configuration, the parameters must be checked in installed condition.

Curve	Operating point	Nominal voltage	Speed n	Max. Input power P <sub>ed</sub>	Max. Input current I	Sound power level L <sub>WA</sub>	Max. back pressure	Protection class	Installation position	Perm. ambient temp.	Degree of protection	Insulation class	Conn. diagram
		VDC	rpm	W	A	dB(A)							
Voltage range 77-138 V DC													
A	1	110	1600	735	6,70	84	210	I	Shaft horizontal or rotor on top	-40..+60	IP 55 acc. to EN 60529	F	BA6)
	2	110	1600	862	7,80	83							
	3	110	1600	963	8,80	81							
	4	110	1600	1020	9,30	79							
Nominal voltage range 380-480 V AC													
B	1	400	1600	718	1,12	82	235	I	Shaft horizontal or rotor on top	-40..+60	IP 55 acc. to EN 60529	F	BA7)
	2	400	1600	847	1,31	79							
	3	400	1600	942	1,45	79							
	4	400	1600	1000	1,60	81							

Values set in blue are nominal data at operating point with maximum load.

Subject to change

Curve	Axial fan		with round full nozzle	
	Part number	Weight kg	Part number	Weight kg
A	A3G500BA73S1	7,40	W3G500CA73S1	15,40
B	A3G500BA74N1	7,40	W3G500CA74N1	15,40

**A** A3G500BA73S1 (Axial fan)

Dimensions in mm

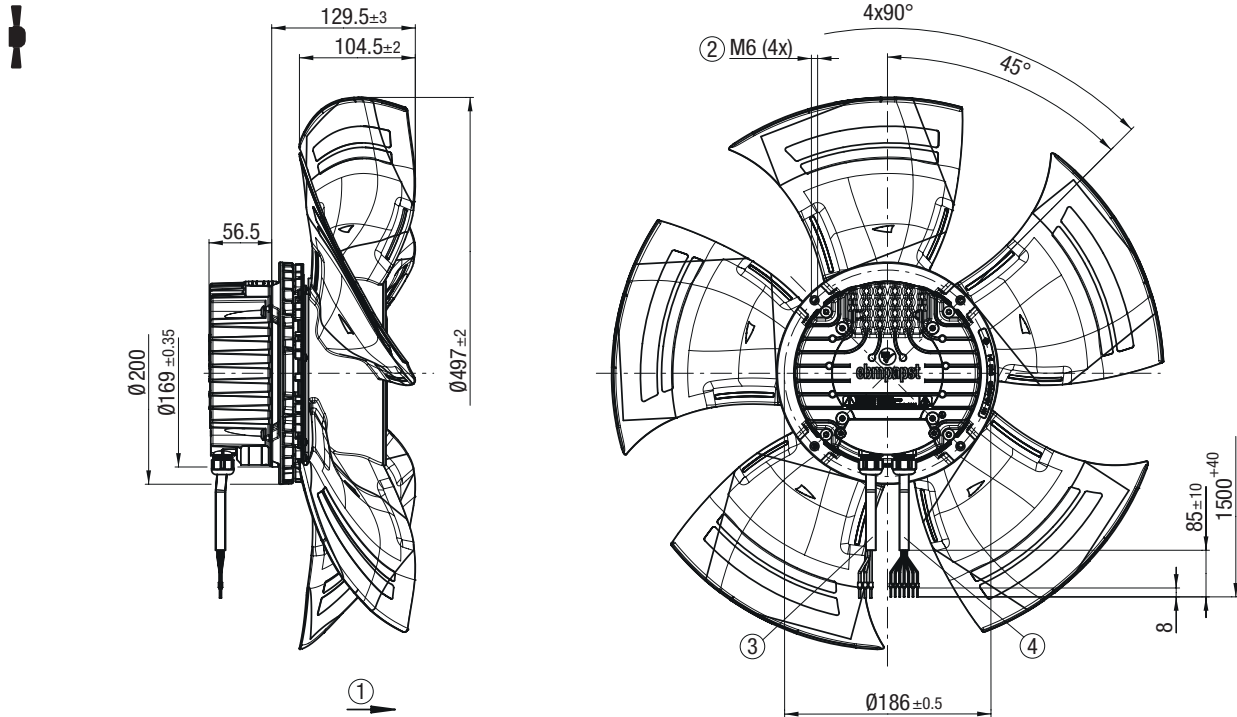

**A** W3G500CA73S1 (Axial fan with round full nozzle)

Dimensions in mm

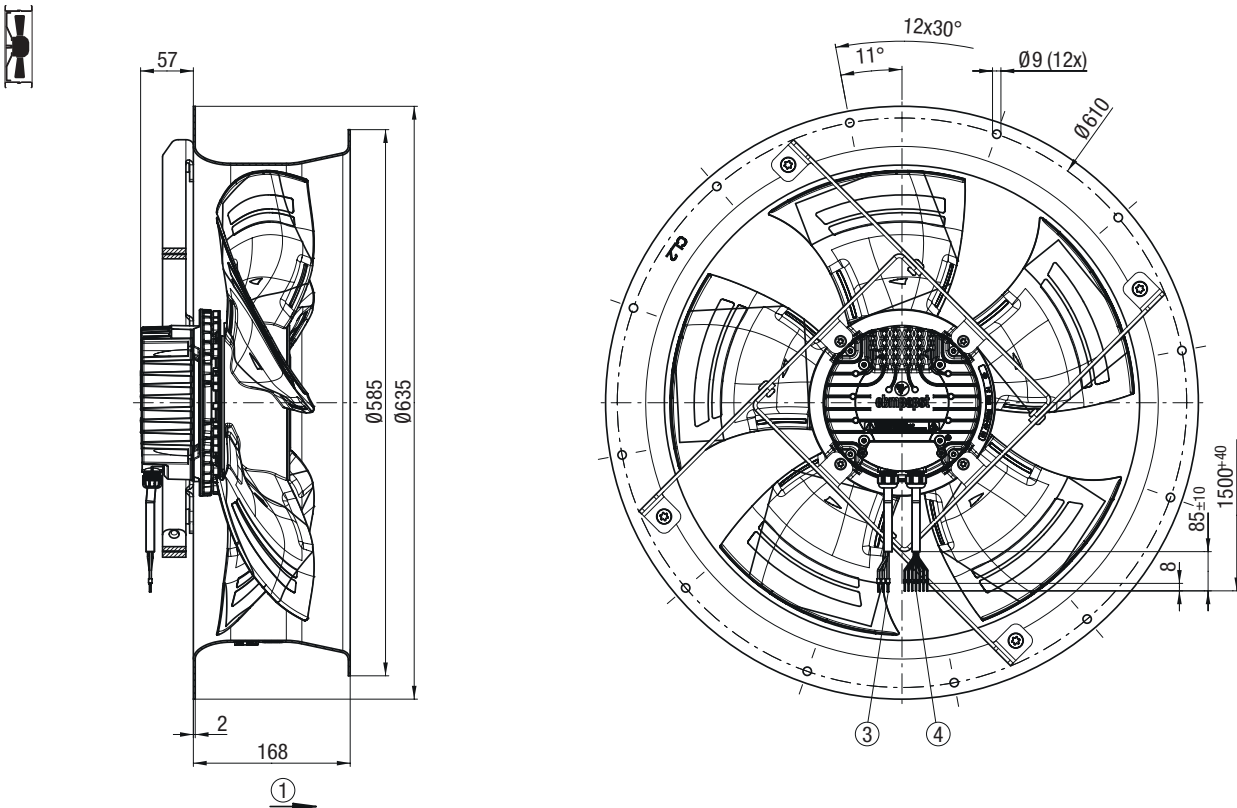

- ① Direction of air flow: "A"
- ② Max. clearance of screw: max. 16 mm
- ③ Cable (halogen-free): 3x BETAtrans<sup>®</sup> 3 GKW flex, 4G 1.5 mm<sup>2</sup>, 3x crimped ferrules
- ④ Cable (halogen-free): 7x BETAtrans<sup>®</sup> 3 GKW flex, 7x 0.5 mm<sup>2</sup>, 7x crimped ferrules

Pin assignment: see connection diagram



**B A3G500BA74N1 (Axial fan)**

Dimensions in mm

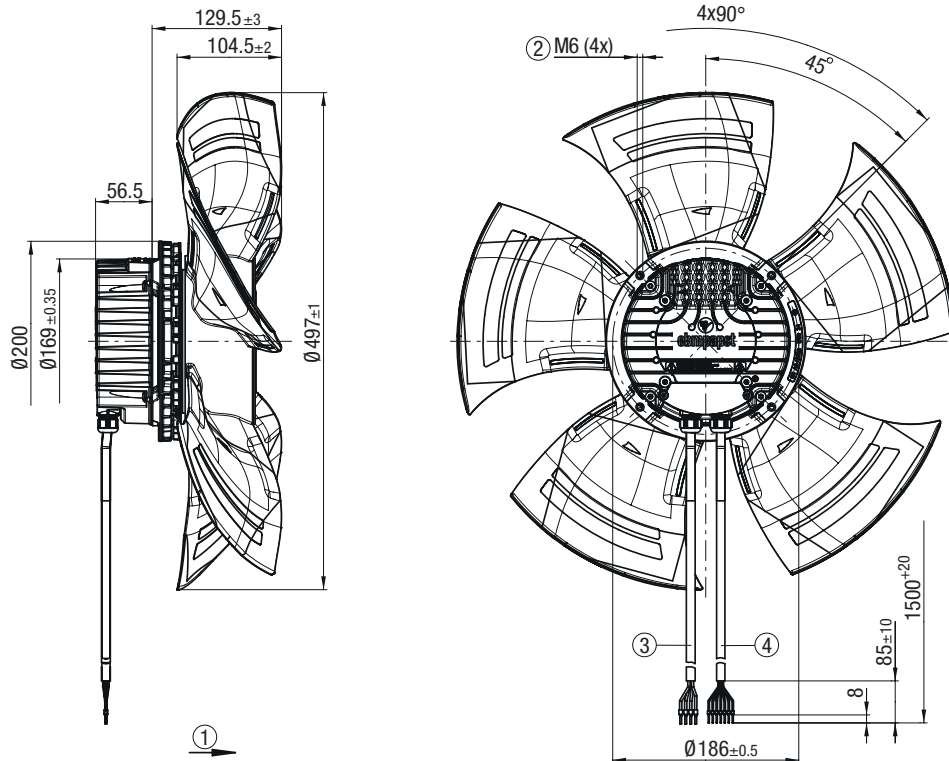

**B W3G500CA74N1 (Axial fan with round full nozzle)**

Dimensions in mm

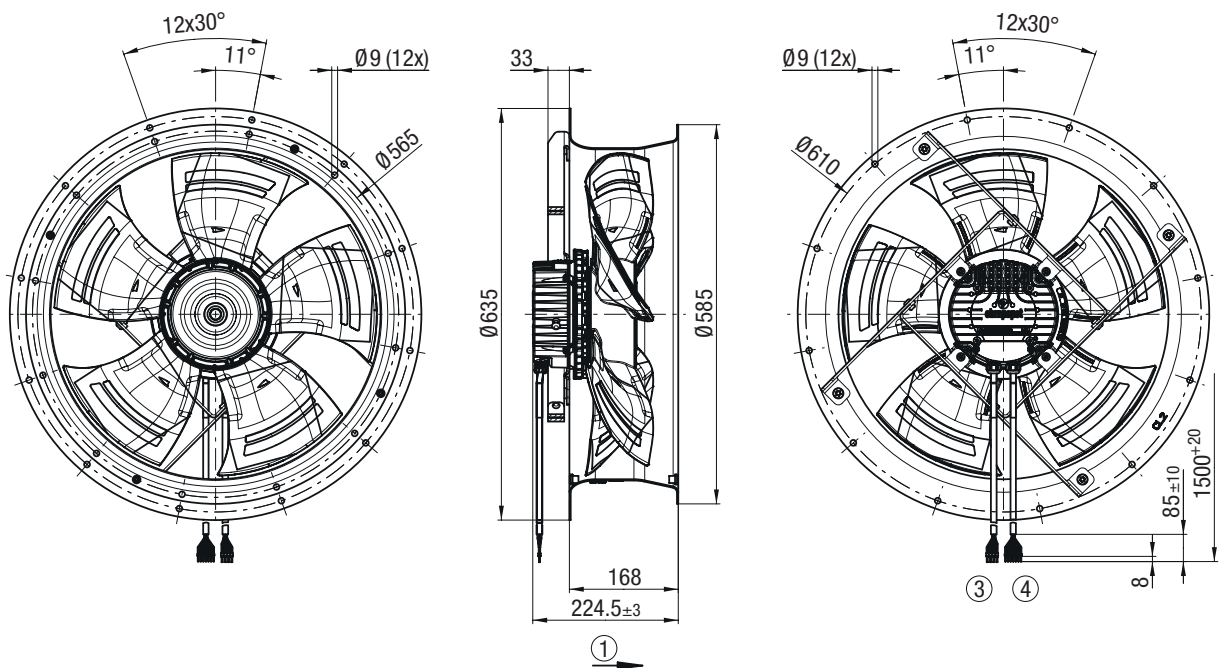

- ① Direction of air flow: "A"
- ② Max. clearance of screw: max. 16 mm
- ③ Cable (halogen-free): 3x BETAtans<sup>®</sup> 3 GKW flex, 4G 1.5 mm<sup>2</sup>, 3x crimped ferrules
- ④ Cable (halogen-free): 7x BETAtans<sup>®</sup> 3 GKW flex, 7x 0.5 mm<sup>2</sup>, 7x crimped ferrules

Pin assignment: see connection diagram



# DC compact fans

**ebmpapst**

the engineer's choice

	Page
Axial fan 6300 NTD	96
Centrifugal fan RLF 100	100

# DC axial fan

Ø 172 x 51 mm



## Material/surface

- Impeller: Plastic, black
- Housing: Metal, black

## Mechanical data

- Direction of rotation: Counter-clockwise viewed toward rotor
- Direction of air flow: Blowing over struts
- Installation position: Any
- Mode: Continuous operation (S1)
- Mounting: Maintenance-free ball bearings
- Cable exit: lateral

## Electrical data

- Protection class: III

## Standards and approvals

- Conformity with standards: see page 6
- Approvals: EAC

on Page 98	Drawings
on Page 192	Connection diagrams and technical features
on Page 204	Technical parameters & scope
More at	<a href="http://www.ebmpapst.com">www.ebmpapst.com</a>

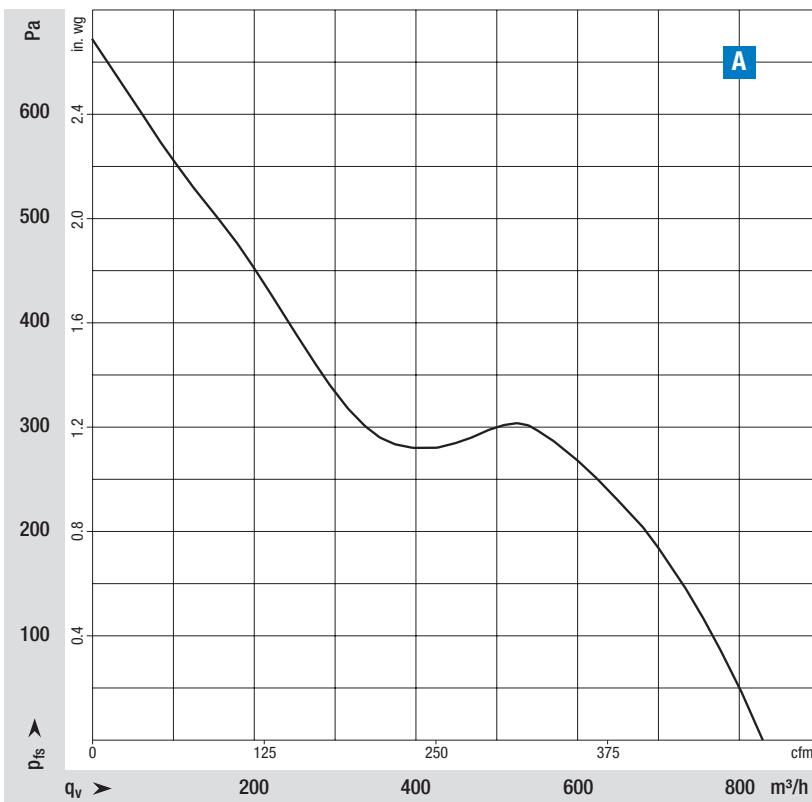

### Measuring requirements

Air performance measured according to: ISO 5801, installation category A, without contact protection.  
 Intake-side sound level:  $L_{pA}$  according to ISO 13347,  $L_{pA}$  measured at 1 m distance from fan axis. The values given are only applicable under the specified measuring conditions and may differ depending on the installation conditions. In the event of deviation from the standard configuration, the parameters must be checked in installed condition.

Curve	Nominal voltage VDC	Speed n rpm	Input power P <sub>ed</sub> W	Input current I A	Sound power level L <sub>WA</sub> dB(A)	Perm. ambient temp. °C	Degree of protection	Insulation class	Conn. diagram
Voltage range 16-36 V DC									
<b>A</b>	24	6000	90	3,75	79	-20..+70	IP 68	E	BA10)

Specification of nominal data: free blowing

Subject to change

Curve		
	Axial fan	
	Part number	Weight
<b>A</b>	6314N2TDHOU-305	0,85 kg

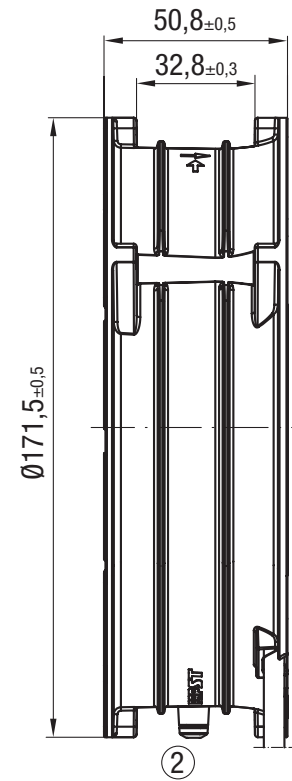
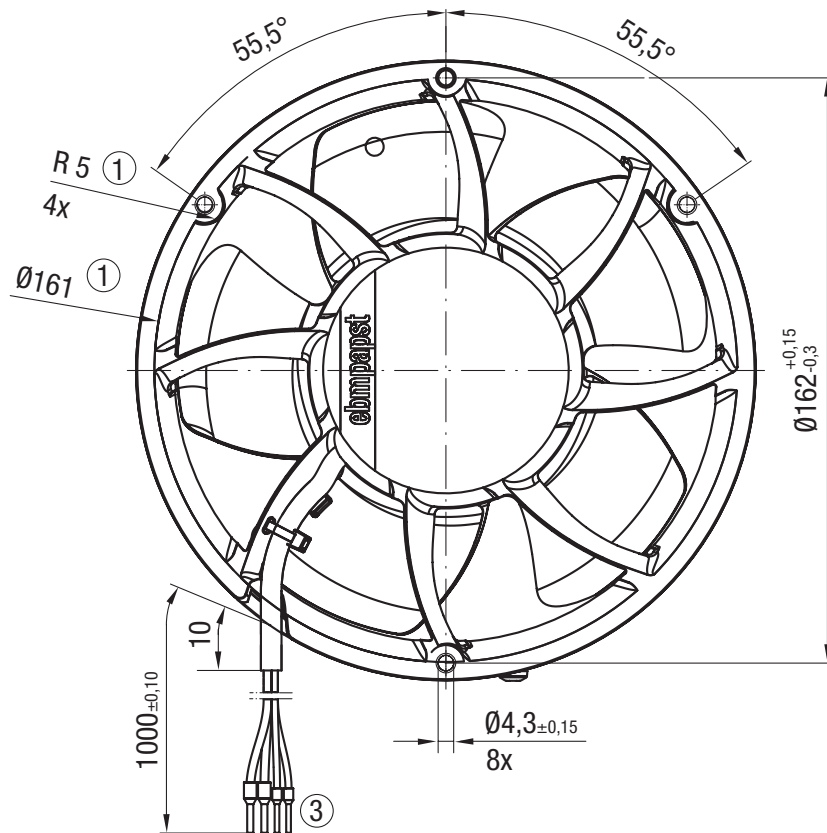

- ① Dimensions: for mounting cutout
- ② Screw: Duo-Taptite according to DIN 7500, CM 4x8, Torx
- ③ Cable: 2x AWG 22 und 2x AWG 18, 4x crimped ferrules

Pin assignment: see connection diagram



# DC centrifugal fan

□ 127 x 25 mm



## Material/surface

- Impeller: Plastic
- Housing: Plastic
- Housing bottom: Sheet steel

## Mechanical data

- Direction of rotation: Clockwise viewed toward rotor
- Direction of air flow: axial sucking in, radial blowing out
- Installation position: Any
- Mode: Continuous operation (S1)
- Mounting: Maintenance-free ball bearings
- Cable exit: lateral

## Electrical data

- Protection class: III

## Standards and approvals

- Conformity with standards: on request
- Approvals: EAC

on Page 102	Drawings
on Page 192	Connection diagrams and technical features
on Page 204	Technical parameters & scope
More at	<a href="http://www.ebmpapst.com">www.ebmpapst.com</a>

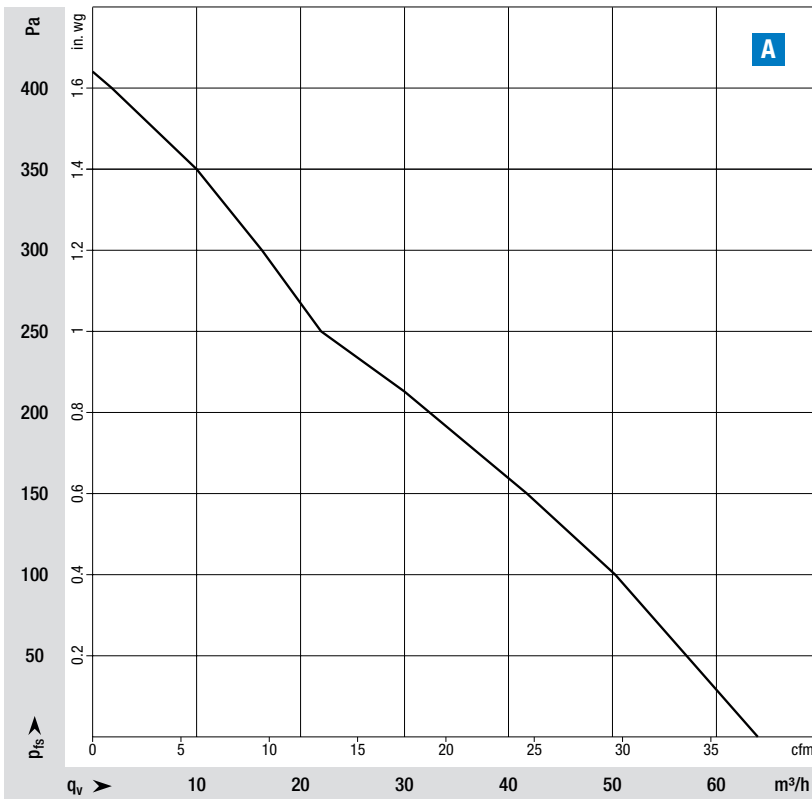

### Measuring requirements

Air performance measured according to: ISO 5801, installation category A, with ebmpapst scroll housing without contact protection.  
Intake-side sound level:  $L_{wA}$  measured according to ISO 10302. The values given are only applicable under the specified measuring conditions and may differ depending on the installation conditions. In the event of deviation from the standard configuration, the parameters must be checked in installed condition.



Curve	Nominal voltage VDC	Speed n rpm	Input power P <sub>ed</sub> W	Input current I A	Sound power level L <sub>WA</sub> dB(A)	Perm. ambient temp. °C	Degree of protection	Insulation class	Conn. diagram
Voltage range 18-28 V DC									
<b>A</b>	24	5100	7,7	0,32	64	-20..+70	IP 54	E	BA11)

Specification of nominal data: free blowing

Subject to change

Curve		
	Centrifugal fan	
	Part number	Weight
		kg
<b>A</b>	RLF100-11/14PU-217	0,30

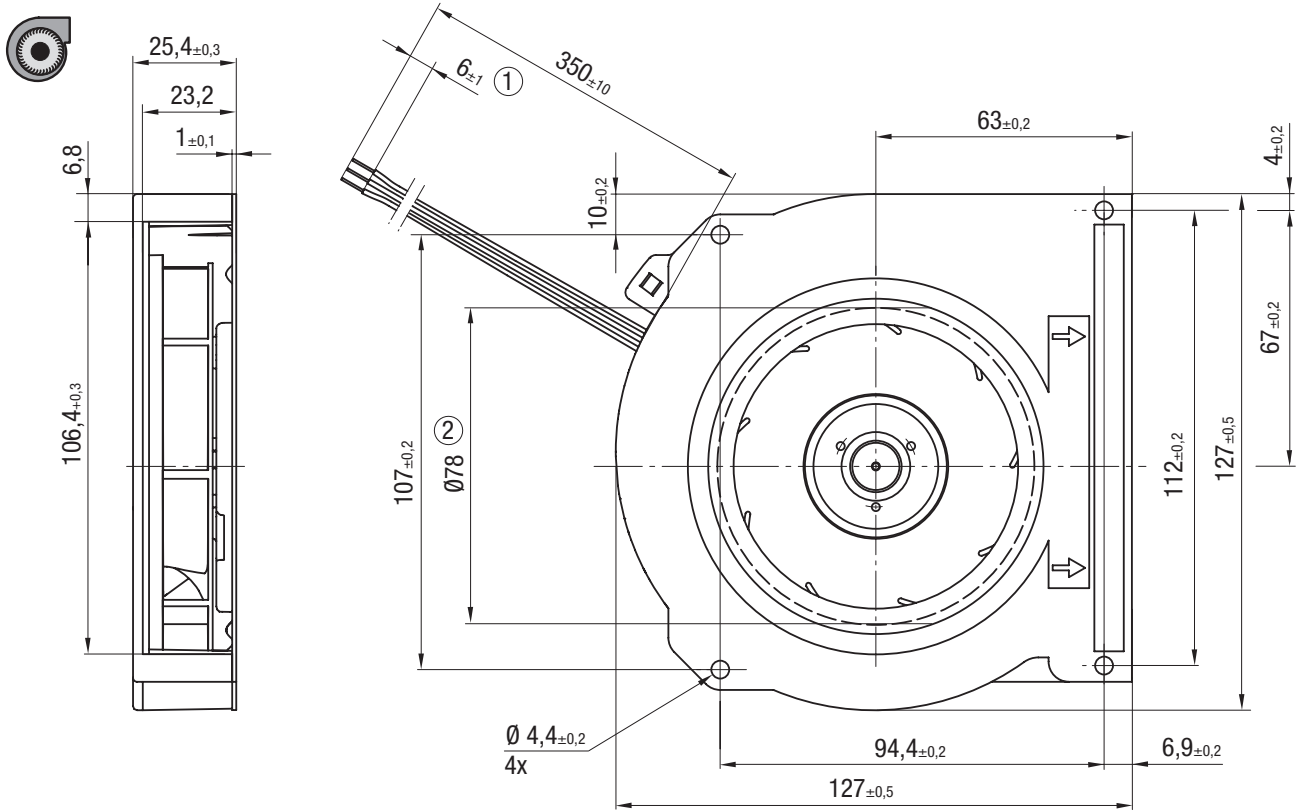

① Cable: 3x AWG 22

Pin assignment: see connection diagram





# AC centrifugal fans *backward curved* Ø 190 - Ø 280

**ebmpapst**

the engineer's choice

	Page
Ø 190 RadiCal	106
Ø 220 RadiCal	110
Ø 250 RadiCal	114
Ø 280 RadiCal	118

# AC centrifugal fans

backward curved,  $\varnothing 190$  mm



### Material/surface

- Impeller: PA66 plastic, sheet-metal plate painted black
- Rotor: Painted black

### Mechanical data

- Direction of rotation: Clockwise viewed toward rotor
- Mode: Continuous operation (S1)
- Mounting: Maintenance-free ball bearings
- Cable exit: axial

### Standards and approvals

- Conformity with standards: see page 6
- Approvals: EAC

on Page 108	Drawings
on Page 182	Accessories
on Page 192	Connection diagrams and technical features
on Page 204	Technical parameters & scope
More at	<a href="http://www.ebmpapst.com">www.ebmpapst.com</a>

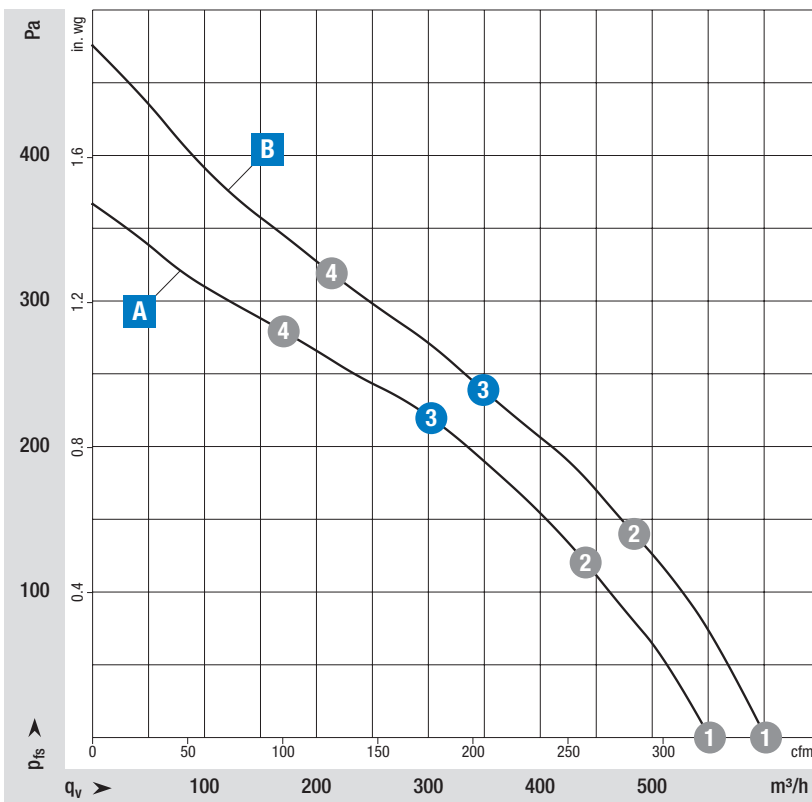

**Measuring requirements**  
 Air performance measured according to: ISO 5801, installation category A, with ebmpapst inlet ring without contact protection.  
 Intake-side sound level:  $L_{pA}$  according to ISO 13347,  $L_{pA}$  measured at 1 m distance from fan axis. The values given are only applicable under the specified measuring conditions and may differ depending on the installation conditions. In the event of deviation from the standard configuration, the parameters must be checked in installed condition.

Curve	Operating point	Nominal voltage		Max. Input power $P_{ed}$	Max. Input current I	Sound power level $L_{wA}$	Protection class	Installation position	Perm. ambient temp.	Degree of protection	Insulation class	Conn. diagram
		VDC	rpm									
Nominal voltage 400 V AC, 50 Hz												
A	①	400Y	2665	42	0,08	68	I	Shaft horizontal or rotor on bottom	-40..+80	IP 44 installation- and position-dependent	F	BA9)
	②	400Y	2620	46	0,09	63						
	③	400Y	2550	50	0,09	62						
	④	400Y	2630	45	0,08	65						
Nominal voltage 400 V AC, 60 Hz												
B	①	400Y	2945	59	0,09	70	I	Shaft horizontal or rotor on bottom	-40..+80	IP 44 installation- and position-dependent	F	BA9)
	②	400Y	2855	65	0,10	65						
	③	400Y	2750	70	0,11	63						
	④	400Y	2855	64	0,10	67						

Values set in blue are nominal data at operating point with maximum load.

Subject to change

Curve		Centrifugal fan	
		Part number	Weight
			kg
A		R2D190RB1811	1,60
B			

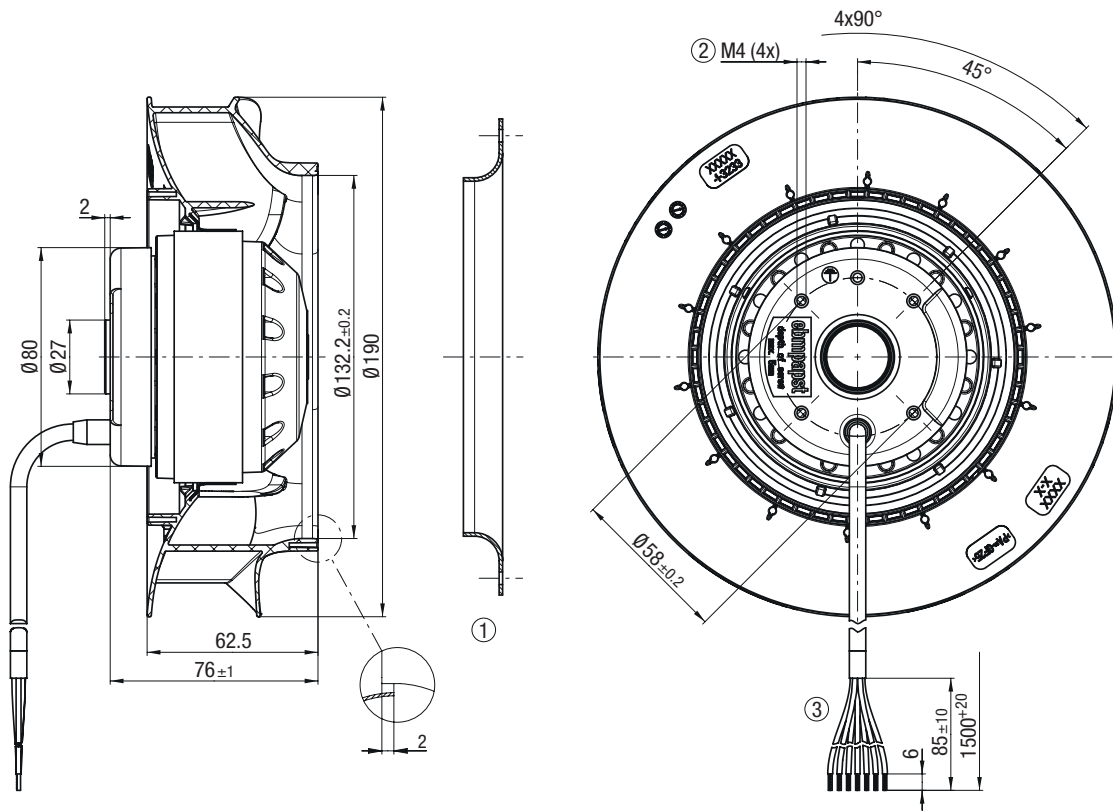

- ① **Accessory part:** Inlet ring 09576-2-4013, not included in scope of delivery  
Dimensions: see "Accessories" chapter
- ② **Max. clearance of screw:** max. 5 mm
- ③ **Cable (halogen-free):** 9x BETAtans<sup>®</sup> 3 GW flex, 9G 0.5 mm<sup>2</sup>, 9x crimped splices

**Pin assignment:** see connection diagram





# AC centrifugal fans

backward curved,  $\varnothing$  220 mm



### Material/surface

- Impeller: PA66 plastic, sheet-metal plate painted black
- Rotor: Painted black

### Mechanical data

- Direction of rotation: Clockwise viewed toward rotor
- Mode: Continuous operation (S1)
- Mounting: Maintenance-free ball bearings
- Cable exit: axial

### Standards and approvals

- Conformity with standards: see page 6
- Approvals: EAC

on Page 112	Drawings
on Page 182	Accessories
on Page 192	Connection diagrams and technical features
on Page 204	Technical parameters & scope
More at	<a href="http://www.ebmpapst.com">www.ebmpapst.com</a>

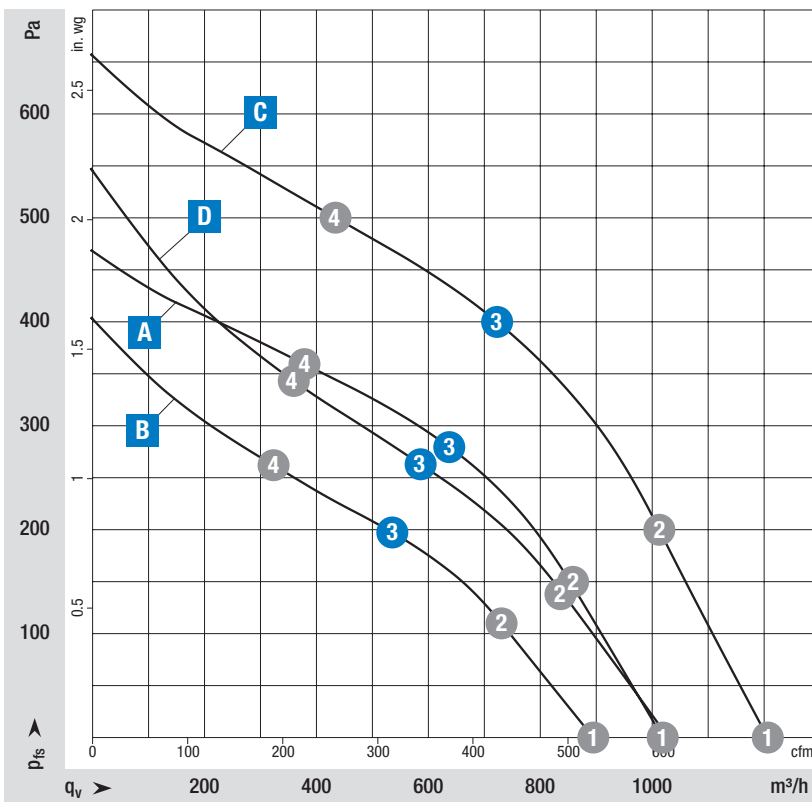

#### Measuring requirements

Air performance measured according to: ISO 5801, installation category A, with ebm-papst inlet ring without contact protection. Intake-side sound level:  $L_{pA}$  according to ISO 13347,  $L_{pA}$  measured at 1 m distance from fan axis. The values given are only applicable under the specified measuring conditions and may differ depending on the installation conditions. In the event of deviation from the standard configuration, the parameters must be checked in installed condition.

Curve	Operating point	Nominal voltage	Speed n	Max. Input power $P_{ed}$	Max. Input current I	Sound power level $L_{wA}$	Protection class	Installation position	Perm. ambient temp.	Degree of protection	Insulation class	Conn. diagram
		VDC										
Nominal voltage 400 V AC, 50 Hz												
A	1	400 Δ	2800	98	0,25	70	I	Shaft horizontal or rotor on bottom	-40..+70	IP 44 installation- and position-dependent	F	BA9)
	2	400 Δ	2765	110	0,26	67						
	3	<b>400 Δ</b>	<b>2750</b>	<b>120</b>	<b>0,27</b>	<b>65</b>						
	4	400 Δ	2755	111	0,26	68						
B	1	400 Y	2455	67	0,11	67	I	Shaft horizontal or rotor on bottom	-40..+80	IP 44 installation- and position-dependent	F	BA9)
	2	400 Y	2360	76	0,12	63						
	3	<b>400 Y</b>	<b>2300</b>	<b>82</b>	<b>0,13</b>	<b>61</b>						
	4	400 Y	2355	77	0,12	64						
Nominal voltage 480 V AC, 60 Hz												
C	1	480 Δ	3315	151	0,28	75	I	Shaft horizontal or rotor on bottom	-40..+60	IP 44 installation- and position-dependent	F	BA9)
	2	480 Δ	3260	171	0,29	71						
	3	<b>480 Δ</b>	<b>3200</b>	<b>190</b>	<b>0,31</b>	<b>69</b>						
	4	480 Δ	3255	173	0,29	73						
D	1	480 Y	2825	108	0,14	71	I	Shaft horizontal or rotor on bottom	-40..+80	IP 44 installation- and position-dependent	F	BA9)
	2	480 Y	2705	120	0,16	67						
	3	<b>480 Y</b>	<b>2600</b>	<b>130</b>	<b>0,17</b>	<b>64</b>						
	4	480 Y	2690	121	0,16	68						

Values set in blue are nominal data at operating point with maximum load.

Subject to change

Curve		
	Centrifugal fan	
	Part number	Weight
A	R2D220RC3611	2,10
B		
C		
D		

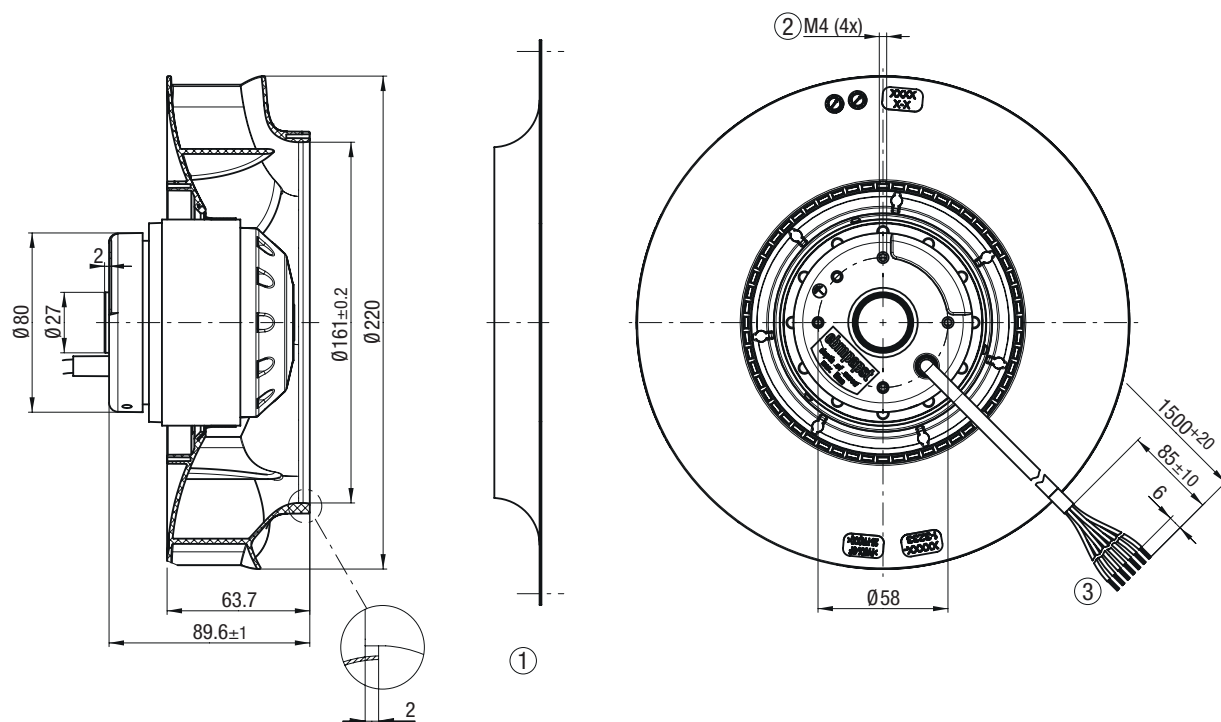

- ① **Accessory part:** Inlet ring 09609-2-4013, not included in scope of delivery  
Dimensions: see "Accessories" chapter
- ② **Max. clearance of screw:** max. 5 mm
- ③ **Cable (halogen-free):** 9x BETAtrans<sup>®</sup> 3 GKW flex, 9G 0.5 mm<sup>2</sup>, 9x crimped splices

**Pin assignment:** see connection diagram



# AC centrifugal fans

backward curved,  $\varnothing$  250 mm



### Material/surface

- Impeller: PA66 plastic, sheet-metal plate painted black
- Rotor: Painted black

### Mechanical data

- Direction of rotation: Clockwise viewed toward rotor
- Mode: Continuous operation (S1)
- Mounting: Maintenance-free ball bearings
- Cable exit: variabel

### Standards and approvals

- Conformity with standards: see page 6
- Approvals: EAC

on Page 116	Drawings
on Page 182	Accessories
on Page 192	Connection diagrams and technical features
on Page 204	Technical parameters & scope
More at	<a href="http://www.ebmpapst.com">www.ebmpapst.com</a>

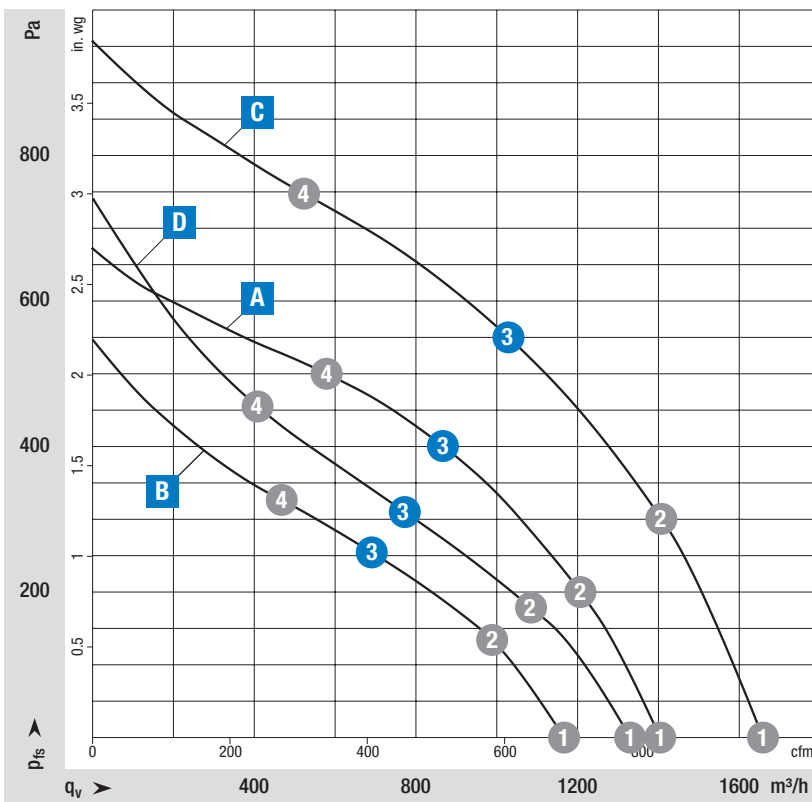

**Measuring requirements**  
 Air performance measured according to: ISO 5801, installation category A, with ebmpapst inlet ring without contact protection.  
 Intake-side sound level:  $L_{wA}$  according to ISO 13347,  $L_{pA}$  measured at 1 m distance from fan axis. The values given are only applicable under the specified measuring conditions and may differ depending on the installation conditions. In the event of deviation from the standard configuration, the parameters must be checked in installed condition.

Curve	Operating point	Nominal voltage	Speed n	Max. Input power P <sub>ed</sub>	Max. Input current I	Sound power level L <sub>WA</sub>	Protection class	Installation position	Perm. ambient temp.	Degree of protection	Insulation class	Conn. diagram
		VDC										
Nominal voltage 400 V AC, 50 Hz												
A	1	400 Δ	2755	174	0,31	78	I	Shaft horizontal or rotor on bottom	-40..+80	IP 44 installation- and position-dependent	F	BA9)
	2	400 Δ	2730	192	0,33	74						
	3	400 Δ	2700	215	0,36	70						
	4	400 Δ	2720	199	0,34	72						
B	1	400 Y	2300	140	0,22	74	I	Shaft horizontal or rotor on bottom	-40..+80	IP 44 installation- and position-dependent	F	BA9)
	2	400 Y	2235	148	0,23	69						
	3	400 Y	2150	160	0,24	64						
	4	400 Y	2200	150	0,24	67						
Nominal voltage 480 V AC, 60 Hz												
C	1	480 Δ	3245	286	0,40	82	I	Shaft horizontal or rotor on bottom	-40..+75	IP 44 installation- and position-dependent	F	BA9)
	2	480 Δ	3195	324	0,44	78						
	3	480 Δ	3150	355	0,48	74						
	4	480 Δ	3215	307	0,42	78						
D	1	480 Y	2600	214	0,29	77	I	Shaft horizontal or rotor on bottom	-40..+75	IP 44 installation- and position-dependent	F	BA9)
	2	480 Y	2475	230	0,31	71						
	3	480 Y	2350	240	0,32	66						
	4	480 Y	2515	222	0,30	72						

Values set in blue are nominal data at operating point with maximum load.

Subject to change

Curve		
	Centrifugal fan	
	Part number	Weight
A	R2D250RC1011	4,70
B		
C		
D		

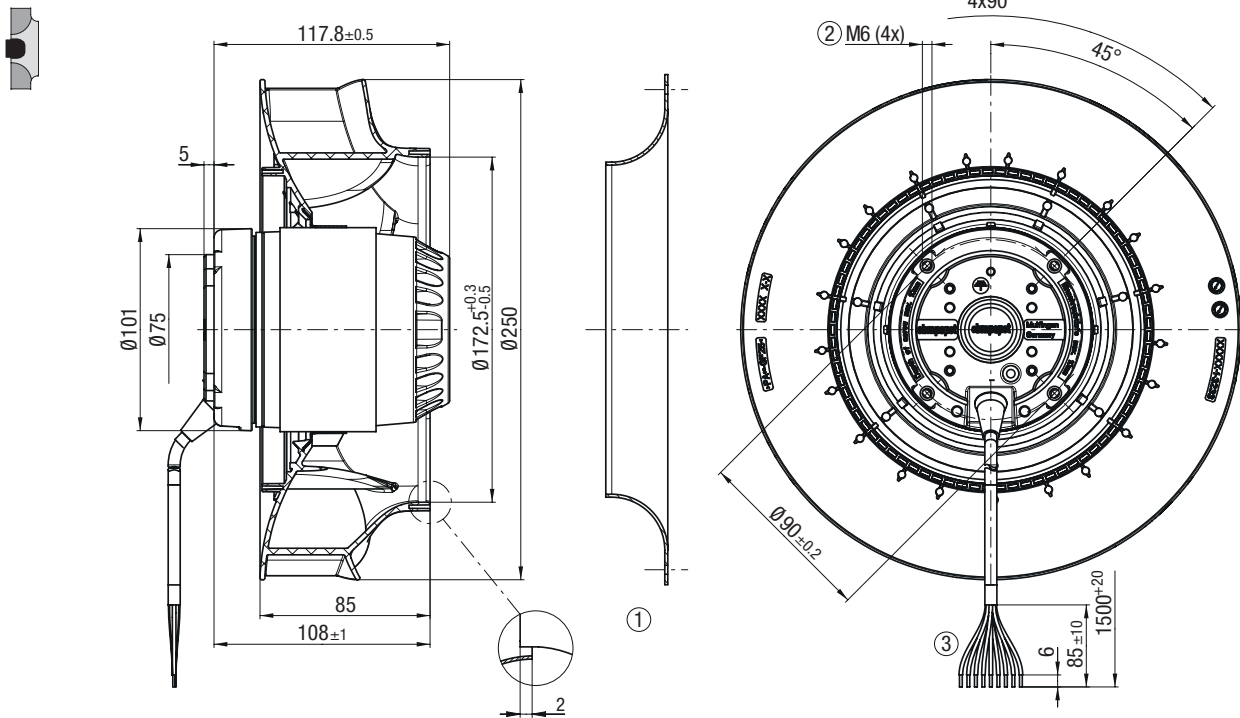

- ① **Accessory part:** Inlet ring 96359-2-4013, not included in scope of delivery  
Dimensions: see "Accessories" chapter
- ② **Max. clearance of screw:** max. 10 mm
- ③ **Cable (halogen-free):** 9x BETrans<sup>®</sup> 3 GW flex, 9G 0.5 mm<sup>2</sup>, 9x crimped splices

**Pin assignment:** see connection diagram





# AC centrifugal fans

backward curved,  $\varnothing 280$  mm



### Material/surface

- Impeller: PA66 plastic, sheet-metal plate painted black
- Rotor: Painted black

### Mechanical data

- Direction of rotation: Clockwise viewed toward rotor
- Mode: Continuous operation (S1)
- Mounting: Maintenance-free ball bearings
- Cable exit: variabel

### Standards and approvals

- Conformity with standards: see page 6
- Approvals: EAC

on Page 120	Drawings
on Page 182	Accessories
on Page 192	Connection diagrams and technical features
on Page 204	Technical parameters & scope
More at	<a href="http://www.ebmpapst.com">www.ebmpapst.com</a>

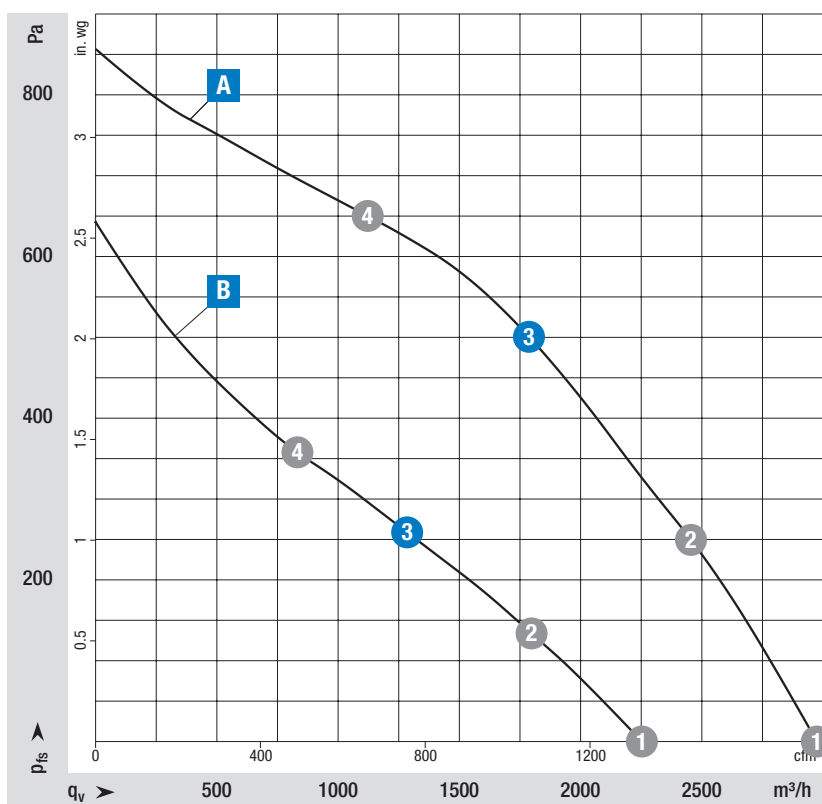

**Measuring requirements**  
 Air performance measured according to: ISO 5801, installation category A, with ebm-papst inlet ring without contact protection.  
 Intake-side sound level:  $L_{pA}$  according to ISO 13347,  $L_{pA}$  measured at 1 m distance from fan axis. The values given are only applicable under the specified measuring conditions and may differ depending on the installation conditions. In the event of deviation from the standard configuration, the parameters must be checked in installed condition.

Curve	Operating point	Nominal voltage	Speed n	Max. Input power $P_{ed}$	Max. Input current I	Sound power level $L_{wA}$	Protection class	Installation position	Perm. ambient temp.	Degree of protection	Insulation class	Conn. diagram
		VDC	rpm	W	A	dB(A)			°C			
Nominal voltage 400 V AC, 50 Hz												
<b>A</b>	1	400 Δ	2635	448	0,76	83	I	Shaft horizontal or rotor on bottom	-40..+60	IP 44 installation- and position-dependent	F	BA9)
	2	400 Δ	2565	509	0,85	78						
	3	400 Δ	2500	535	0,90	73						
	4	400 Δ	2580	480	0,81	76						
<b>B</b>	1	400 Y	2010	300	0,47	76	I	Shaft horizontal or rotor on bottom	-40..+50	IP 44 installation- and position-dependent	F	BA9)
	2	400 Y	1880	322	0,50	70						
	3	400 Y	1800	325	0,50	65						
	4	400 Y	1915	307	0,48	68						

Values set in blue are nominal data at operating point with maximum load.

Subject to change

Curve		
	Centrifugal fan	
	Part number	Weight
<b>A</b>	R2D280RB0811	4,70
<b>B</b>		

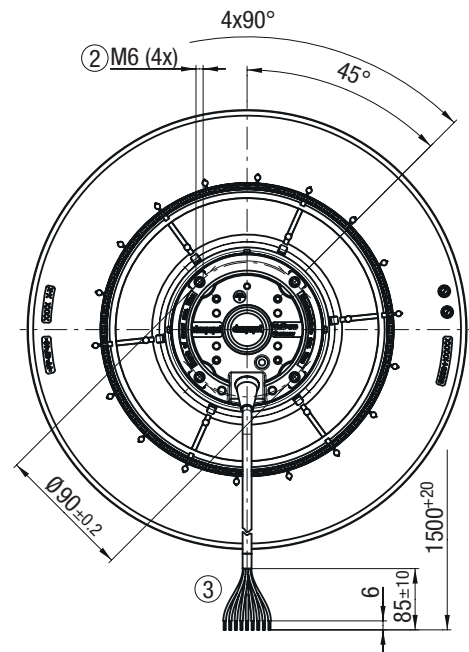
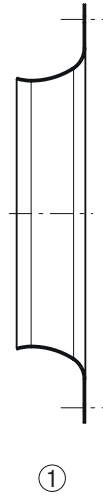
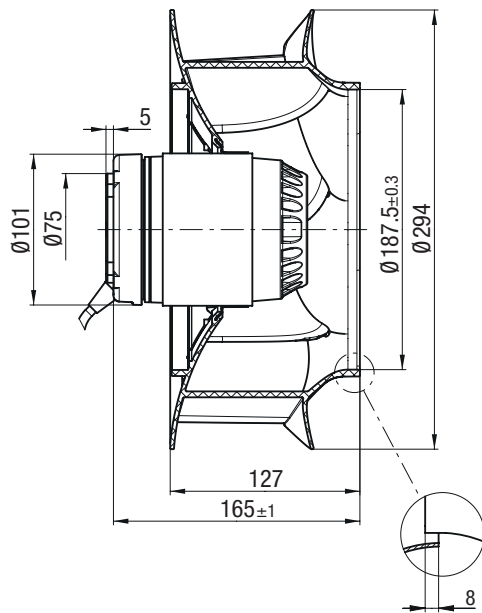

- ① **Accessory part:** Inlet ring 28000-2-4013, not included in scope of delivery  
Dimensions: see "Accessories" chapter
- ② **Max. clearance of screw:** max. 10 mm
- ③ **Cable (halogen-free):** 9x BETAtrans<sup>®</sup> 3 GW flex, 9G 0.5 mm<sup>2</sup>, 9x crimped splices

**Pin assignment:** see connection diagram



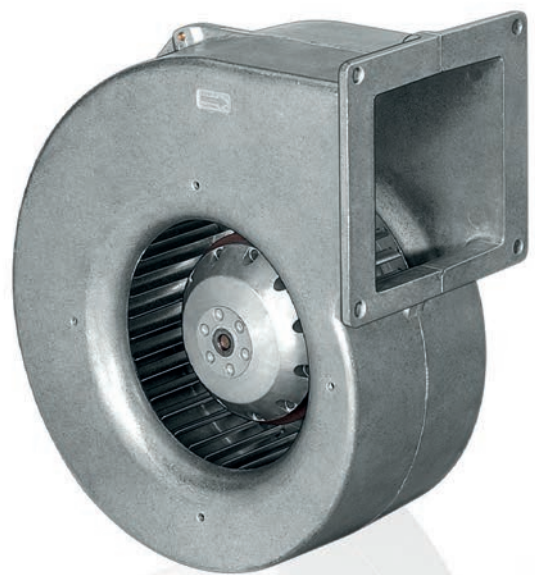

# AC centrifugal fans *vorward curved with housing* Ø 120 - Ø 280, single-intake

**ebmpapst**

the engineer's choice

	Page
Ø 120 (2-pole)	124
Ø 140 (2-pole)	128
Ø 160 (2-pole)	132
Ø 180 (2-pole)	136
Ø 180 (4-pole)	140
Ø 200 (4-pole)	144
Ø 225 (4-pole)	148
Ø 250 (4-pole)	152

# AC centrifugal fans

forward curved with housing, Ø 120 mm



### Material/surface

- Impeller: Sheet steel galvanized
- Housing: Die-cast aluminium
- Rotor: Painted black

### Mechanical data

- Direction of rotation: Clockwise viewed toward rotor
- Mode: Continuous operation (S1)
- Mounting: Maintenance-free ball bearings
- Cable exit: axial

### Standards and approvals

- Conformity with standards: see page 6
- Approvals: EAC

on Page 126	Drawings
on Page 192	Connection diagrams and technical features
on Page 204	Technical parameters & scope
More at	<a href="http://www.ebmpapst.com">www.ebmpapst.com</a>

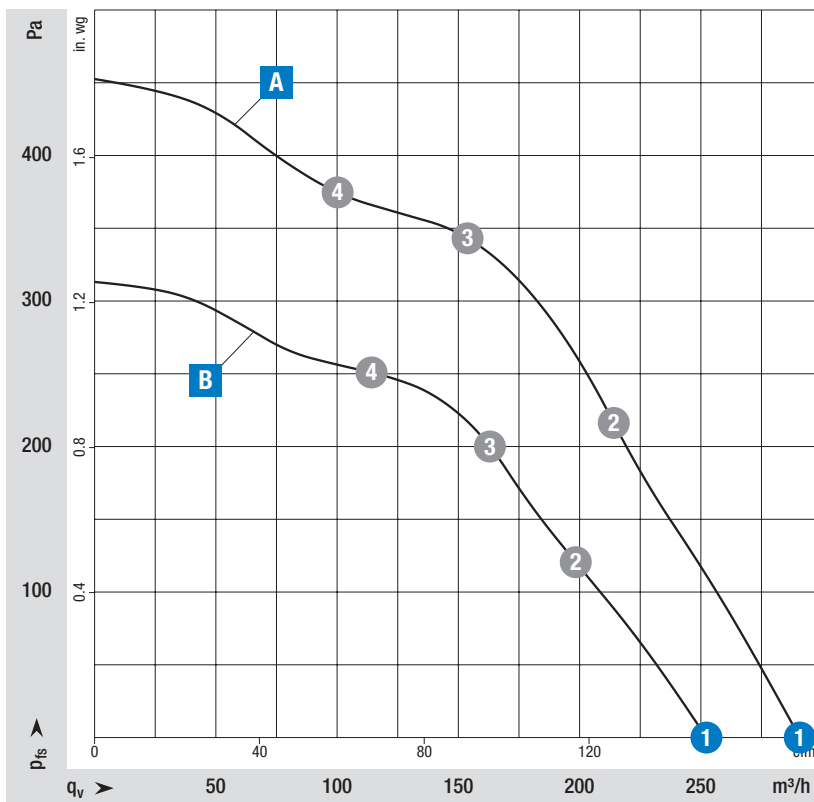

**Measuring requirements**  
 Air performance measured according to: ISO 5801, installation category A, with ebm-papst scroll housing without contact protection.  
 Intake-side sound level:  $L_{pA}$  according to ISO 13347,  $L_{pA}$  measured at 1 m distance from fan axis. The values given are only applicable under the specified measuring conditions and may differ depending on the installation conditions. In the event of deviation from the standard configuration, the parameters must be checked in installed condition.



Curve	Operating point	Nominal voltage	Speed n	Max. Input power $P_{ed}$	Max. Input current I	Sound power level $L_{wA}$	Min. Back pressure	Protection class	Installation position	Perm. ambient temp.	Degree of protection	Insulation class	Conn. diagram
		VDC	rpm	W	A	dB(A)	Pa			°C			
Nominal voltage 400 V AC, 50 Hz													
<b>A</b>	1	400Y	2250	69	0,13	68	0	I	Shaft horizontal or rotor on bottom	-40..+80	IP 44 installation- and position-dependent	F	BA9)
	2	400Y	2440	59	0,12	66							
	3	400Y	2540	53	0,12	66							
	4	400Y	2655	46	0,12	65							
Nominal voltage 480 V AC, 60 Hz													
<b>B</b>	1	480Y	2600	100	0,16	71	0	I	Shaft horizontal or rotor on bottom	-40..+80	IP 44 installation- and position-dependent	F	BA9)
	2	480Y	2905	80	0,13	70							
	3	480Y	3090	66	0,13	70							
	4	480Y	3230	57	0,12	69							

Values set in blue are nominal data at operating point with maximum load.

Subject to change

Curve		
	Centrifugal fan with housing	
	Part number	Weight
<b>A</b>	G2D120AA2203	2,20
<b>B</b>		

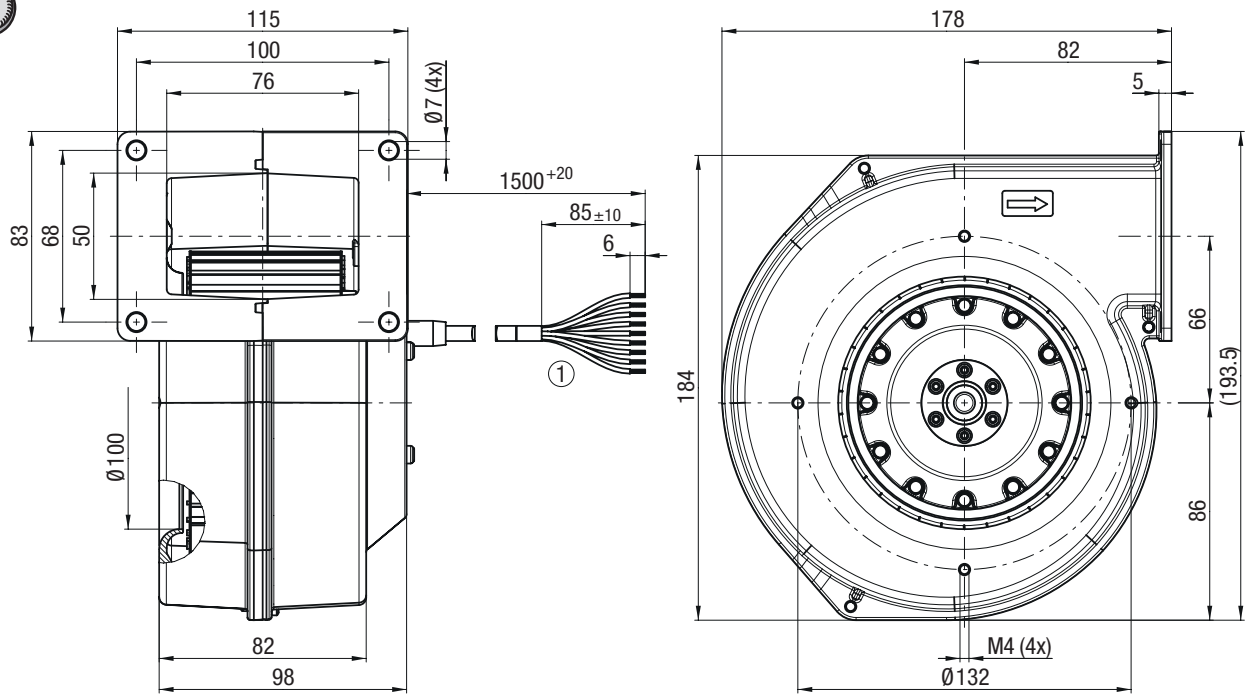

① Cable (halogen-free): BETAtans<sup>®</sup> GKW flex R, 9G 0.5 mm<sup>2</sup>, 9x crimped splices

Pin assignment: see connection diagram



# AC centrifugal fans

forward curved with housing, Ø 140 mm



### Material/surface

- Impeller: Sheet steel galvanized
- Housing: Die-cast aluminium
- Rotor: Painted black

### Mechanical data

- Direction of rotation: Clockwise viewed toward rotor
- Mode: Continuous operation (S1)
- Mounting: Maintenance-free ball bearings
- Cable exit: axial

### Standards and approvals

- Conformity with standards: see page 6
- Approvals: EAC

on Page 130	Drawings
on Page 192	Connection diagrams and technical features
on Page 204	Technical parameters & scope
More at	<a href="http://www.ebmpapst.com">www.ebmpapst.com</a>

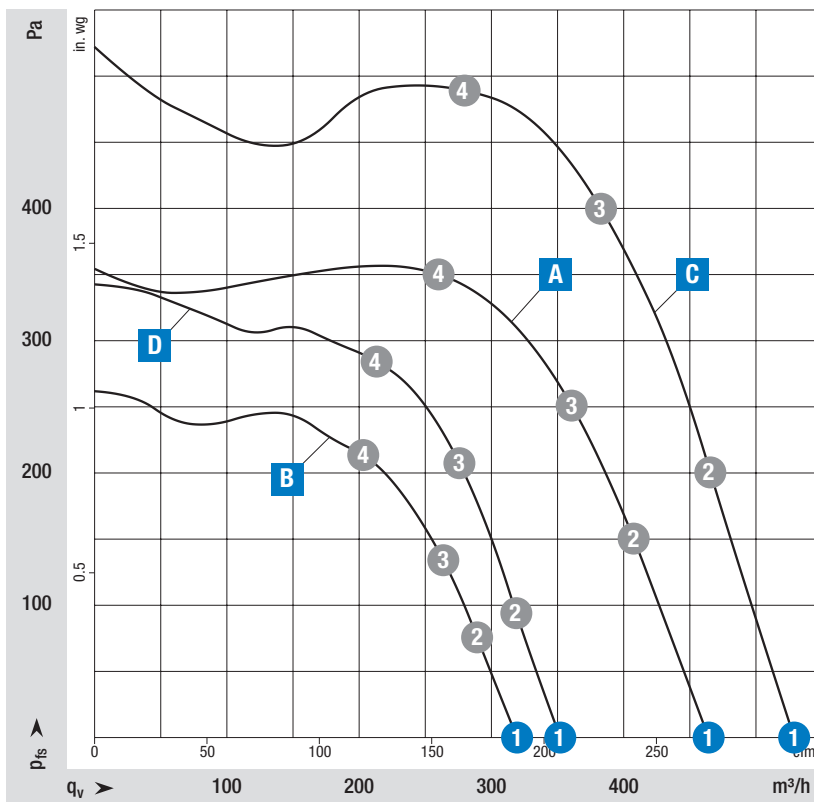

**Measuring requirements**  
 Air performance measured according to: ISO 5801, installation category A, with ebm-papst scroll housing without contact protection.  
 Intake-side sound level: L<sub>A</sub> according to ISO 13347, L<sub>A</sub> measured at 1 m distance from fan axis. The values given are only applicable under the specified measuring conditions and may differ depending on the installation conditions. In the event of deviation from the standard configuration, the parameters must be checked in installed condition.

Curve	Operating point	Nominal voltage	Speed n rpm	Max. Input power $P_{ed}$ W	Max. Input current I A	Sound power level L <sub>WA</sub> dB(A)	Min. Back pressure Pa	Protection class	Installation position	Perm. ambient temp. °C	Degree of protection	Insulation class	Conn. diagram
		VDC											
Nominal voltage 400 V AC, 50 Hz													
A	1	400 Δ	2300	145	0,22	76	0	I	Shaft horizontal or rotor on bottom	-40..+80	IP 44 installation- and position-dependent	F	BA9)
	2	400 Δ	2425	125	0,20	74							
	3	400 Δ	2505	111	0,18	72							
	4	400 Δ	2640	87	0,15	70							
B	1	400 Y	1600	80	0,13	66	0	I	Shaft horizontal or rotor on bottom	-40..+80	IP 44 installation- and position-dependent	F	BA9)
	2	400 Y	1725	76	0,12	65							
	3	400 Y	1835	71	0,11	64							
	4	400 Y	2090	60	0,09	64							
Nominal voltage 480 V AC, 60 Hz													
C	1	480 Δ	2650	225	0,29	79	0	I	Shaft horizontal or rotor on bottom	-40..+80	IP 44 installation- and position-dependent	F	BA9)
	2	480 Δ	2785	198	0,26	77							
	3	480 Δ	2960	166	0,22	75							
	4	480 Δ	3110	134	0,18	74							
D	1	480 Y	1750	120	0,15	68	0	I	Shaft horizontal or rotor on bottom	-40..+80	IP 44 installation- and position-dependent	F	BA9)
	2	480 Y	1925	110	0,14	67							
	3	480 Y	2140	100	0,13	67							
	4	480 Y	2420	87	0,11	68							

Values set in blue are nominal data at operating point with maximum load.

Subject to change

Curve	Centrifugal fan with housing	
	Part number	Weight kg
A	G2D140AC3803	3,50
B		
C		
D		



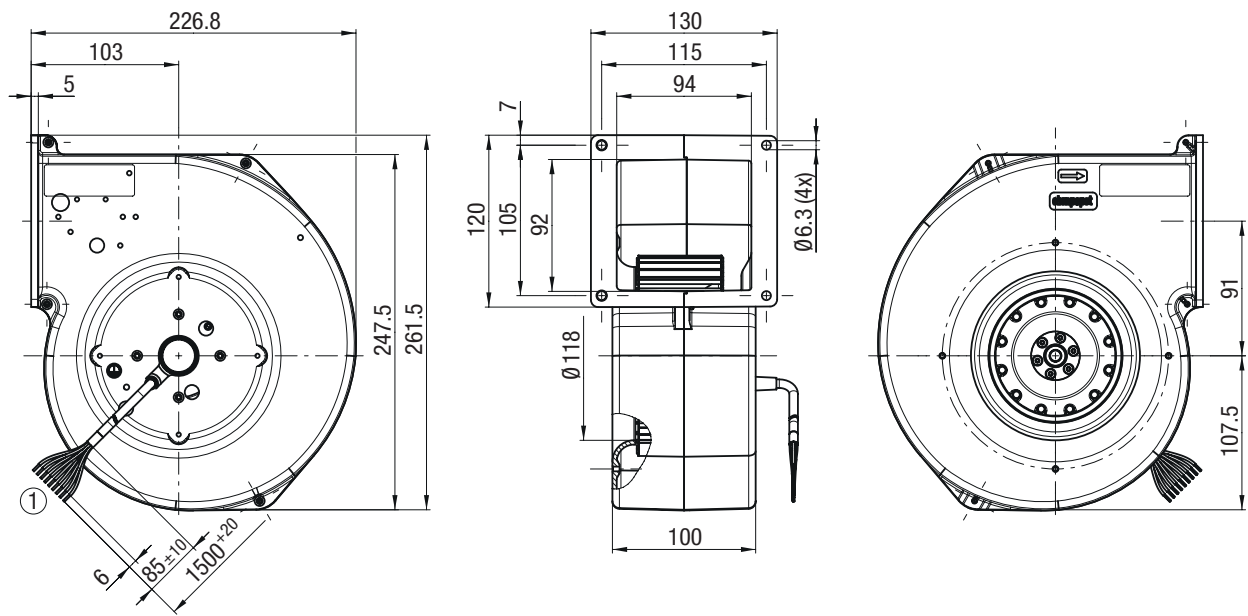

① Cable (halogen-free): BETrans<sup>®</sup> GWK flex R, 9G 0.5 mm<sup>2</sup>, 9x crimped splices

Pin assignment: see connection diagram



# AC centrifugal fans

forward curved with housing, Ø 160 mm



### Material/surface

- Impeller: Sheet steel galvanized
- Housing: Die-cast aluminium
- Rotor: Painted black

### Mechanical data

- Direction of rotation: Clockwise viewed toward rotor
- Mode: Continuous operation (S1)
- Mounting: Maintenance-free ball bearings
- Cable exit: axial

### Standards and approvals

- Conformity with standards: see page 6
- Approvals: EAC

on Page 134	Drawings
on Page 192	Connection diagrams and technical features
on Page 204	Technical parameters & scope
More at	<a href="http://www.ebmpapst.com">www.ebmpapst.com</a>

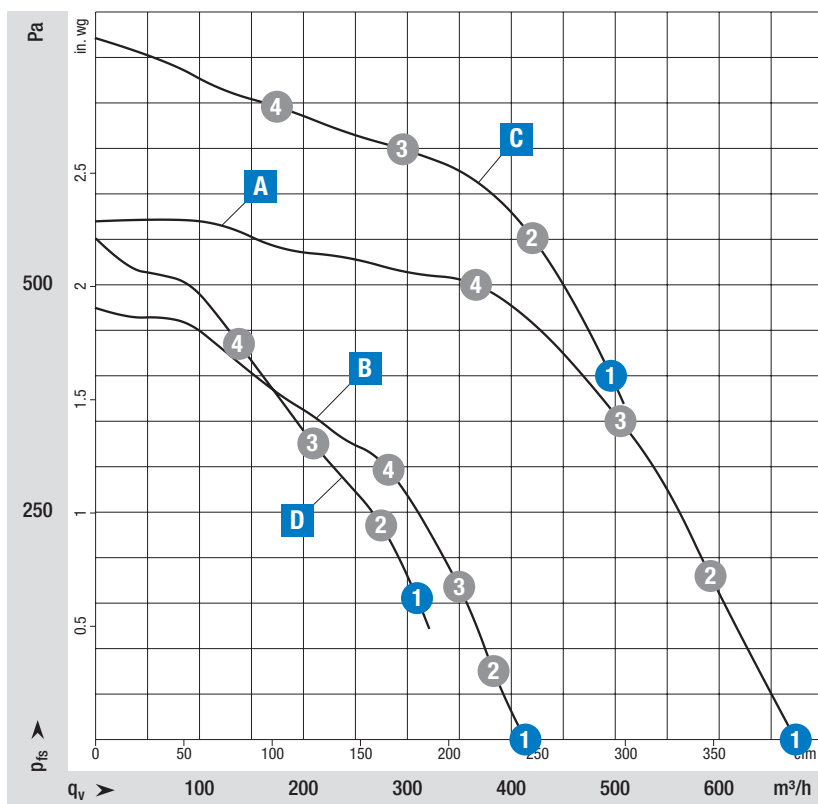

#### Measuring requirements

Air performance measured according to: ISO 5801, installation category A, with ebmpapst scroll housing without contact protection. Intake-side sound level:  $L_{wA}$  according to ISO 13347,  $L_{pA}$  measured at 1 m distance from fan axis. The values given are only applicable under the specified measuring conditions and may differ depending on the installation conditions. In the event of deviation from the standard configuration, the parameters must be checked in installed condition.



Curve	Operating point	Nominal voltage	Speed n	Max. Input power $P_{ed}$	Max. Input current I	Sound power level $L_{wA}$	Min. Back pressure	Protection class	Installation position	Perm. ambient temp.	Degree of protection	Insulation class	Conn. diagram
		VDC											
Nominal voltage 400 V AC, 50 Hz													
A	1	400 $\Delta$	2200	320	0,48	80	0	I	Shaft horizontal or rotor on bottom	-40..+55	IP 44 installation- and position-dependent	F	BA9)
	2	400 $\Delta$	2355	269	0,41	78							
	3	400 $\Delta$	2510	221	0,34	76							
	4	400 $\Delta$	2680	160	0,27	74							
B	1	400 Y	1350	160	0,24	67	0	I	Shaft horizontal or rotor on bottom	-40..+55	IP 44 installation- and position-dependent	F	BA9)
	2	400 Y	1555	150	0,23	67							
	3	400 Y	1765	137	0,21	67							
	4	400 Y	2075	115	0,18	67							
Nominal voltage 400 V AC, 60 Hz													
C	1	400 $\Delta$	2600	305	0,46	76	400	I	Shaft horizontal or rotor on bottom	-40..+50	IP 44 installation- and position-dependent	F	BA9)
	2	400 $\Delta$	2840	254	0,39	76							
	3	400 $\Delta$	3105	187	0,29	78							
	4	400 $\Delta$	3150	179	0,28	79							
D	1	400 Y	1650	155	0,24	64	155	I	Shaft horizontal or rotor on bottom	-40..+50	IP 44 installation- and position-dependent	F	BA9)
	2	400 Y	1875	144	0,22	65							
	3	400 Y	2180	129	0,20	69							
	4	400 Y	2535	109	0,17	73							

Values set in blue are nominal data at operating point with maximum load.

Subject to change

Curve	Centrifugal fan with housing	
	Part number	Weight kg
A	G2D160AF1203	4,00
B		
C		
D		



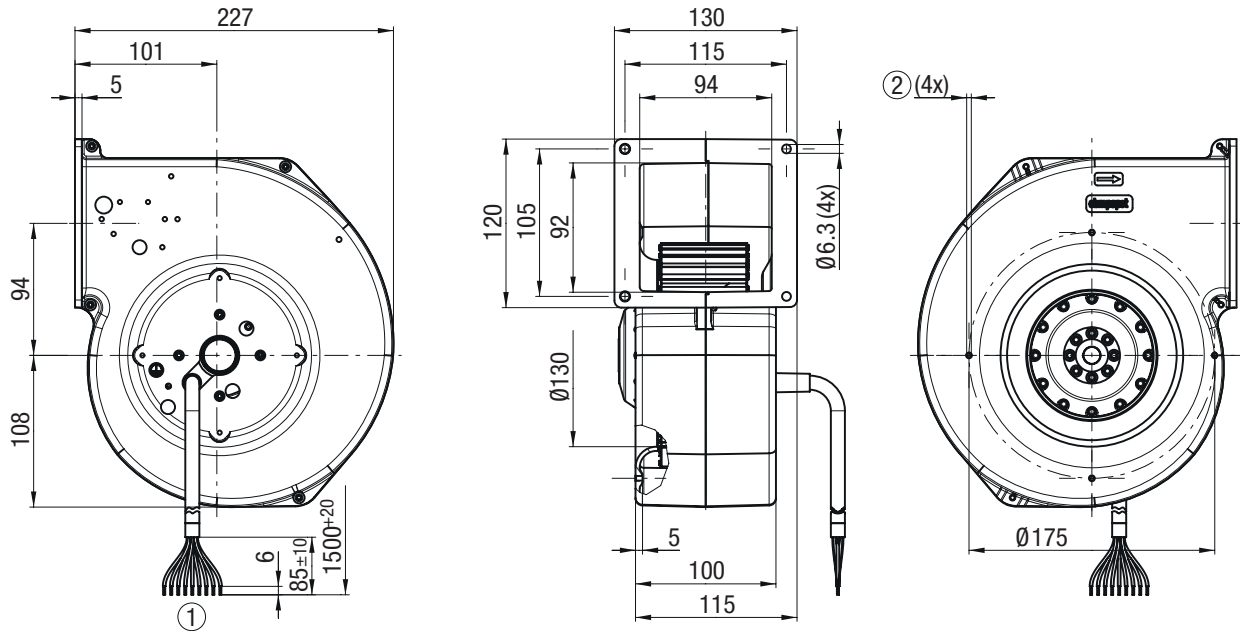

- ① Cable (halogen-free): BETAtans<sup>®</sup> GKW flex R, 9G 0.5 mm<sup>2</sup>, 9x crimped splices
- ② For self-tapping M<sub>4</sub> screws

Pin assignment: see connection diagram



# AC centrifugal fans

forward curved with housing, Ø 180 mm



### Material/surface

- Impeller: Sheet steel galvanized
- Housing: Die-cast aluminium
- Rotor: Painted black

### Mechanical data

- Direction of rotation: Clockwise viewed toward rotor
- Mode: Continuous operation (S1)
- Mounting: Maintenance-free ball bearings
- Cable exit: axial

### Standards and approvals

- Conformity with standards: see page 6
- Approvals: EAC

on Page 138	Drawings
on Page 192	Connection diagrams and technical features
on Page 204	Technical parameters & scope
More at	<a href="http://www.ebmpapst.com">www.ebmpapst.com</a>

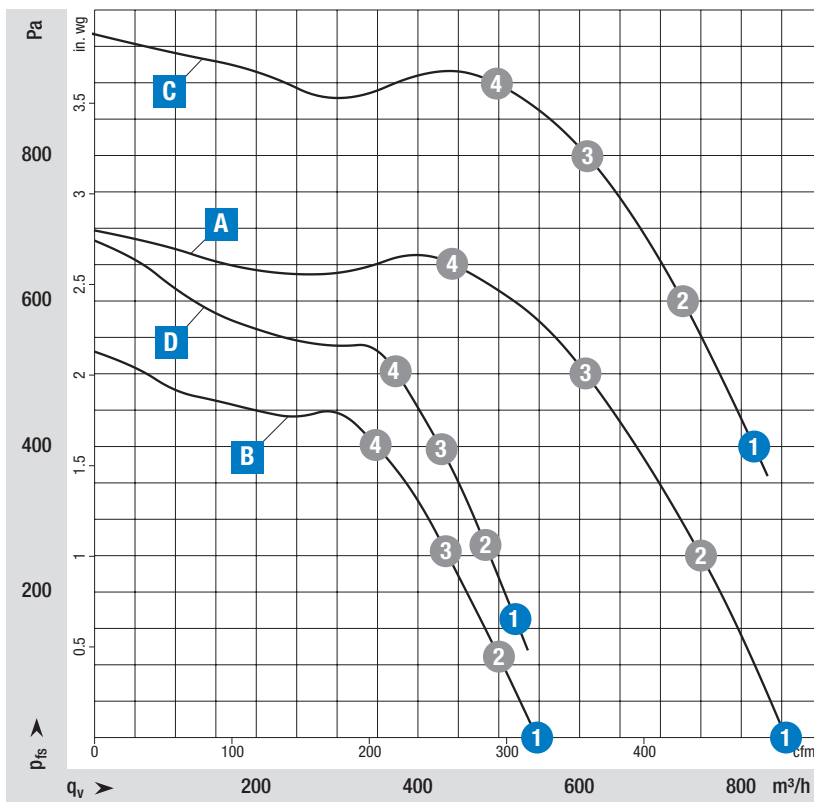

**Measuring requirements**  
 Air performance measured according to: ISO 5801, installation category A, with ebm-papst scroll housing without contact protection. Intake-side sound level:  $L_{pA}$  according to ISO 13347,  $L_{pA}$  measured at 1 m distance from fan axis. The values given are only applicable under the specified measuring conditions and may differ depending on the installation conditions. In the event of deviation from the standard configuration, the parameters must be checked in installed condition.

Curve	Operating point	Nominal voltage	Speed n	Max. Input power $P_{ed}$	Max. Input current I	Sound power level $L_{wA}$	Min. Back pressure	Protection class	Installation position	Perm. ambient temp.	Degree of protection	Insulation class	Conn. diagram
		VDC											
Nominal voltage 400 V AC, 50 Hz													
A	1	400 $\Delta$	2150	450	0,70	83	0	I	Shaft horizontal or rotor on bottom	-40..+70	IP 44 installation- and position-dependent	F	BA9)
	2	400 $\Delta$	2340	384	0,60	81							
	3	400 $\Delta$	2515	301	0,48	78							
	4	400 $\Delta$	2665	226	0,38	76							
B	1	400 Y	1400	240	0,37	71	0	I	Shaft horizontal or rotor on bottom	-40..+70	IP 44 installation- and position-dependent	F	BA9)
	2	400 Y	1585	222	0,36	70							
	3	400 Y	1825	197	0,31	70							
	4	400 Y	2110	163	0,26	70							
Nominal voltage 480 V AC, 60 Hz													
C	1	480 $\Delta$	2700	580	0,75	83	400	I	Shaft horizontal or rotor on bottom	-40..+45	IP 44 installation- and position-dependent	F	BA9)
	2	480 $\Delta$	2850	510	0,67	82							
	3	480 $\Delta$	3015	423	0,56	81							
	4	480 $\Delta$	3130	357	0,48	80							
D	1	480 Y	1750	300	0,40	72	160	I	Shaft horizontal or rotor on bottom	-40..+45	IP 44 installation- and position-dependent	F	BA9)
	2	480 Y	1925	285	0,38	72							
	3	480 Y	2140	263	0,35	72							
	4	480 Y	2355	239	0,32	73							

Values set in blue are nominal data at operating point with maximum load.

Subject to change

Curve	Centrifugal fan with housing	
	Part number	Weight kg
A	G2D180AB1003	5,40
B		
C		
D		



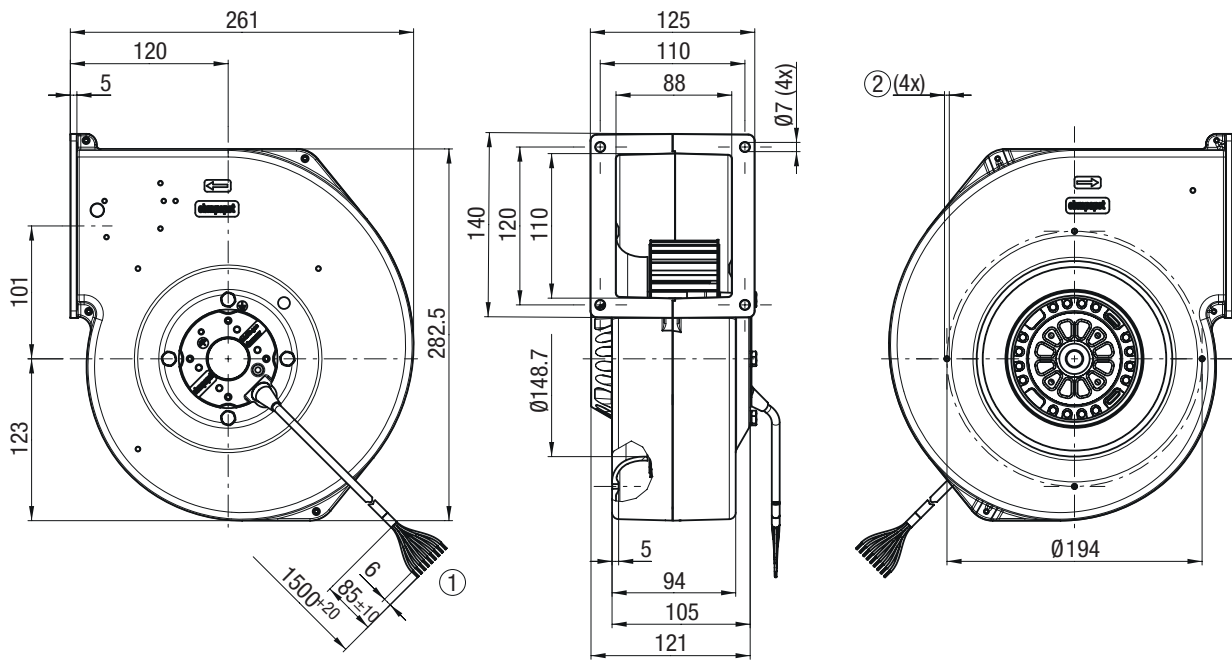

- ① Cable (halogen-free): BETAtrans<sup>®</sup> GKW flex R, 9G 0.5 mm<sup>2</sup>, 9x crimped splices
- ② For self-tapping M4 screws

Pin assignment: see connection diagram



# AC centrifugal fans

forward curved with housing, Ø 180 mm



### Material/surface

- Impeller: Sheet steel galvanized
- Housing: Sheet steel galvanized
- Rotor: Painted black

### Mechanical data

- Direction of rotation: Clockwise viewed toward rotor
- Mode: Continuous operation (S1)
- Mounting: Maintenance-free ball bearings
- Cable exit: variabel

### Standards and approvals

- Conformity with standards: see page 6
- Approvals: EAC

on Page 142	Drawings
on Page 192	Connection diagrams and technical features
on Page 204	Technical parameters & scope
More at	<a href="http://www.ebmpapst.com">www.ebmpapst.com</a>

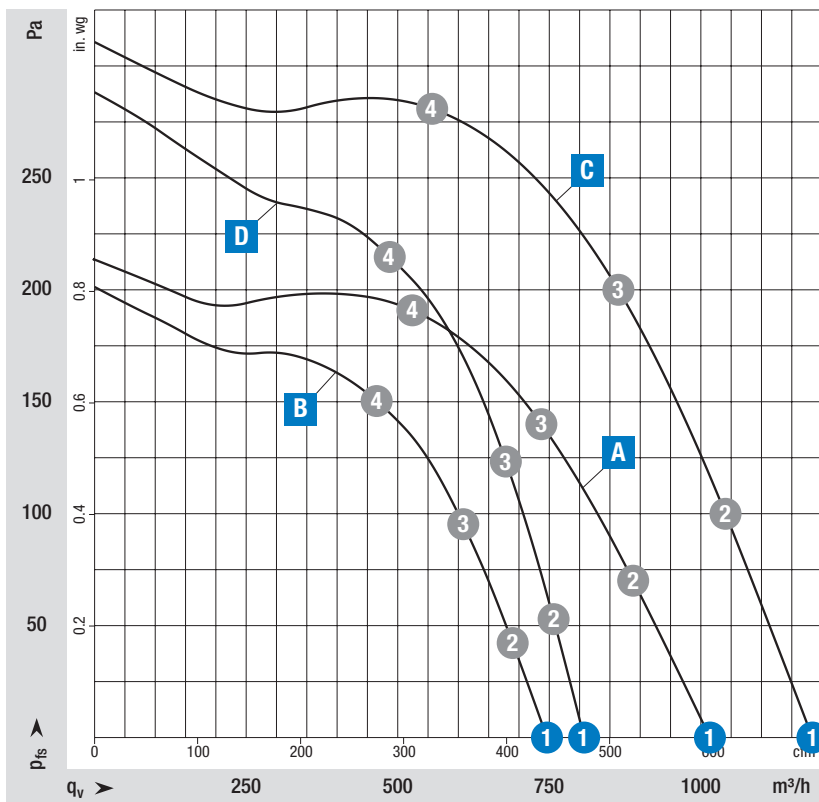

**Measuring requirements**  
 Air performance measured according to: ISO 5801, installation category A, with ebm-papst scroll housing without contact protection.  
 Intake-side sound level:  $L_{pA}$  according to ISO 13347,  $L_{pA}$  measured at 1 m distance from fan axis. The values given are only applicable under the specified measuring conditions and may differ depending on the installation conditions. In the event of deviation from the standard configuration, the parameters must be checked in installed condition.



Curve	Operating point	Nominal voltage	Speed n	Max. Input power $P_{ed}$	Max. Input current I	Sound power level $L_{WA}$	Min. Back pressure	Protection class	Installation position	Perm. ambient temp.	Degree of protection	Insulation class	Conn. diagram
		VDC											
Nominal voltage 400 V AC, 50 Hz													
A	1	400 $\Delta$	1300	190	0,40	72	0	I	Shaft horizontal or rotor on bottom	-40...+65	IP 44 installation- and position-dependent	F	BA9)
	2	400 $\Delta$	1350	162	0,34	70							
	3	400 $\Delta$	1385	136	0,32	67							
	4	400 $\Delta$	1425	106	0,31	64							
B	1	400 Y	970	120	0,21	65	0	I	Shaft horizontal or rotor on bottom	-40...+85	IP 44 installation- and position-dependent	F	BA9)
	2	400 Y	1050	107	0,19	63							
	3	400 Y	1145	93	0,16	62							
	4	400 Y	1265	71	0,13	61							
Nominal voltage 480 V AC, 60 Hz													
C	1	480 $\Delta$	1500	300	0,47	76	0	I	Shaft horizontal or rotor on bottom	-40...+50	IP 44 installation- and position-dependent	F	BA9)
	2	480 $\Delta$	1580	253	0,40	74							
	3	480 $\Delta$	1635	207	0,36	71							
	4	480 $\Delta$	1705	145	0,32	68							
D	1	480 Y	1050	165	0,25	67	0	I	Shaft horizontal or rotor on bottom	-40...+60	IP 44 installation- and position-dependent	F	BA9)
	2	480 Y	1160	155	0,23	66							
	3	480 Y	1290	137	0,20	65							
	4	480 Y	1495	101	0,15	65							

Values set in blue are nominal data at operating point with maximum load.

Subject to change

Curve	Centrifugal fan with housing	
	Part number	Weight kg
A	G4D180FF2402	6,00
B		
C		
D		



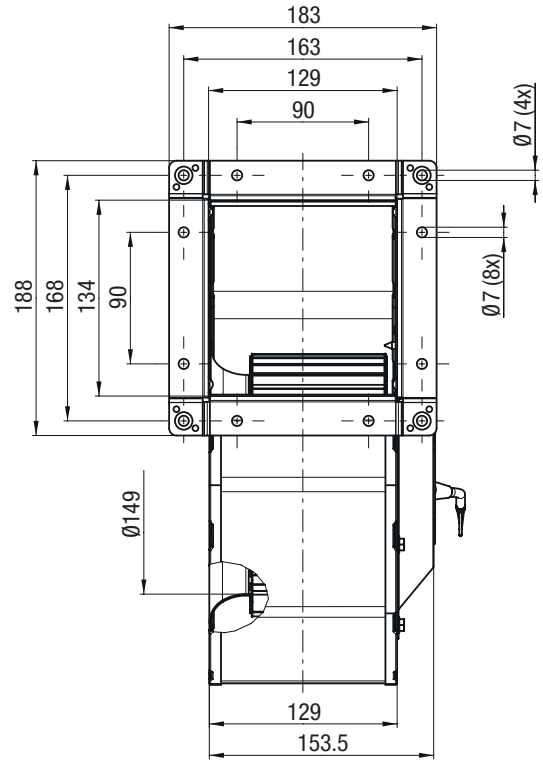
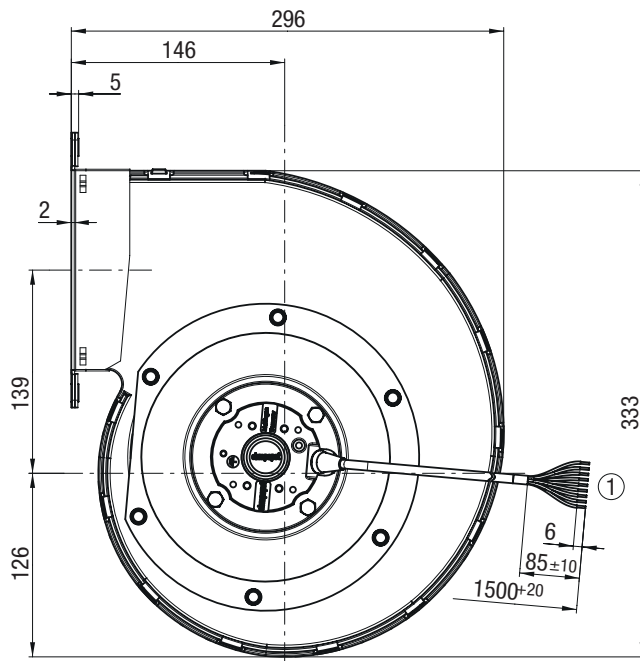

① Cable (halogen-free): BETAtans<sup>®</sup> 3 GKW flex, 9G 0.75 mm<sup>2</sup>, 9x crimped splices

Pin assignment: see connection diagram



# AC centrifugal fans

forward curved with housing, Ø 200 mm



### Material/surface

- Impeller: Sheet steel galvanized
- Housing: Sheet steel galvanized
- Rotor: Painted black

### Mechanical data

- Direction of rotation: Clockwise viewed toward rotor
- Mode: Continuous operation (S1)
- Mounting: Maintenance-free ball bearings
- Cable exit: variabel

### Standards and approvals

- Conformity with standards: see page 6
- Approvals: EAC

on Page 146	Drawings
on Page 192	Connection diagrams and technical features
on Page 204	Technical parameters & scope
More at	<a href="http://www.ebmpapst.com">www.ebmpapst.com</a>

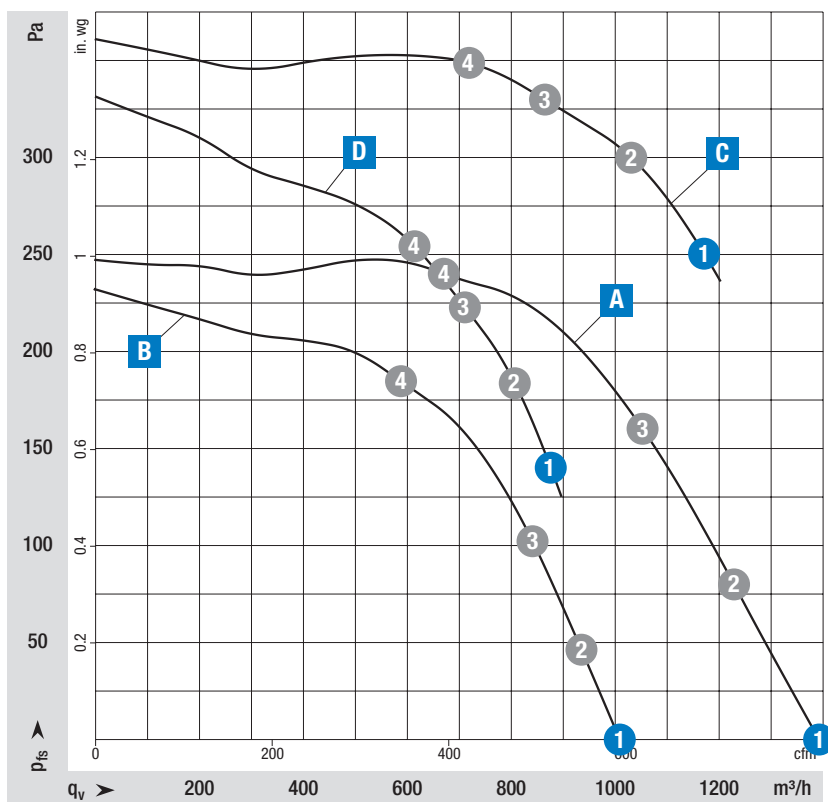

#### Measuring requirements

Air performance measured according to: ISO 5801, installation category A, with ebm-papst scroll housing without contact protection. Intake-side sound level:  $L_{pA}$  according to ISO 13347,  $L_{pA}$  measured at 1 m distance from fan axis. The values given are only applicable under the specified measuring conditions and may differ depending on the installation conditions. In the event of deviation from the standard configuration, the parameters must be checked in installed condition.

Curve	Operating point	Nominal voltage	Speed n	Max. Input power $P_{ed}$	Max. Input current I	Sound power level $L_{wA}$	Min. Back pressure	Protection class	Installation position	Perm. ambient temp.	Degree of protection	Insulation class	Conn. diagram
		VDC											
Nominal voltage 400 V AC, 50 Hz													
A	1	400 $\Delta$	1250	300	0,55	74	0	I	Shaft horizontal or rotor on bottom	-40...+65	IP 44 installation- and position-dependent	F	BA9)
	2	400 $\Delta$	1325	253	0,48	72							
	3	400 $\Delta$	1360	215	0,44	70							
	4	400 $\Delta$	1415	149	0,39	67							
B	1	400Y	950	185	0,31	67	0	I	Shaft horizontal or rotor on bottom	-40...+65	IP 44 installation- and position-dependent	F	BA9)
	2	400Y	1010	168	0,28	65							
	3	400Y	1090	152	0,25	65							
	4	400Y	1250	109	0,19	64							
Nominal voltage 480 V AC, 60 Hz													
C	1	480 $\Delta$	1600	325	0,55	74	250	I	Shaft horizontal or rotor on bottom	-40...+60	IP 44 installation- and position-dependent	F	BA9)
	2	480 $\Delta$	1635	288	0,47	73							
	3	480 $\Delta$	1665	246	0,44	72							
	4	480 $\Delta$	1690	213	0,41	71							
D	1	480Y	1200	220	0,31	66	140	I	Shaft horizontal or rotor on bottom	-40...+60	IP 44 installation- and position-dependent	F	BA9)
	2	480Y	1290	200	0,28	67							
	3	480Y	1375	180	0,25	67							
	4	480Y	1445	160	0,23	67							

Values set in blue are nominal data at operating point with maximum load.

Subject to change

Curve	Centrifugal fan with housing	
	Part number	Weight kg
A	G4D200BL1903	7,30
B		
C		
D		



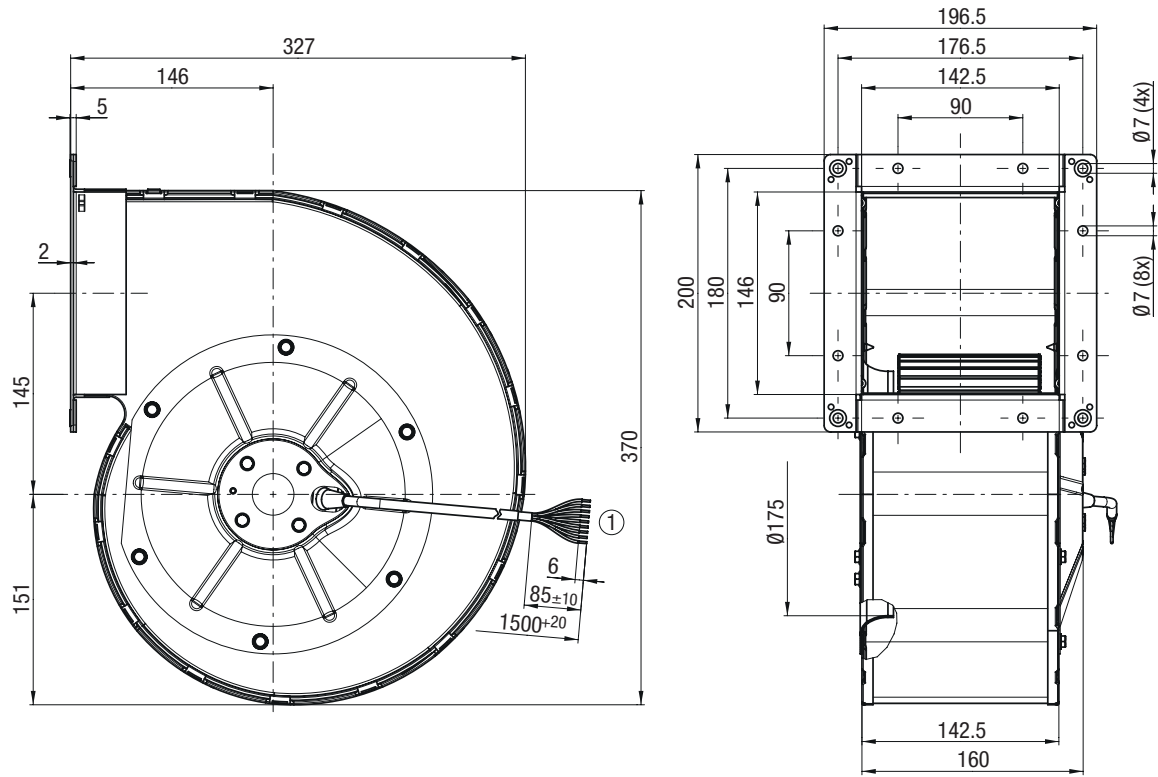

① Cable (halogen-free): BETAtrans® 3 GKW flex, 9G 0.75 mm<sup>2</sup>, 9x crimped splices

Pin assignment: see connection diagram



# AC centrifugal fans

forward curved with housing, Ø 225 mm



### Material/surface

- Impeller: Sheet steel galvanized
- Housing: Sheet steel galvanized
- Rotor: Painted black

### Mechanical data

- Direction of rotation: Clockwise viewed toward rotor
- Mode: Continuous operation (S1)
- Mounting: Maintenance-free ball bearings
- Cable exit: variabel

### Standards and approvals

- Conformity with standards: see page 6
- Approvals: EAC

on Page 150	Drawings
on Page 192	Connection diagrams and technical features
on Page 204	Technical parameters & scope
More at	<a href="http://www.ebmpapst.com">www.ebmpapst.com</a>

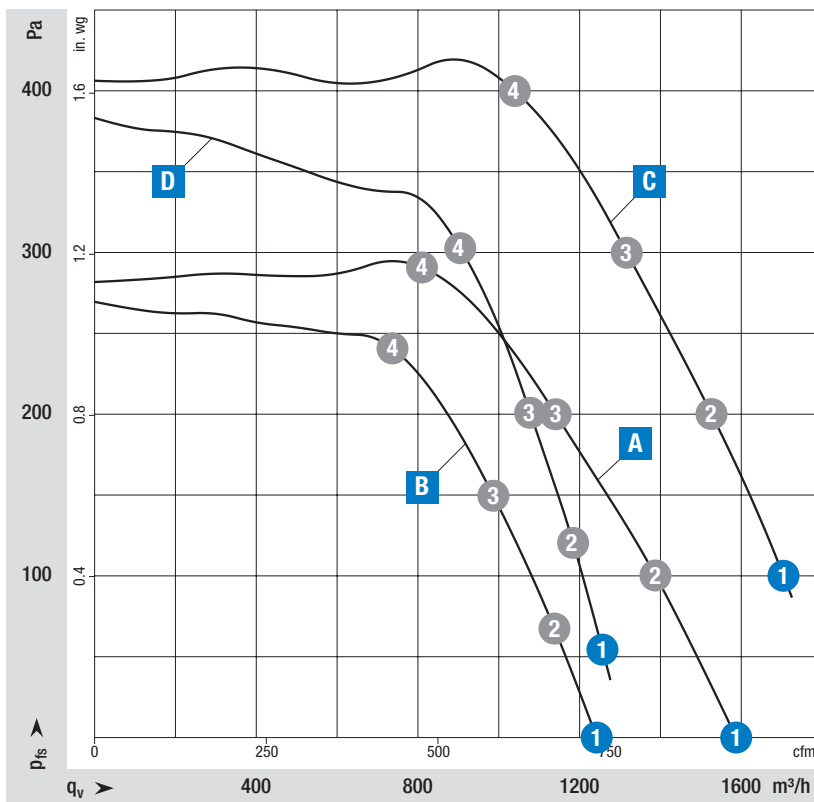

#### Measuring requirements

Air performance measured according to: ISO 5801, installation category A, with ebm-papst scroll housing without contact protection. Intake-side sound level:  $L_{pA}$  according to ISO 13347,  $L_{pA}$  measured at 1 m distance from fan axis. The values given are only applicable under the specified measuring conditions and may differ depending on the installation conditions. In the event of deviation from the standard configuration, the parameters must be checked in installed condition.



Curve	Operating point	Nominal voltage	Speed n	Max. Input power P <sub>ed</sub>	Max. Input current I	Sound power level L <sub>WA</sub>	Min. Back pressure	Protection class	Installation position	Perm. ambient temp.	Degree of protection	Insulation class	Conn. diagram
		VDC											
Nominal voltage 400 V AC, 50 Hz													
A	1	400Δ	1350	405	0,80	80	0	I	Shaft horizontal or rotor on bottom	-40..+80	IP 54	F	BA9)
	2	400Δ	1375	347	0,70	77							
	3	400Δ	1405	281	0,63	75							
	4	400Δ	1435	207	0,57	71							
B	1	400Y	1050	300	0,50	73	0	I	Shaft horizontal or rotor on bottom	-40..+80	IP 54	F	BA9)
	2	400Y	1130	266	0,47	73							
	3	400Y	1215	224	0,39	71							
	4	400Y	1310	167	0,30	69							
Nominal voltage 480 V AC, 60 Hz													
C	1	480Δ	1600	600	0,90	82	100	I	Shaft horizontal or rotor on bottom	-40..+50	IP 54	F	BA9)
	2	480Δ	1640	512	0,81	80							
	3	480Δ	1670	436	0,72	79							
	4	480Δ	1700	346	0,64	76							
D	1	480Y	1200	410	0,60	74	55	I	Shaft horizontal or rotor on bottom	-40..+50	IP 54	F	BA9)
	2	480Y	1285	379	0,56	74							
	3	480Y	1370	341	0,50	73							
	4	480Y	1485	280	0,41	73							

Values set in blue are nominal data at operating point with maximum load.

Subject to change

Curve		
	Centrifugal fan with housing	
	Part number	Weight
A	G4D225FK2002	9,50
B		
C		
D		

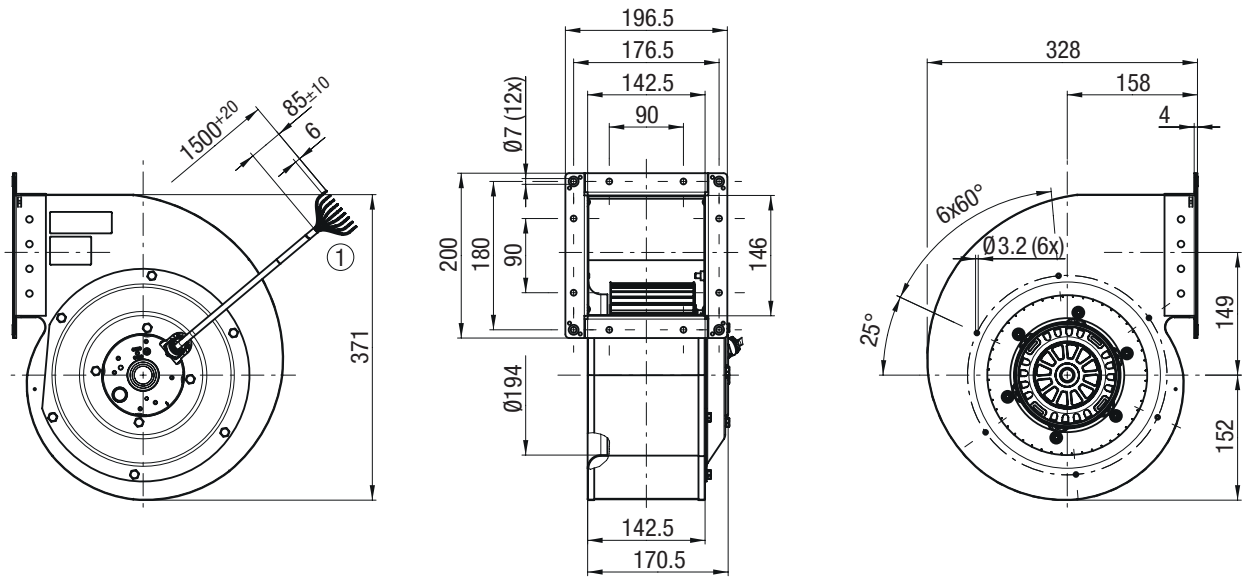

① Cable (halogen-free): BETAtans<sup>®</sup> 3 GKW flex, 9G 0.75 mm<sup>2</sup>, 9x crimped splices

Pin assignment: see connection diagram



# AC centrifugal fans

forward curved with housing, Ø 250 mm



### Material/surface

- Impeller: Sheet steel galvanized
- Housing: Sheet steel galvanized
- Rotor: Painted black

### Mechanical data

- Direction of rotation: Clockwise viewed toward rotor
- Mode: Continuous operation (S1)
- Mounting: Maintenance-free ball bearings
- Cable exit: variabel

### Standards and approvals

- Conformity with standards: see page 6
- Approvals: EAC

on Page 154	Drawings
on Page 192	Connection diagrams and technical features
on Page 204	Technical parameters & scope
More at	<a href="http://www.ebmpapst.com">www.ebmpapst.com</a>

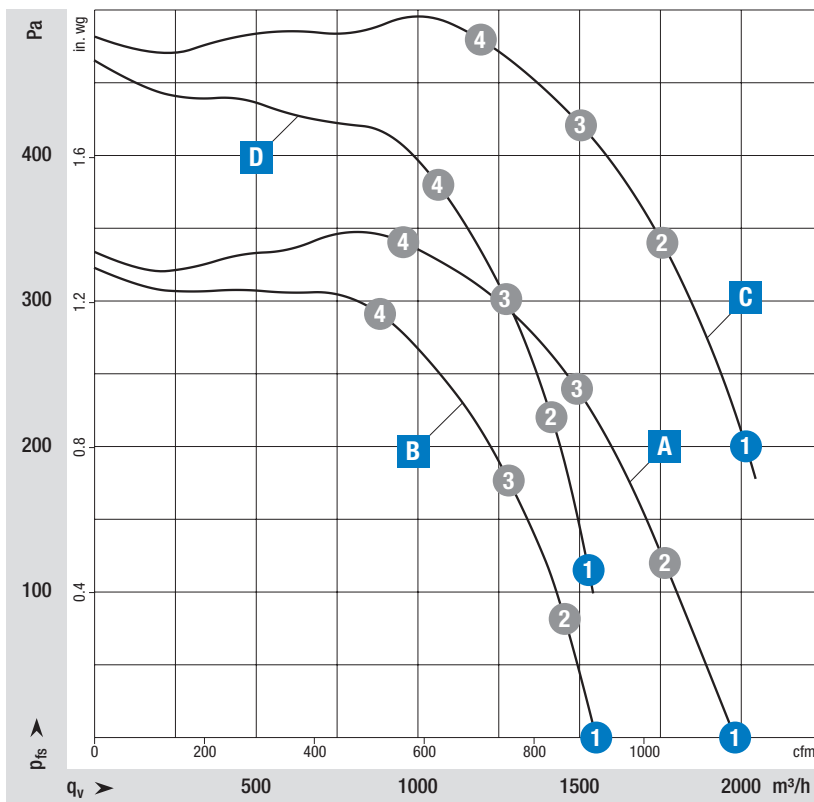

#### Measuring requirements

Air performance measured according to: ISO 5801, installation category A, with ebm-papst scroll housing without contact protection. Intake-side sound level:  $L_{pA}$  according to ISO 13347,  $L_{pA}$  measured at 1 m distance from fan axis. The values given are only applicable under the specified measuring conditions and may differ depending on the installation conditions. In the event of deviation from the standard configuration, the parameters must be checked in installed condition.

Curve	Operating point	Nominal voltage	Speed n rpm	Max. Input power P <sub>ed</sub> W	Max. Input current I A	Sound power level L <sub>WA</sub> dB(A)	Min. Back pressure Pa	Protection class	Installation position	Perm. ambient temp. °C	Degree of protection	Insulation class	Conn. diagram
		VDC											
Nominal voltage 400 V AC, 50 Hz													
A	1	400 Δ	1340	575	1,10	82	0	I	Shaft horizontal or rotor on bottom	-40..+70	IP 54	F	BA9)
	2	400 Δ	1375	482	0,98	80							
	3	400 Δ	1405	386	0,87	76							
	4	400 Δ	1445	248	0,75	72							
B	1	400 Y	1050	410	0,70	76	0	I	Shaft horizontal or rotor on bottom	-40..+70	IP 54	F	BA9)
	2	400 Y	1135	359	0,63	75							
	3	400 Y	1215	306	0,54	73							
	4	400 Y	1340	200	0,37	70							
Nominal voltage 480 V AC, 60 Hz													
C	1	480 Δ	1620	770	1,20	83	200	I	Shaft horizontal or rotor on bottom	-40..+50	IP 54	F	BA9)
	2	480 Δ	1660	628	1,03	80							
	3	480 Δ	1685	523	0,93	78							
	4	480 Δ	1715	411	0,82	76							
D	1	480 Y	1230	535	0,80	76	115	I	Shaft horizontal or rotor on bottom	-40..+50	IP 54	F	BA9)
	2	480 Y	1350	474	0,70	75							
	3	480 Y	1440	415	0,61	74							
	4	480 Y	1535	338	0,50	73							

Values set in blue are nominal data at operating point with maximum load.

Subject to change

Curve		
	Centrifugal fan with housing	
	Part number	Weight kg
A	G4D250DC1402	13,50
B		
C		
D		

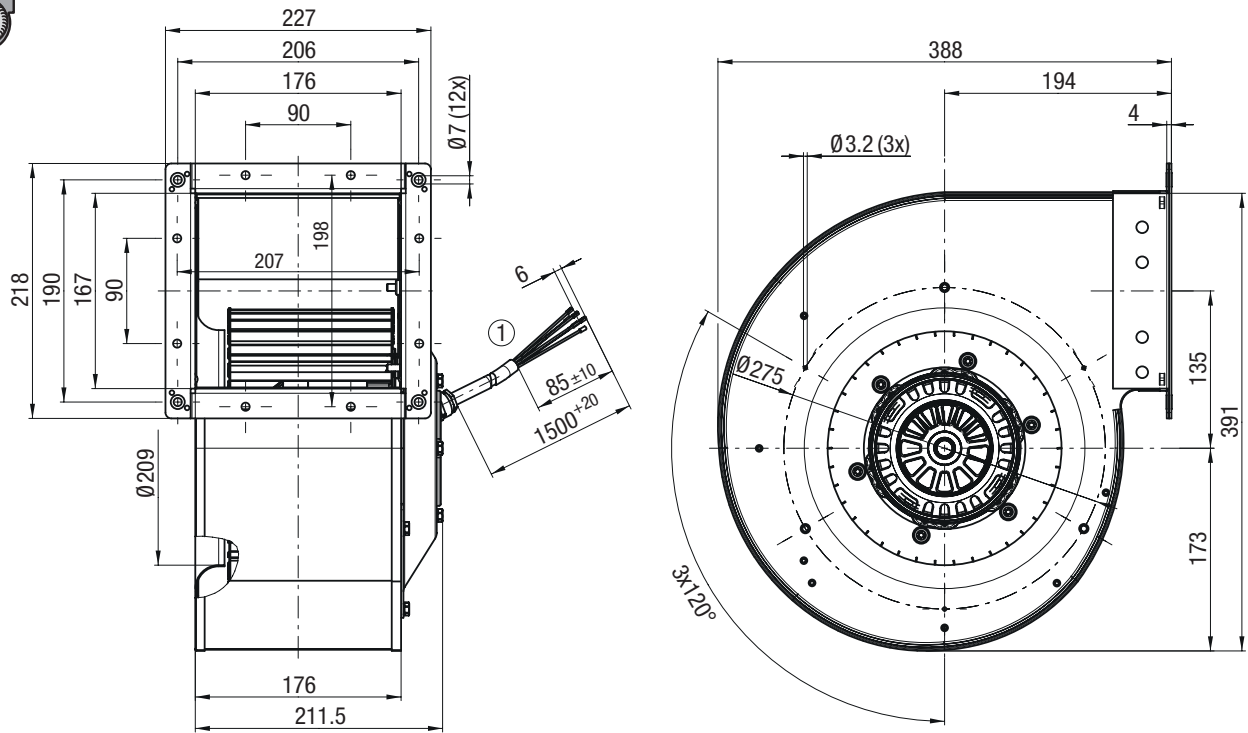

① Cable (halogen-free): BETAtrans<sup>®</sup> 3 GKW flex, 9G 0.75 mm<sup>2</sup>, 9x crimped splices

Pin assignment: see connection diagram



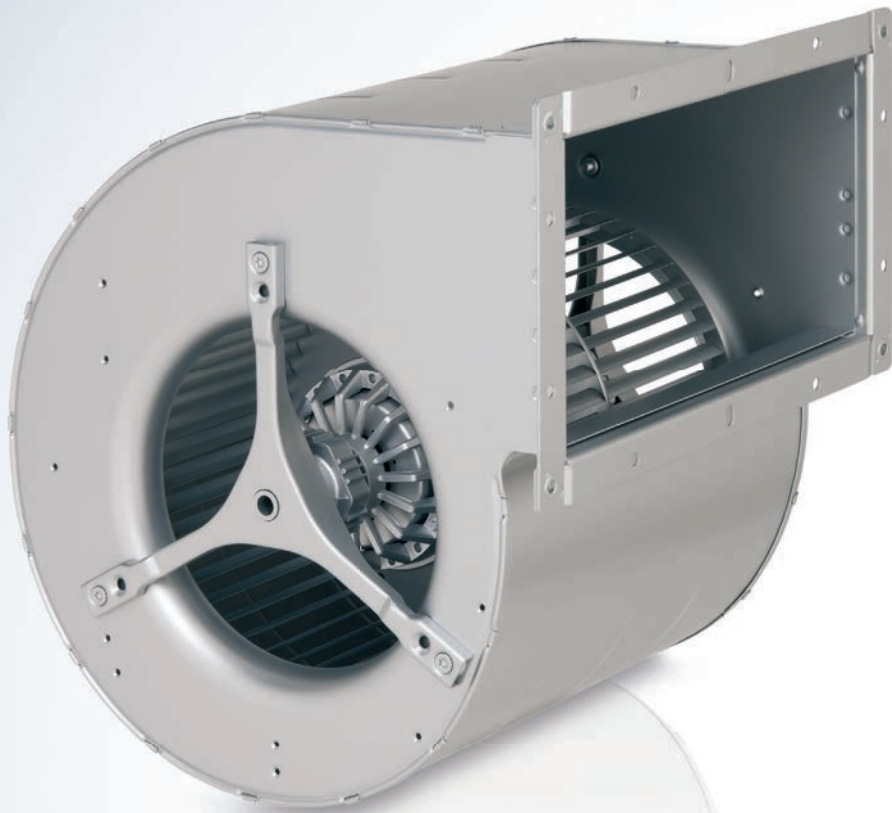



# AC centrifugal fans *vorward curved with housing* Ø 133 - Ø 200, dual-intake

**ebmpapst**

the engineer's choice

	Page
Ø 133 (2-pole)	158
Ø 146 (2-pole)	162
Ø 160 (2-pole)	166
Ø 180 (4-pole)	170
Ø 200 (4-pole)	174

# AC centrifugal fans

forward curved with housing, Ø 133 mm



### Material/surface

- Impeller: Sheet steel galvanized
- Housing: Sheet steel galvanized
- Rotor: Painted black

### Mechanical data

- Direction of rotation: Clockwise viewed toward rotor
- Mode: Continuous operation (S1)
- Mounting: Maintenance-free ball bearings
- Cable exit: lateral

### Standards and approvals

- Conformity with standards: see page 6
- Approvals: EAC

on Page 160	Drawings
on Page 192	Connection diagrams and technical features
on Page 204	Technical parameters & scope
More at	<a href="http://www.ebmpapst.com">www.ebmpapst.com</a>

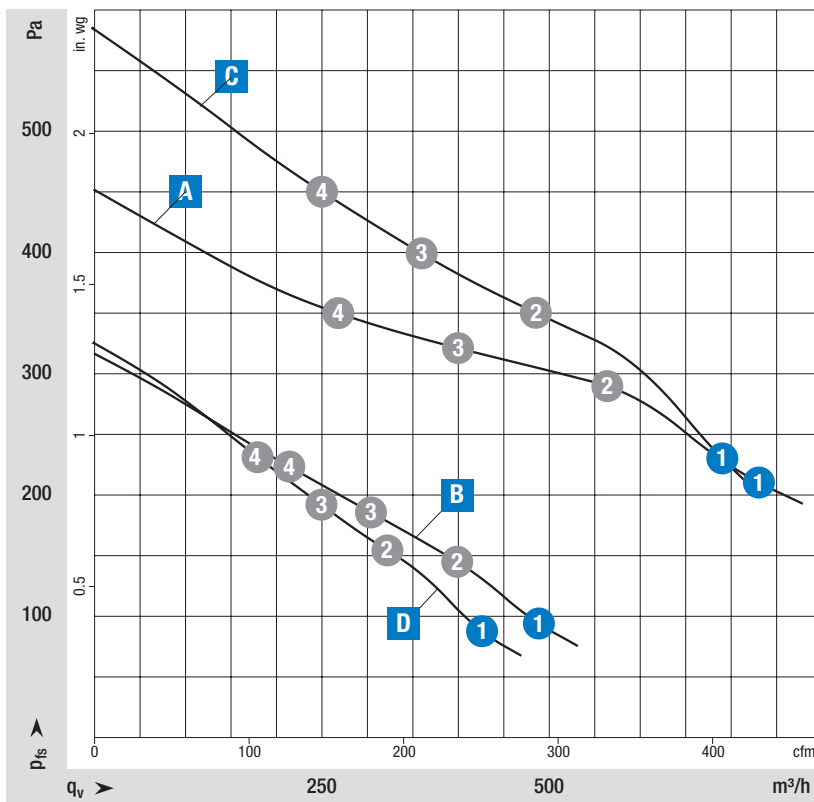

**Measuring requirements**  
 Air performance measured according to: ISO 5801, installation category A, with ebm-papst scroll housing without contact protection.  
 Intake-side sound level:  $L_{pA}$  according to ISO 13347,  $L_{pA}$  measured at 1 m distance from fan axis. The values given are only applicable under the specified measuring conditions and may differ depending on the installation conditions. In the event of deviation from the standard configuration, the parameters must be checked in installed condition.

Curve	Operating point	Nominal voltage	Speed n	Max. Input power $P_{ed}$	Max. Input current I	Sound power level $L_{wA}$	Min. Back pressure	Protection class	Installation position	Perm. ambient temp.	Degree of protection	Insulation class	Conn. diagram
		VDC											
Nominal voltage 400 V AC, 50 Hz													
A	1	400 Δ	2250	195	0,31	70	210	I	Shaft horizontal	-40..+70	IP 44	F	BA9)
	2	400 Δ	2470	154	0,25	69							
	3	400 Δ	2615	122	0,21	69							
	4	400 Δ	2695	101	0,19	70							
B	1	400 Y	1550	105	0,16	60	95	I	Shaft horizontal	-40..+70	IP 44	F	BA9)
	2	400 Y	1765	95	0,15	61							
	3	400 Y	2000	82	0,13	63							
	4	400 Y	2165	73	0,11	65							
Nominal voltage 400 V AC, 60 Hz													
C	1	400 Δ	2350	240	0,37	70	230	I	Shaft horizontal	-40..+50	IP 44	F	BA9)
	2	400 Δ	2725	186	0,29	72							
	3	400 Δ	2905	158	0,25	72							
	4	400 Δ	3025	138	0,22	73							
D	1	400 Y	1450	115	0,18	58	85	I	Shaft horizontal	-40..+50	IP 44	F	BA9)
	2	400 Y	1820	103	0,16	61							
	3	400 Y	2025	95	0,15	63							
	4	400 Y	2185	89	0,14	65							

Values set in blue are nominal data at operating point with maximum load.

Subject to change

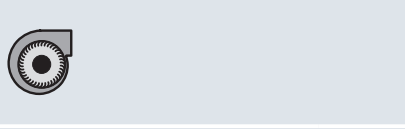
Curve		
	Centrifugal fan with housing	
	Part number	Weight
A	D2D133DB4003	4,00
B		
C		
D		

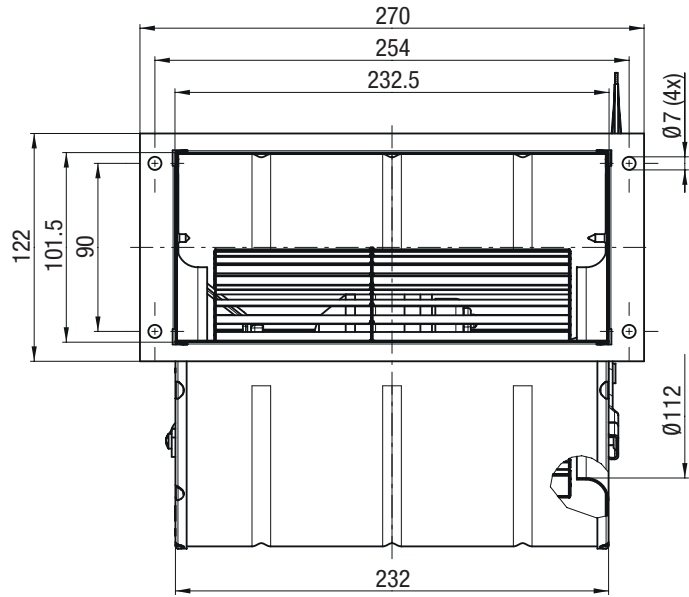
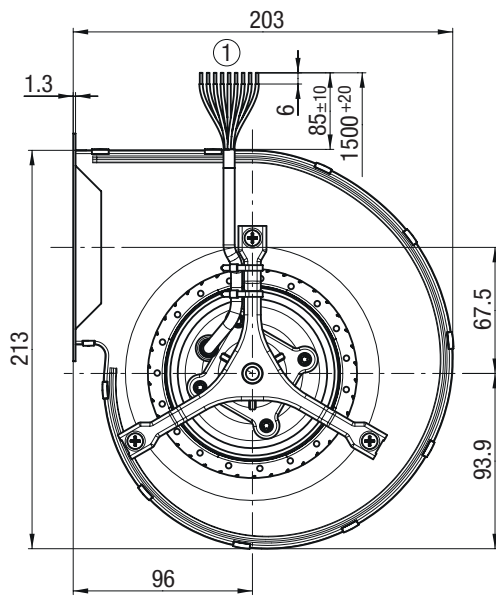

① Cable (halogen-free): BETAtrens<sup>®</sup> GW flex, 9G 0.5 mm<sup>2</sup>, 9x crimped splices

Pin assignment: see connection diagram



# AC centrifugal fans

forward curved with housing, Ø 146 mm



### Material/surface

- Impeller: Sheet steel galvanized
- Housing: Sheet steel galvanized
- Rotor: Painted black

### Mechanical data

- Direction of rotation: Clockwise viewed toward rotor
- Mode: Continuous operation (S1)
- Mounting: Maintenance-free ball bearings
- Cable exit: lateral

### Standards and approvals

- Conformity with standards: see page 6
- Approvals: EAC

on Page 164	Drawings
on Page 192	Connection diagrams and technical features
on Page 204	Technical parameters & scope
More at	<a href="http://www.ebmpapst.com">www.ebmpapst.com</a>

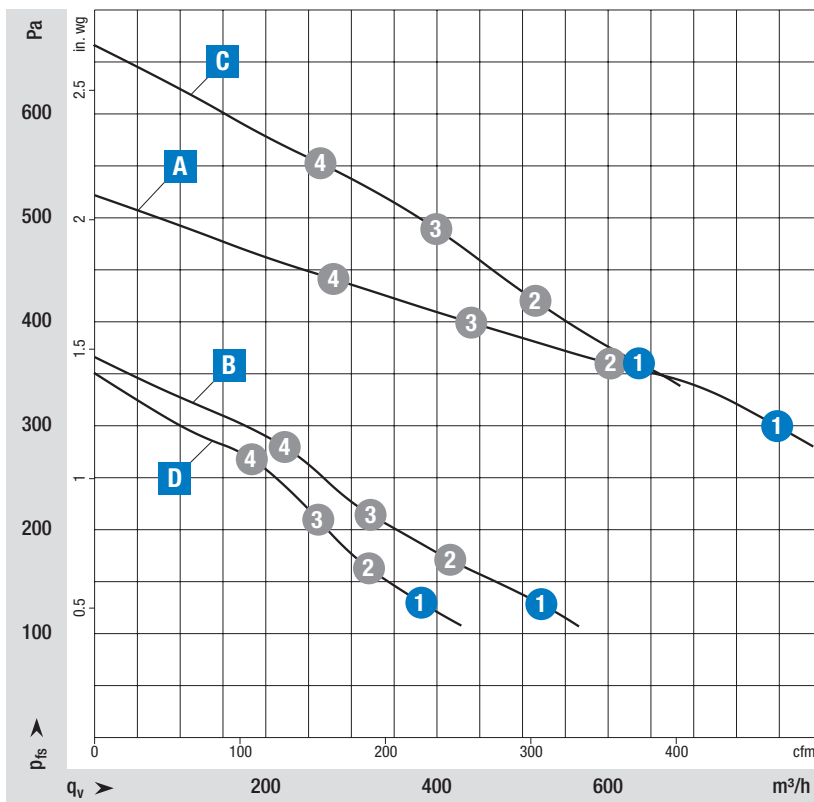

**Measuring requirements**  
 Air performance measured according to: ISO 5801, installation category A, with ebm-papst scroll housing without contact protection.  
 Intake-side sound level: L<sub>A</sub> according to ISO 13347, L<sub>A</sub> measured at 1 m distance from fan axis. The values given are only applicable under the specified measuring conditions and may differ depending on the installation conditions. In the event of deviation from the standard configuration, the parameters must be checked in installed condition.

Curve	Operating point	Nominal voltage	Speed n	Max. Input power $P_{ed}$	Max. Input current I	Sound power level L <sub>WA</sub>	Min. Back pressure	Protection class	Installation position	Perm. ambient temp.	Degree of protection	Insulation class	Conn. diagram
		VDC											
Nominal voltage 400 V AC, 50 Hz													
A	1	400 Δ	2300	265	0,41	72	300	I	Shaft horizontal	-40..+60	IP 44	F	BA9)
	2	400 Δ	2495	212	0,34	72							
	3	400 Δ	2610	178	0,29	73							
	4	400 Δ	2720	138	0,24	75							
B	1	400 Y	1500	150	0,23	61	130	I	Shaft horizontal	-40..+60	IP 44	F	BA9)
	2	400 Y	1735	136	0,21	63							
	3	400 Y	1920	124	0,19	66							
	4	400 Y	2180	104	0,16	70							
Nominal voltage 400 V AC, 60 Hz													
C	1	400 Δ	2500	305	0,47	73	360	I	Shaft horizontal	-40..+45	IP 44	F	BA9)
	2	400 Δ	2690	270	0,42	74							
	3	400 Δ	2875	235	0,36	76							
	4	400 Δ	3040	196	0,31	78							
D	1	400 Y	1500	150	0,24	60	125	I	Shaft horizontal	-40..+45	IP 44	F	BA9)
	2	400 Y	1690	146	0,22	63							
	3	400 Y	1890	138	0,21	66							
	4	400 Y	2110	129	0,20	69							

Values set in blue are nominal data at operating point with maximum load.

Subject to change

Curve	Centrifugal fan with housing	
	Part number	Weight kg
A	D2D146AA1203	4,40
B		
C		
D		



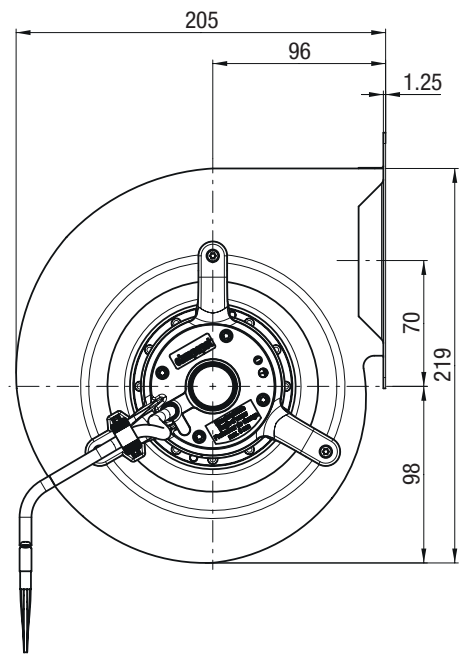
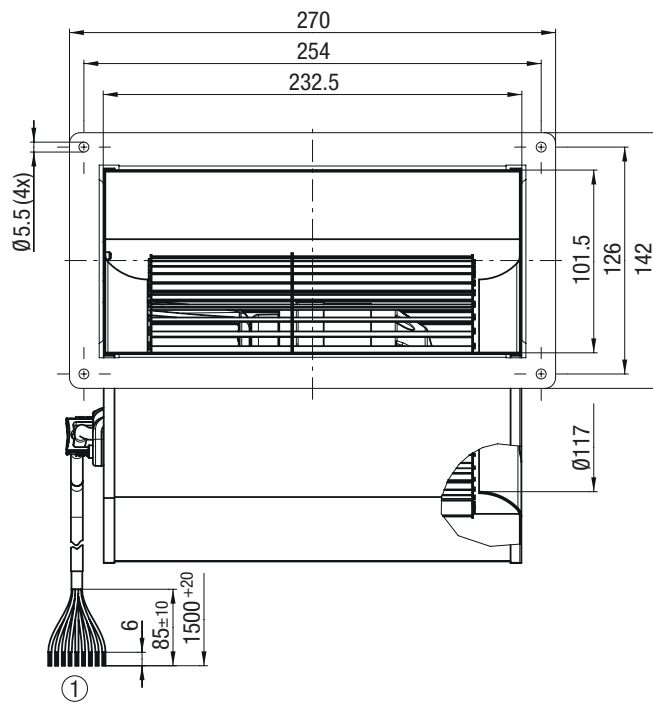

① Cable (halogen-free): BETrans<sup>®</sup> GW flex R, 9G 0.5 mm<sup>2</sup>, 9x crimped splices

Pin assignment: see connection diagram





# AC centrifugal fans

forward curved with housing, Ø 160 mm



### Material/surface

- Impeller: Sheet steel galvanized
- Housing: Sheet steel galvanized
- Rotor: Painted black

### Mechanical data

- Direction of rotation: Clockwise viewed toward rotor
- Mode: Continuous operation (S1)
- Mounting: Maintenance-free ball bearings
- Cable exit: lateral

### Standards and approvals

- Conformity with standards: see page 6
- Approvals: EAC

on Page 168	Drawings
on Page 192	Connection diagrams and technical features
on Page 204	Technical parameters & scope
More at	<a href="http://www.ebmpapst.com">www.ebmpapst.com</a>

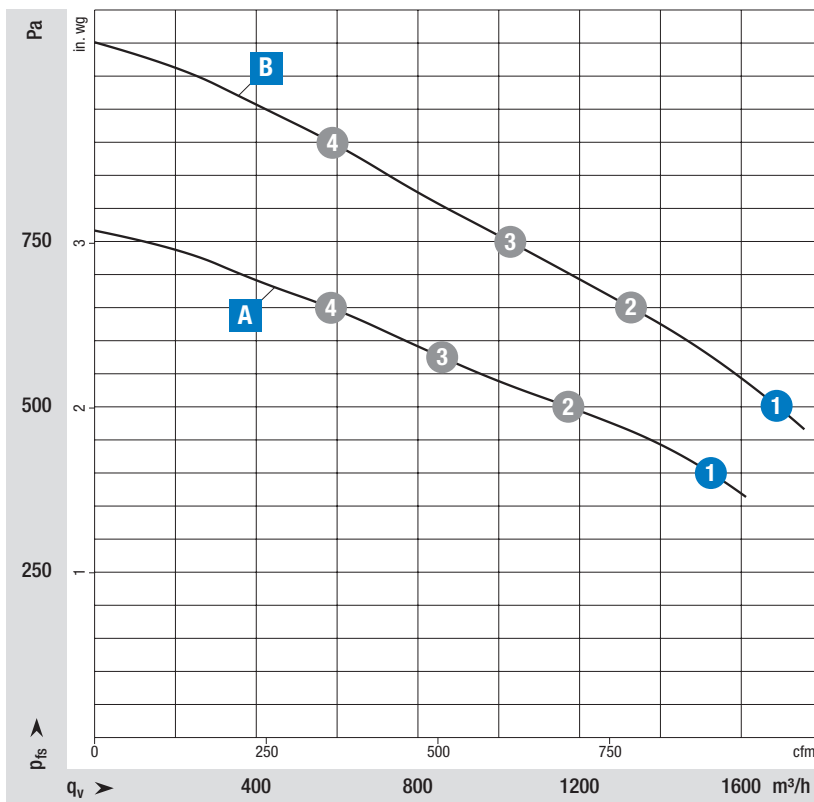

#### Measuring requirements

Air performance measured according to: ISO 5801, installation category A, with ebm-papst scroll housing without contact protection. Intake-side sound level:  $L_{pA}$  according to ISO 13347,  $L_{pA}$  measured at 1 m distance from fan axis. The values given are only applicable under the specified measuring conditions and may differ depending on the installation conditions. In the event of deviation from the standard configuration, the parameters must be checked in installed condition.

Curve	Operating point	Nominal voltage	Speed n	Max. Input power $P_{ed}$	Max. Input current I	Sound power level $L_{wA}$	Min. Back pressure	Protection class	Installation position	Perm. ambient temp.	Degree of protection	Insulation class	Conn. diagram
		VDC	rpm	W	A	dB(A)							
Nominal voltage 400 V AC, 50 Hz													
A	1	400Y	2700	700	1,28	80	400	I	Shaft horizontal	-40..+75	IP 00	F	BA9)
	2	400Y	2795	523	1,04	80							
	3	400Y	2835	428	0,93	81							
	4	400Y	2870	355	0,85	82							
Nominal voltage 400 V AC, 60 Hz													
B	1	400Y	3000	1055	1,70	83	500	I	Shaft horizontal	-40..+65	IP 00	F	BA9)
	2	400Y	3160	807	1,33	83							
	3	400Y	3240	689	1,15	84							
	4	400Y	3315	560	0,97	86							

Values set in blue are nominal data at operating point with maximum load.

Subject to change

Curve	Centrifugal fan with housing	
	Part number	Weight kg
A	D2D160BE0203	9,80
B		

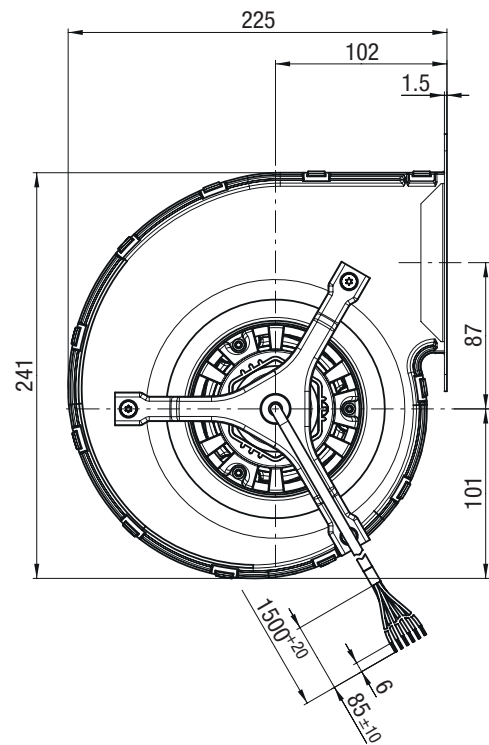
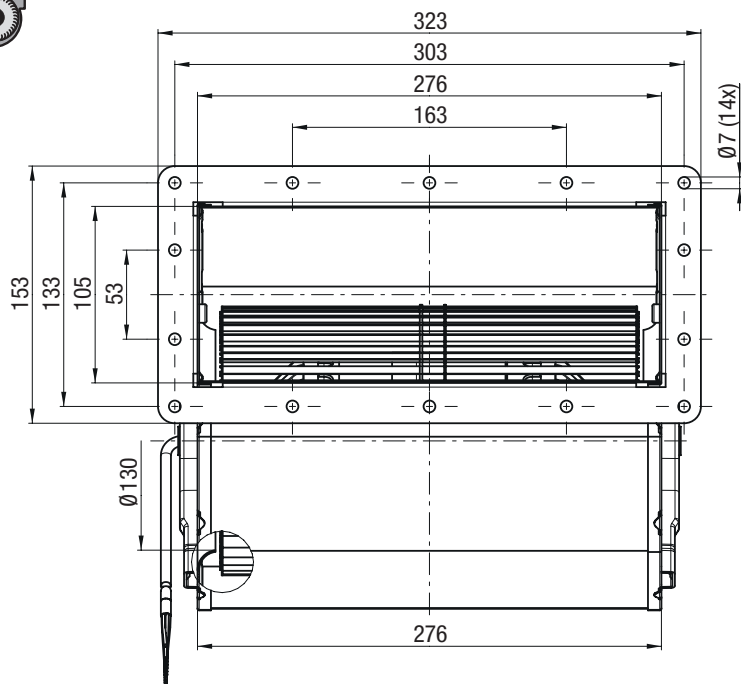

① Cable (halogen-free): BETAtans<sup>®</sup> GKW flex R, 9G 0.5 mm<sup>2</sup>, 6x crimped splices

Pin assignment: see connection diagram



# AC centrifugal fans

forward curved with housing, Ø 180 mm



### Material/surface

- Impeller: Sheet steel galvanized
- Housing: Sheet steel galvanized
- Rotor: Painted black

### Mechanical data

- Direction of rotation: Clockwise viewed toward rotor
- Mode: Continuous operation (S1)
- Mounting: Maintenance-free ball bearings
- Cable exit: lateral

### Standards and approvals

- Conformity with standards: see page 6
- Approvals: EAC

on Page 172	Drawings
on Page 192	Connection diagrams and technical features
on Page 204	Technical parameters & scope
More at	<a href="http://www.ebmpapst.com">www.ebmpapst.com</a>

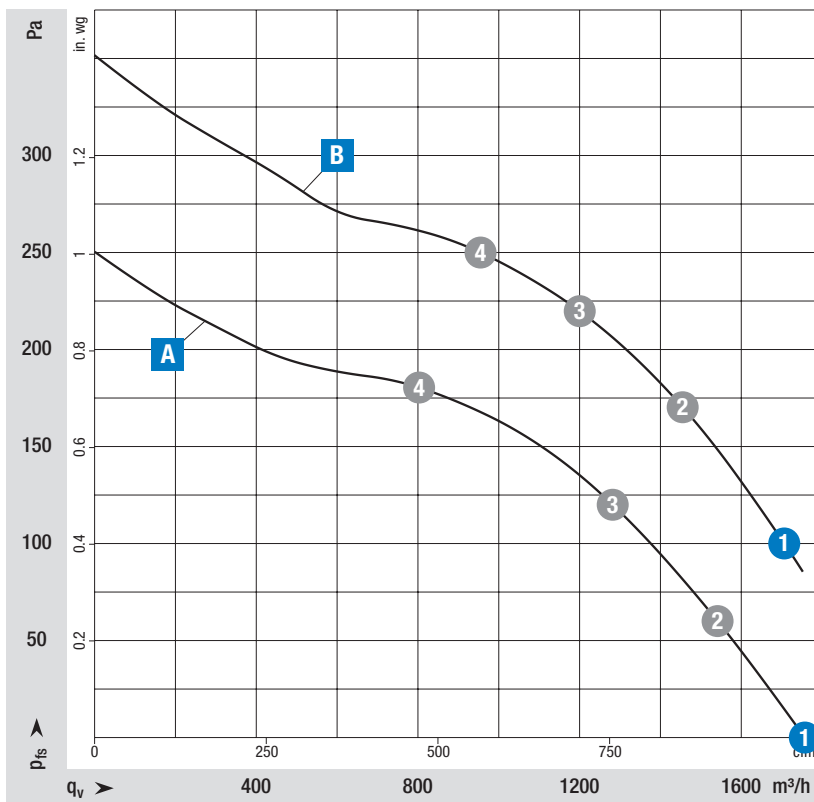

#### Measuring requirements

Air performance measured according to: ISO 5801, installation category A, with ebm-papst scroll housing without contact protection. Intake-side sound level:  $L_{wA}$  according to ISO 13347,  $L_{wA}$  measured at 1 m distance from fan axis. The values given are only applicable under the specified measuring conditions and may differ depending on the installation conditions. In the event of deviation from the standard configuration, the parameters must be checked in installed condition.

Curve	Operating point	Nominal voltage	Speed n	Max. Input power $P_{ed}$	Max. Input current I	Sound power level L <sub>WA</sub>	Min. Back pressure	Protection class	Installation position	Perm. ambient temp.	Degree of protection	Insulation class	Conn. diagram
		VDC											
Nominal voltage 400 V AC, 50 Hz													
A	1	400Y	1100	255	0,50	73	0	I	Shaft horizontal	-40..+70	IP 54	F	BA9)
	2	400Y	1175	216	0,42	70							
	3	400Y	1245	181	0,38	68							
	4	400Y	1345	125	0,33	64							
Nominal voltage 480 V AC, 60 Hz													
B	1	480Y	1370	320	0,50	73	100	I	Shaft horizontal	-40..+70	IP 54	F	BA9)
	2	480Y	1450	274	0,44	71							
	3	480Y	1515	232	0,40	70							
	4	480Y	1575	194	0,37	69							

Values set in blue are nominal data at operating point with maximum load.

Subject to change

Curve	Centrifugal fan with housing	
	Part number	Weight
A	D4D180BB0903	9,10
B		

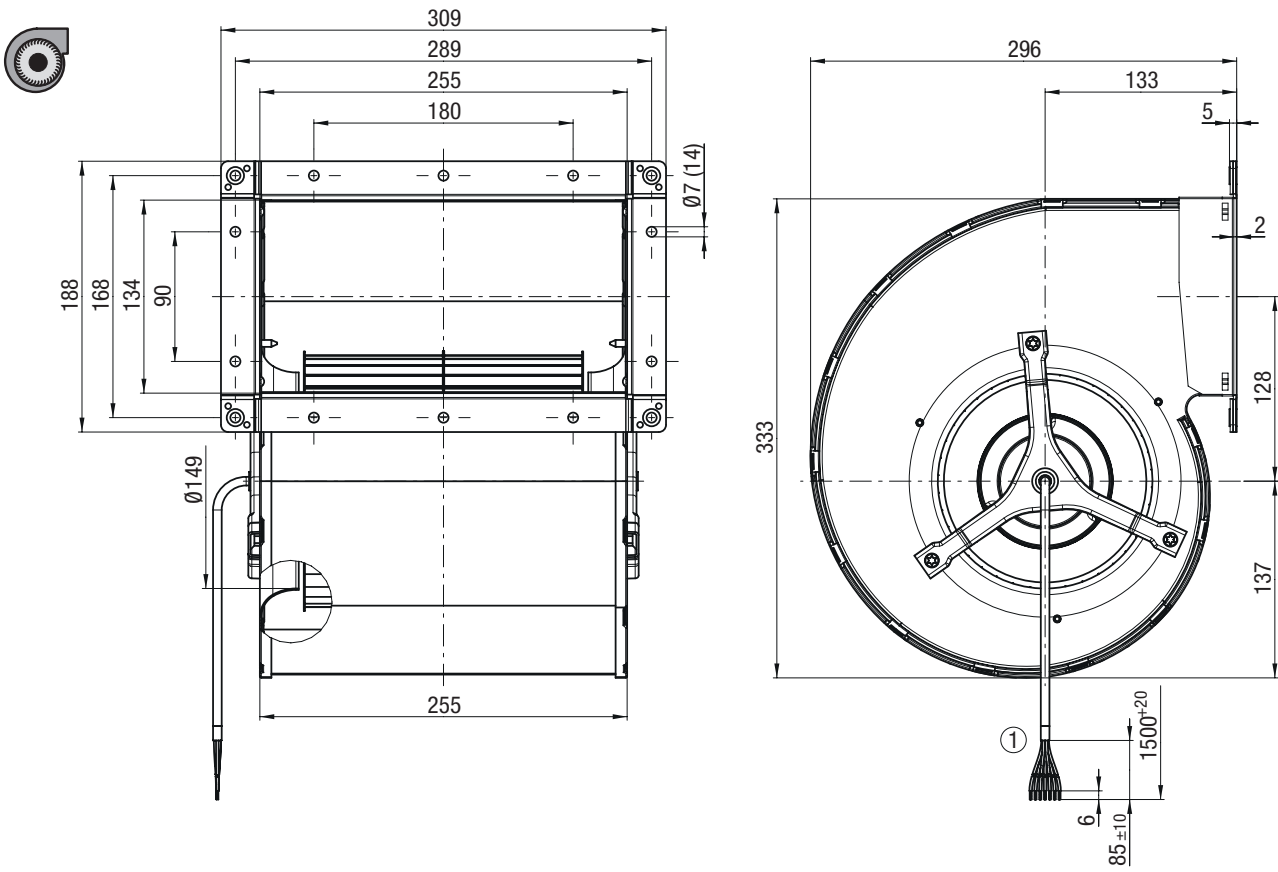

① Cable (halogen-free): BETAtrans<sup>®</sup> 3 GKW flex, sw 6G 0.5 mm<sup>2</sup>, 6x crimped splices

Pin assignment: see connection diagram





# AC centrifugal fans

forward curved with housing, Ø 200 mm



### Material/surface

- Impeller: Sheet steel galvanized
- Housing: Sheet steel galvanized
- Rotor: Painted black

### Mechanical data

- Direction of rotation: Clockwise viewed toward rotor
- Mode: Continuous operation (S1)
- Mounting: Maintenance-free ball bearings
- Cable exit: lateral

### Standards and approvals

- Conformity with standards: see page 6
- Approvals: EAC

on Page 176	Drawings
on Page 192	Connection diagrams and technical features
on Page 204	Technical parameters & scope
More at	<a href="http://www.ebmpapst.com">www.ebmpapst.com</a>

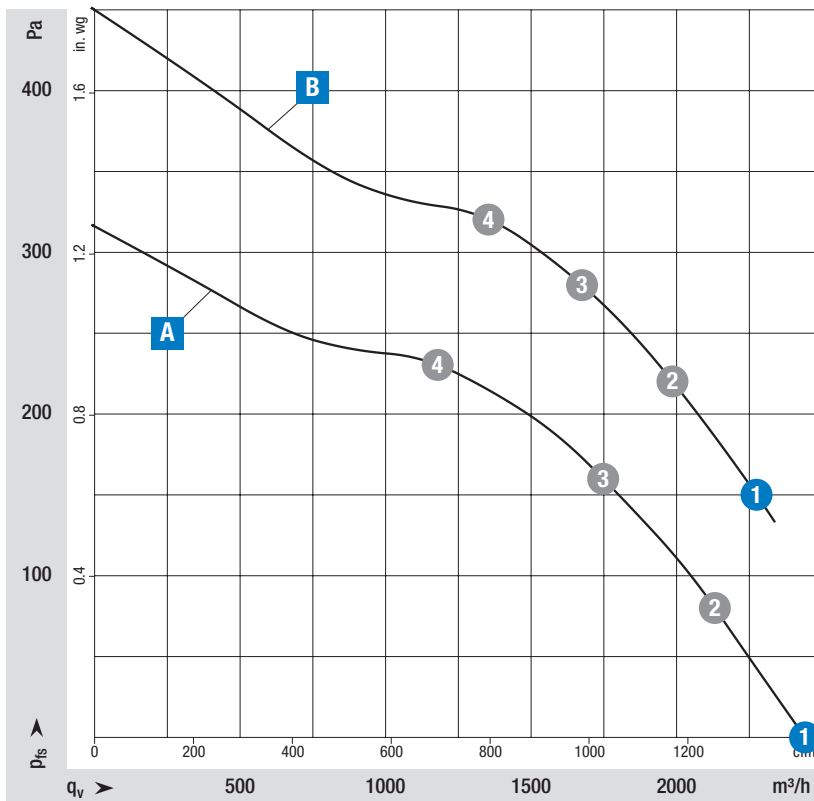

**Measuring requirements**  
 Air performance measured according to: ISO 5801, installation category A, with ebm-papst scroll housing without contact protection.  
 Intake-side sound level: L<sub>wA</sub> according to ISO 13347, L<sub>wA</sub> measured at 1 m distance from fan axis. The values given are only applicable under the specified measuring conditions and may differ depending on the installation conditions. In the event of deviation from the standard configuration, the parameters must be checked in installed condition.

Curve	Operating point	Nominal voltage		Max. Input power $P_{ed}$	Max. Input current I	Sound power level $L_{wA}$	Min. Back pressure	Protection class	Installation position	Perm. ambient temp.	Degree of protection	Insulation class	Conn. diagram
		VDC	rpm										
Nominal voltage 400 V AC, 50 Hz													
A	1	400Y	1100	405	0,75	76	0	I	Shaft horizontal	-40..+65	IP 54	F	BA9)
	2	400Y	1185	345	0,66	73							
	3	400Y	1250	286	0,59	70							
	4	400Y	1330	211	0,52	67							
Nominal voltage 480 V AC, 60 Hz													
B	1	480Y	1370	500	0,80	75	150	I	Shaft horizontal	-40..+60	IP 54	F	BA9)
	2	480Y	1445	445	0,70	74							
	3	480Y	1505	384	0,64	73							
	4	480Y	1565	323	0,58	71							

Values set in blue are nominal data at operating point with maximum load.

Subject to change

Curve	Centrifugal fan with housing	
	Part number	Weight kg
A	D4D200BA0103	10,80
B		

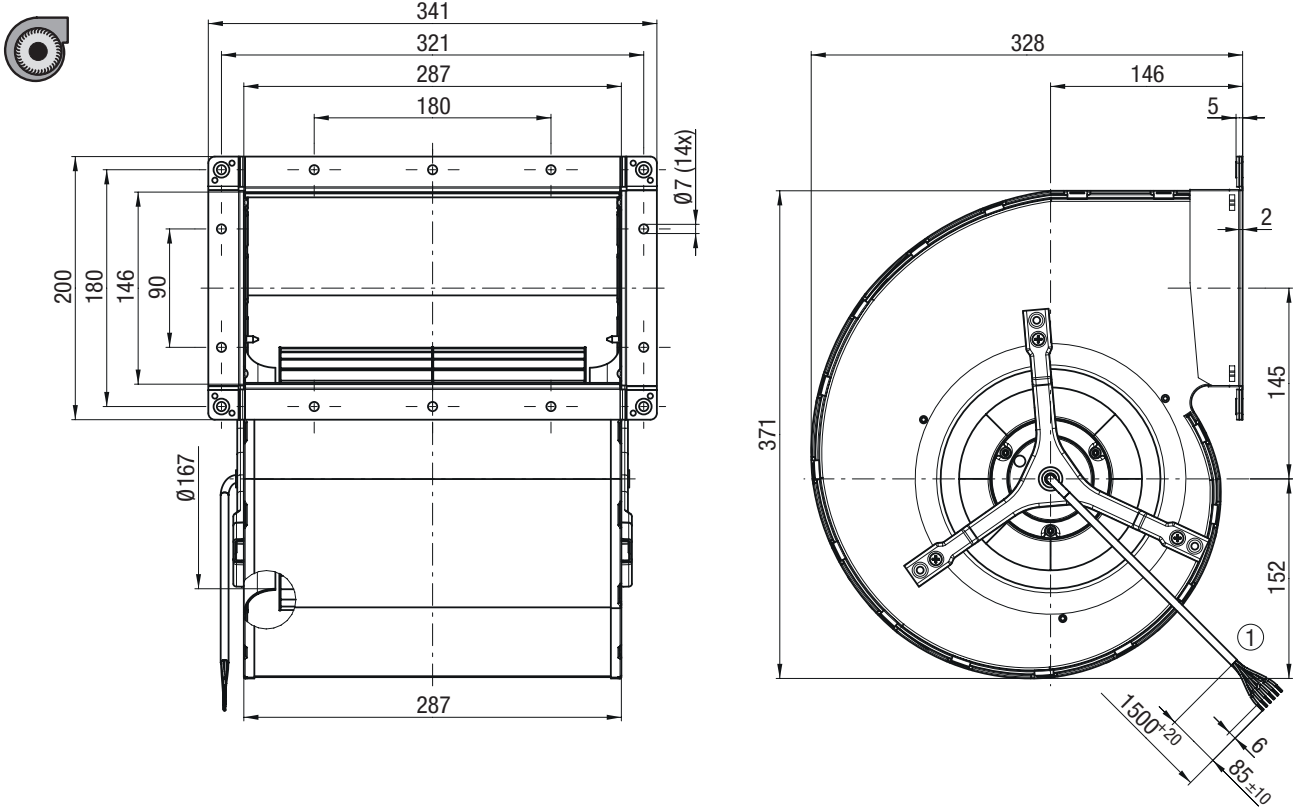

① Cable (halogen-free): BETAtans<sup>®</sup> 3 GKW flex, sw 6G 0.5 mm<sup>2</sup>, 6x crimped splices

Pin assignment: see connection diagram



### it's time for tomorrow

We extend the limits of what's feasible every day. Our longstanding engineering expertise gives us the capability to lead the way in technological development. We have a range of products with an enormous potential for efficient allround solutions to meet each individual facet of your needs. We're your partner at every phase of the process chain, coming up with new ideas while keeping the big picture in mind. We have a wide range of product-specific knowledge in building the right drive designs for you. We're always in tune with the times to offer you excellent ideas, outstanding innovations and hands-on-service.

### EQ<sup>3</sup> – Inclusive of Economic Quality

EQ<sup>3</sup> is the ebm-papst concept for the future, which combines intelligent drive solutions with important performance characteristics. All gear motors impress with unsurpassed values in terms of lifetime and performance, and move the future through environmental protection with the highest level of efficiency. Creating the future together – it's time for tomorrow!

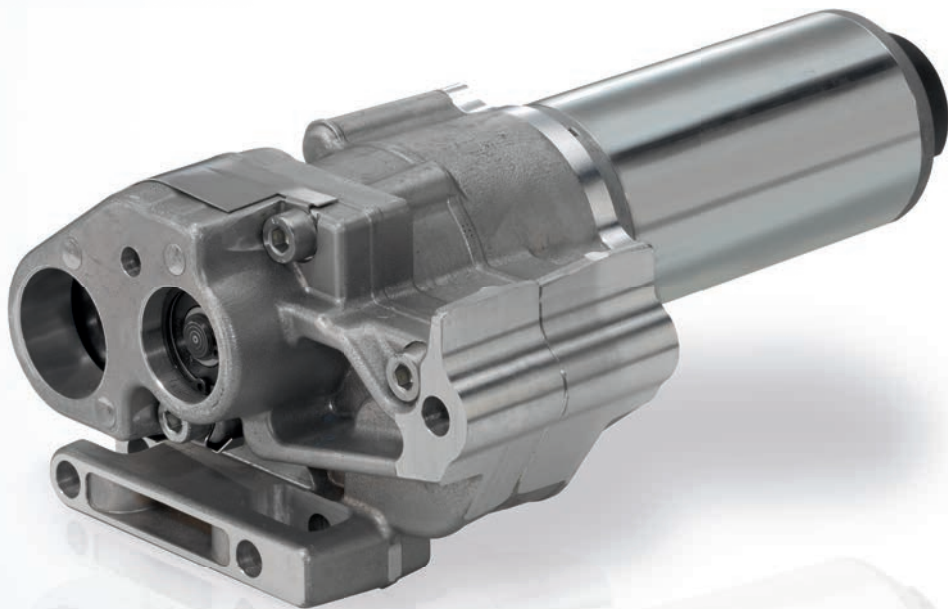

# Drive concepts ebm-papst

*Powerful, Safe, Reliable*

**ebmpapst**

the engineer's choice

	Page
Solutions for the most demanding requirements	180

# Solutions for the most demanding requirements

*Drive concepts with future*

## The highest level of safety for passenger transportation

Personal safety plays an especially important role in the transportation of passengers in public transit. In this context, the focus is on components for moving entry aids and door systems, which have their own special requirements with regard to performance.

Demographic change also puts high demands on systems that automatically open and close doors, and with respect the management of barriers.

## The right drive concept at every step

With its technologically exemplary drive concepts, ebm-papst implements innovative and reliable gear motors for many conceivable motion requirements in the area of passenger transportation.

Mature technologies, maximum efficiency and reliability along with extreme resilience and lifetime are supplemented by technical refinements and a broad service range.

Comprehensive development services and decades of experience stand for extraordinary solutions that also allow for the combination of planetary, spur and angle gearheads.

## Trailblazing drive solutions

Motion components are subject to great loads, especially when it comes to train operations, and result in important aspects in terms of implementation:

- Target-oriented implementation of demanding market requirements in view of performance density and durability
- Compliance with specifications and technical requirement by legislation and standards
- High corrosion-resistance and functional safety even in extreme weather conditions
- Vibration resistance to compensate for vibration responses

ebm-papst considers these requirements the main criteria for the design of these intelligent and powerful gear motors. They are virtually unbeatable when it comes to durability, quality and safety, and hence represent a safe and profitable investment.

## Services for sophisticated needs

Our well-rounded range of effective services adds to your advantages. We assume responsibility for the finished, delivered product providing you with reliability, attentiveness and excellent performance throughout the entire product design and manufacturing cycles. Our employees, who daily live up their commitment to service, are your guarantee for success.

The bottom line is service unparalleled in the market.

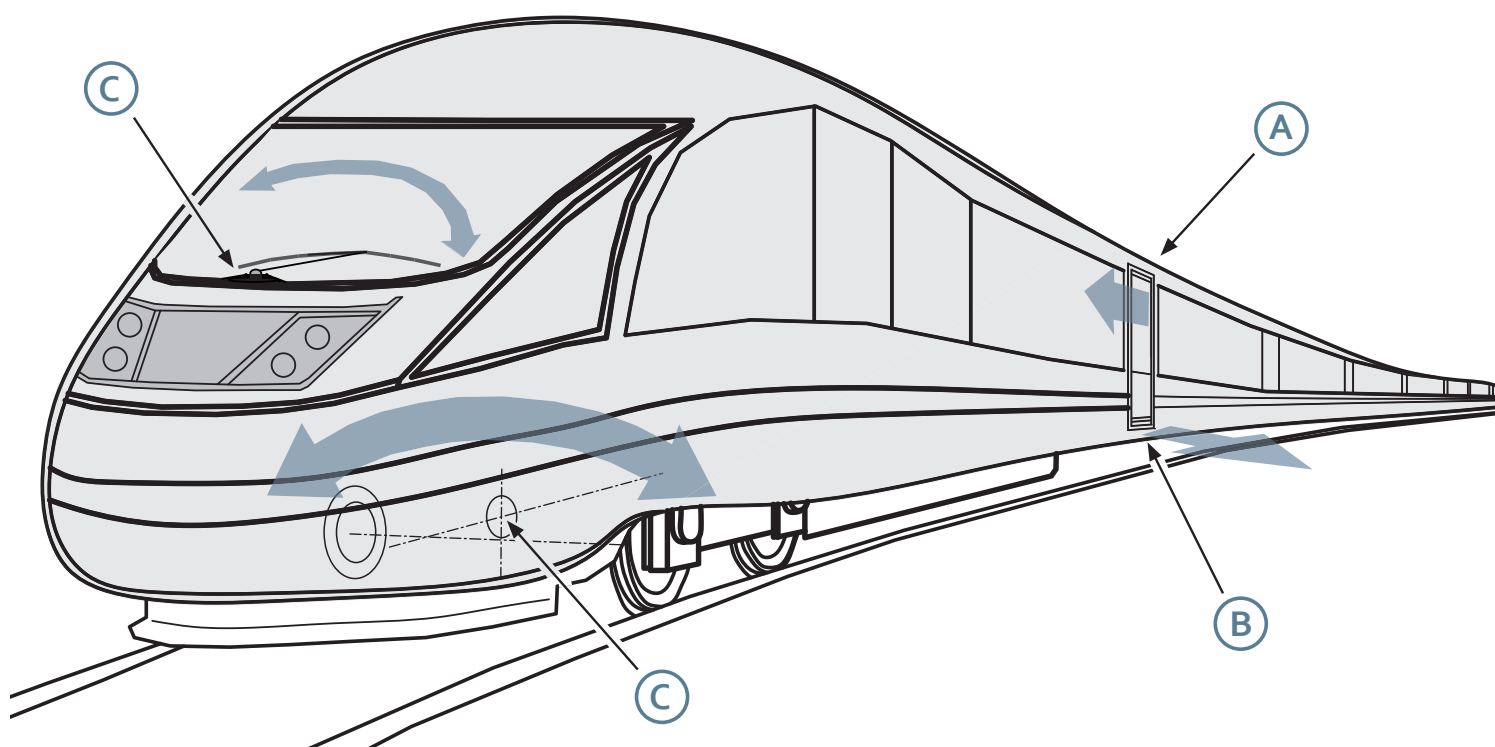



**A** Door drives:



One-stage planetary gearhead for train doors.



Planetary gearhead motor Performax 63 for sliding and locking.

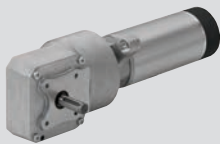

Angle/planetary gearhead combination for the safe sliding and locking of train doors.



Special drive for sliding plug door drives with two outputs.

**B** Drives for entry aids:



Three-stage spur gearheads for the sliding and holding of sliding steps.



Special angle gearhead with combined planetary/crown technology for folding steps and ramps.

**C** Special applications:



Two-stage EtaCrown gearhead with special reinforcements for windscreen wipers.



One-stage EtaCrown angle gearhead for tilt technology.



# Accessories *for rail technology*

**ebmpapst**

the engineer's choice

	Page
FlowGrid air inlet grill	184
Mounting dimensions for centrifugal modules	185
Inlet rings for centrifugal fans	186

# FlowGrid air inlet grill

efficient noise reduction



## FlowGrid air inlet grill

Part number	fan size	Ø B (mm)	Ø C (mm)	Ø E (mm)	S (mm)	H (mm)	N* (mm)	Weight (g)
20282-2-2957	250 280	280	245 -261	4,5	3,5	40	2 ± 0,5 Nm	144
25312-2-2957	310	315	288 -292	5,5	3,5	49	2 ± 0,5 Nm	232

Subject to change

\* Recommended tightening torque for fastening screws

The air performance of ebm-papst fans is not the only thing measured on the state-of-the-art, in-house test stand.

The acoustic behavior of the fans is also examined and the measuring results are included in the technical documentation. Please note that the measurements are taken under ideal conditions with undisturbed inflow and outflow. If the fans are later installed in applications where limited space is available, the noise information listed in the documentation will probably not be applicable.

In order to minimize the negative impact of the installation situation, ebm-papst offers the FlowGrid airinlet guard shown here.

It is mounted on the fan's intake side and effectively reduces the noise in the fan's overall frequency range; especially the disturbing tonal noise in the low frequency range.

The result is a far lower sound pressure level and pleasant running noise.

Since the level of noise reduction is dependent on the installation circumstances, it is not possible to provide generally applicable information here.

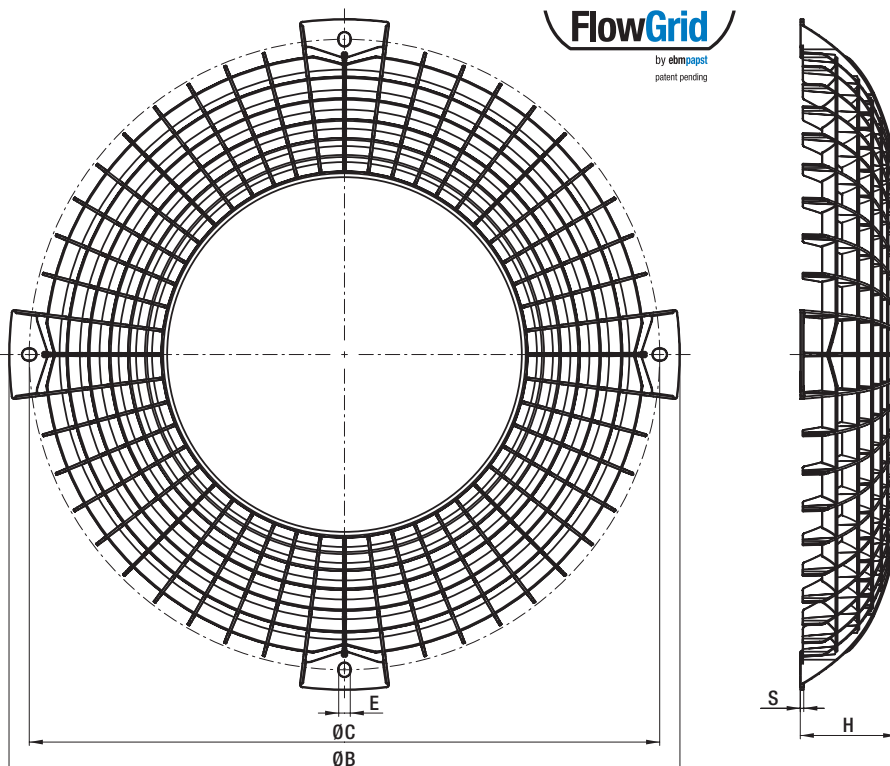

Would you like to find out more?

If you need an installation guide or more information about the dimensions, go to:

[www.ebmpapst.com/flowgrid-manual](http://www.ebmpapst.com/flowgrid-manual)

or scan the QR code below:



# Mounting dimensions

for EC centrifugal modules  $\varnothing 250$ ,  $\varnothing 280$ ,  $\varnothing 310$

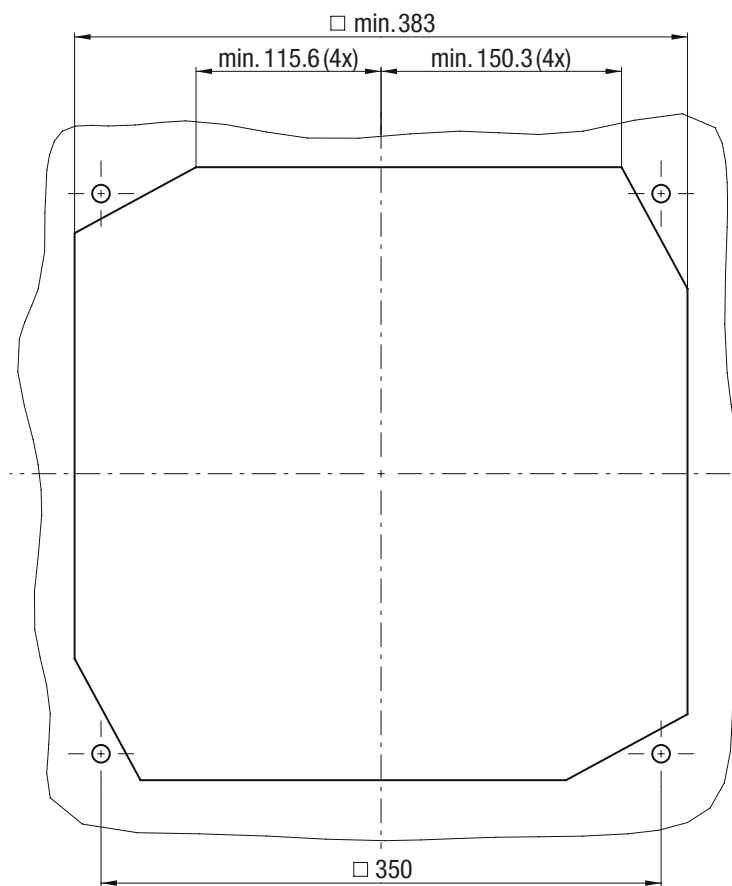

# Inlet rings

for centrifugal fans



Fan size 190, RadiCal

Part number

09576-2-4013

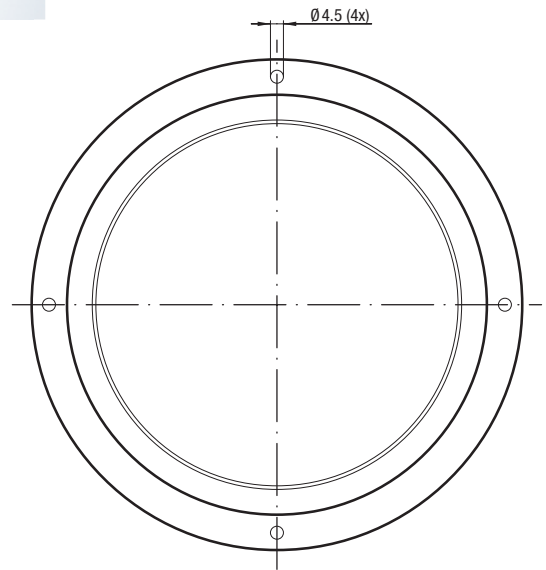
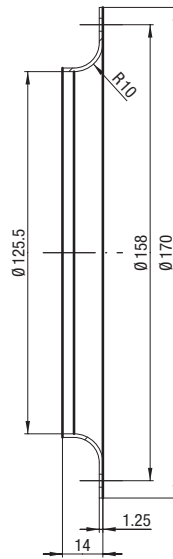

Fan size 220, RadiCal

Part number

09609-2-4013

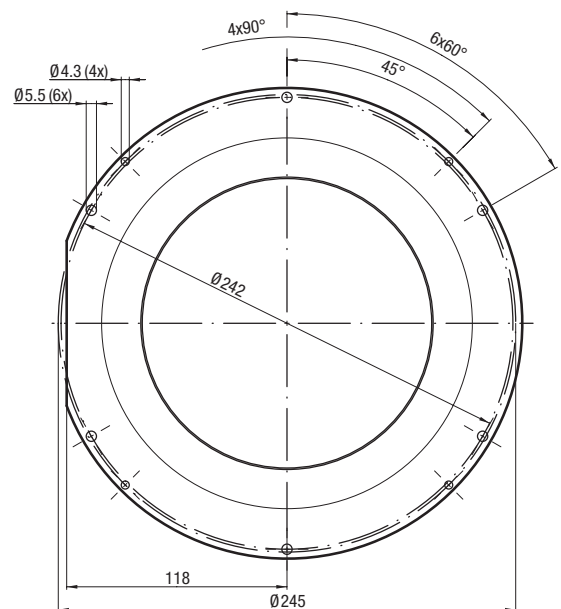
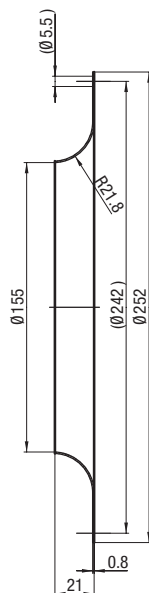

Fan size 250, RadiCal
Part number
96359-2-4013

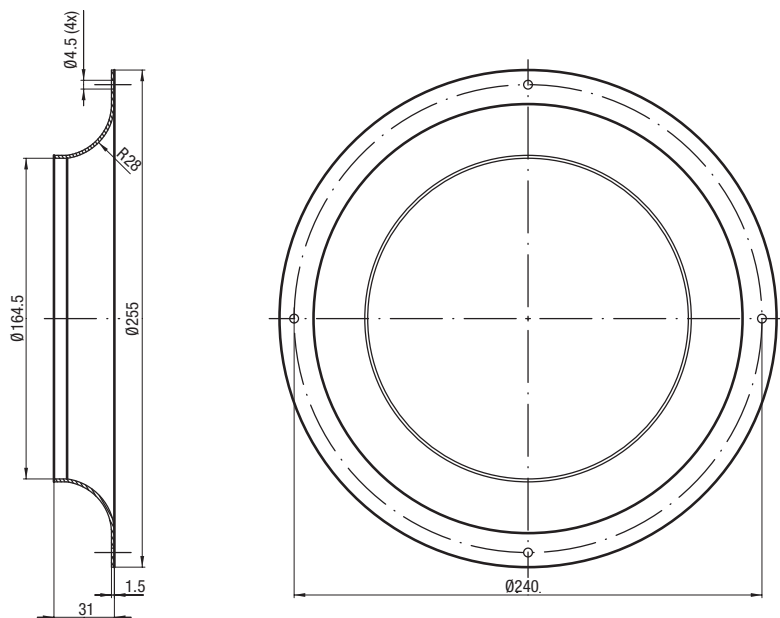

Fan size 250, Aluminium impeller
Part number
25070-2-4013

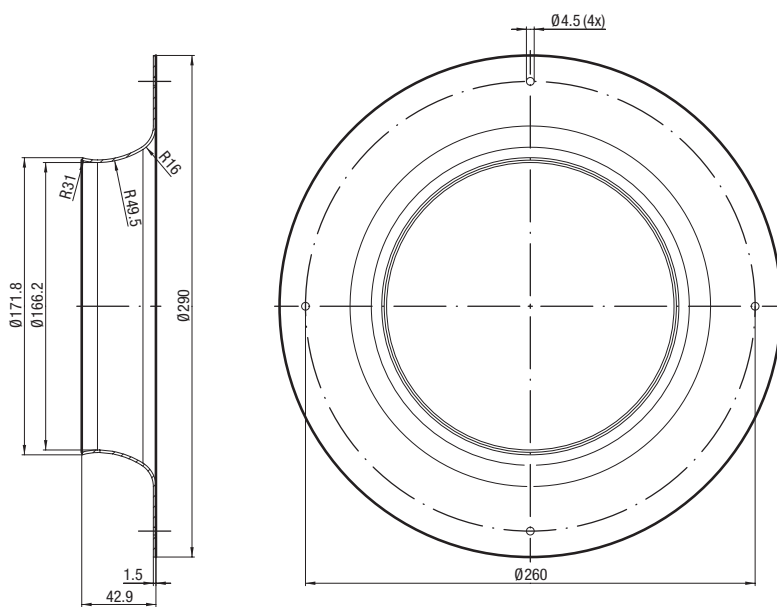

Fan size 280, RadiCal
Part number
28000-2-4013

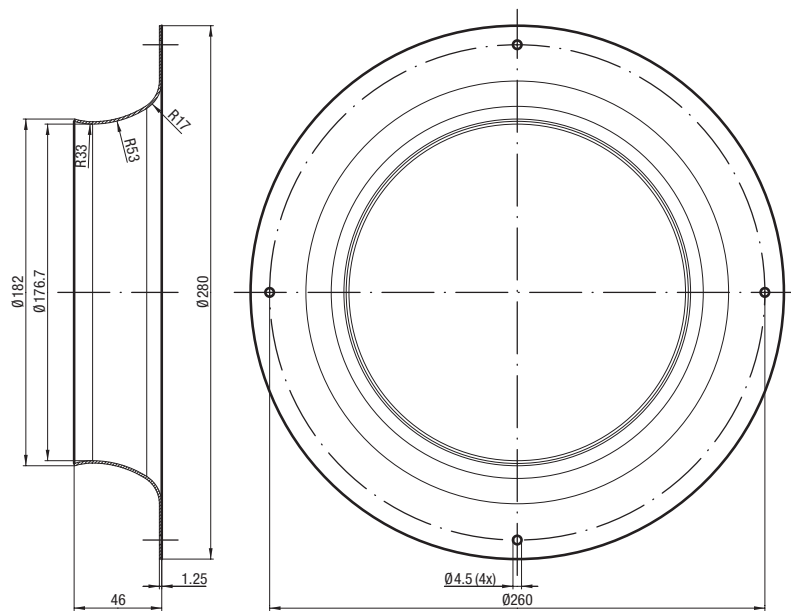

# Inlet rings

for centrifugal fans

Fan size 280, Aluminium impeller

Part number

28070-2-4013

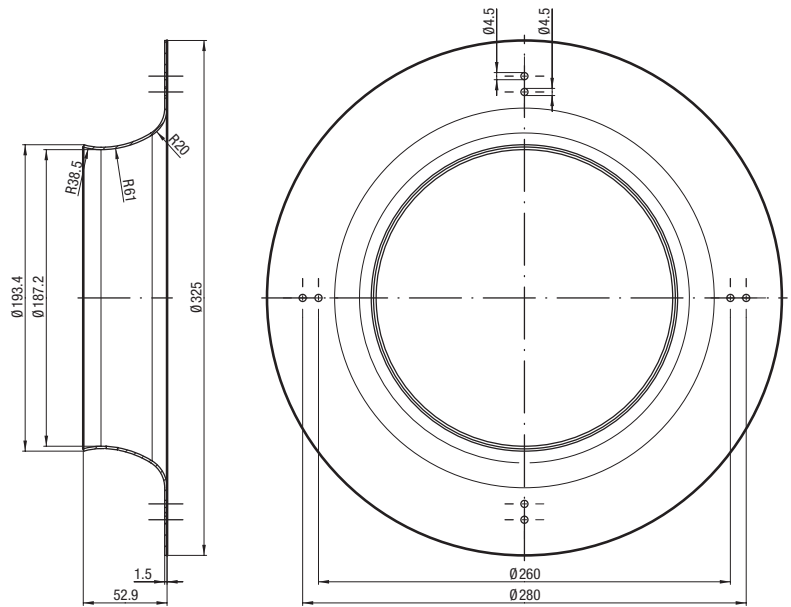

Fan size 310, RadiCal

Part number

31000-2-4013

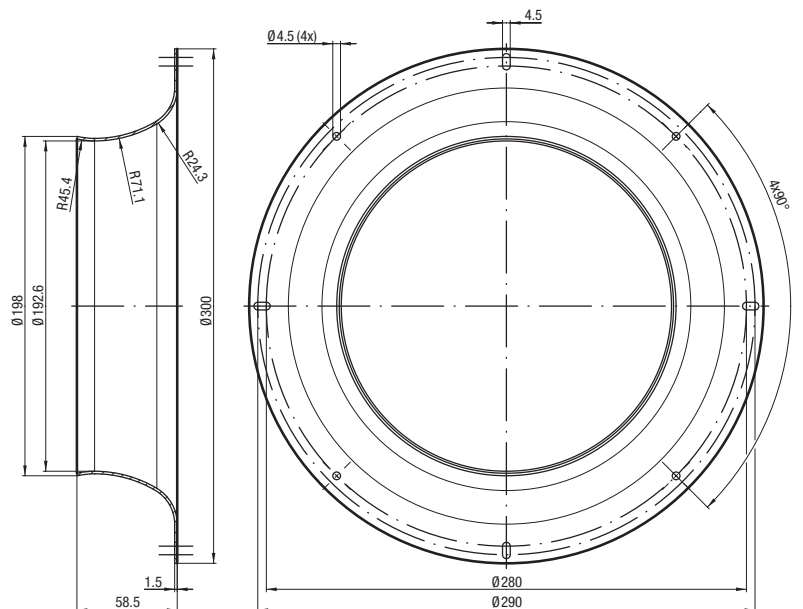



Fan size 310, Aluminium impeller
Part number
31570-2-4013

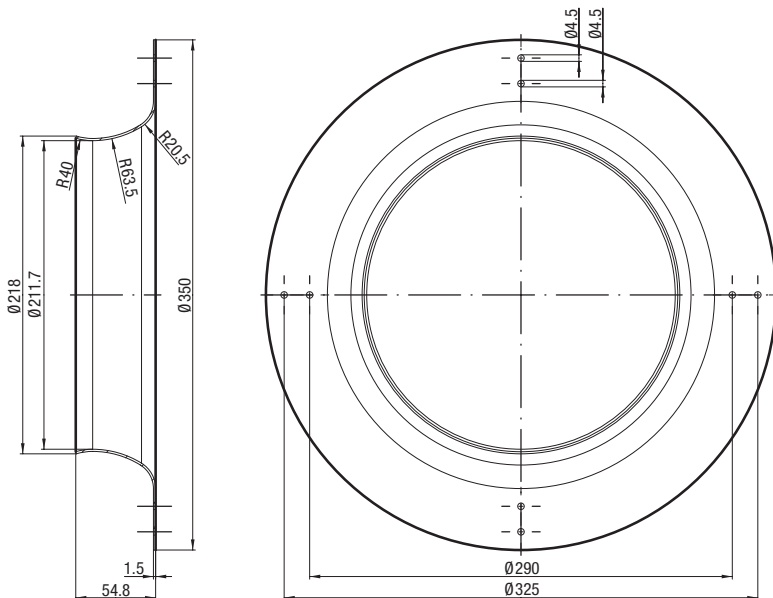

Fan size 355, RadiCal
Part number
35500-2-4013

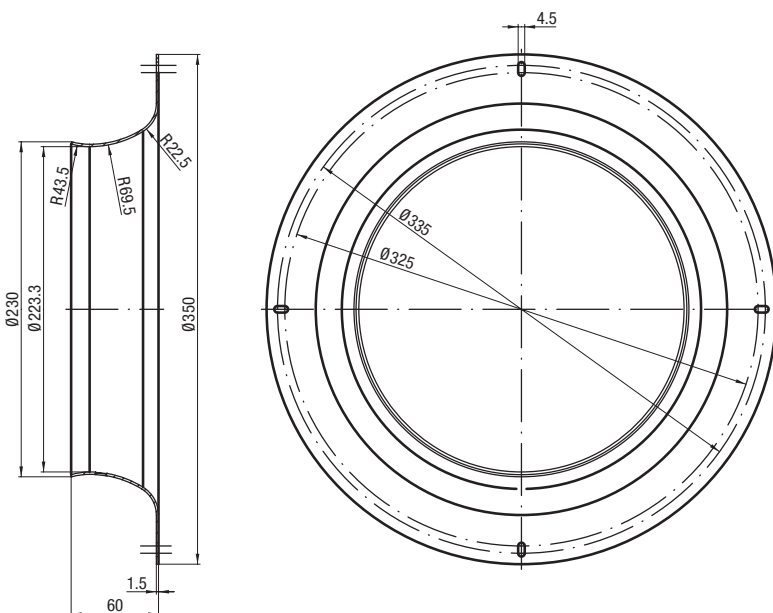

Fan size 400, Aluminium impeller
Part number
40070-2-4013

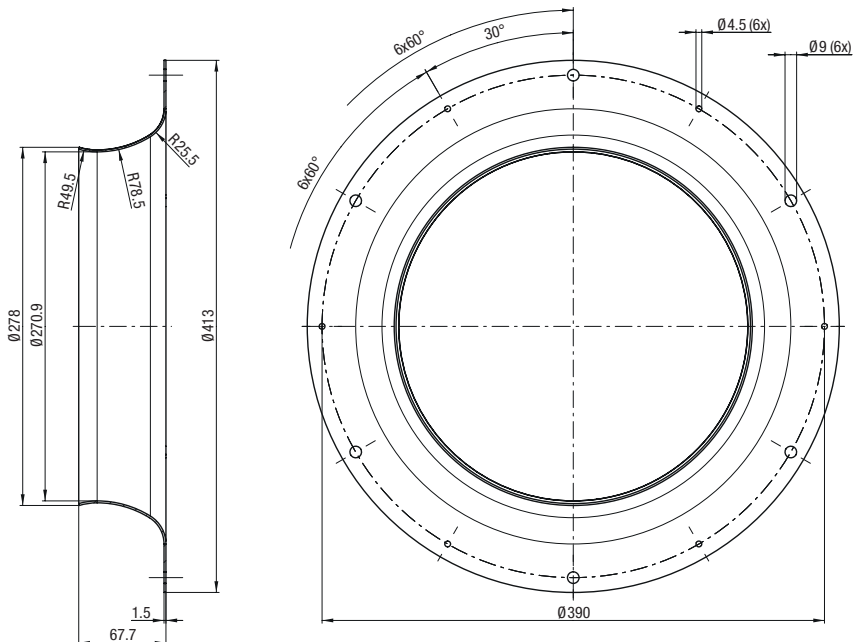

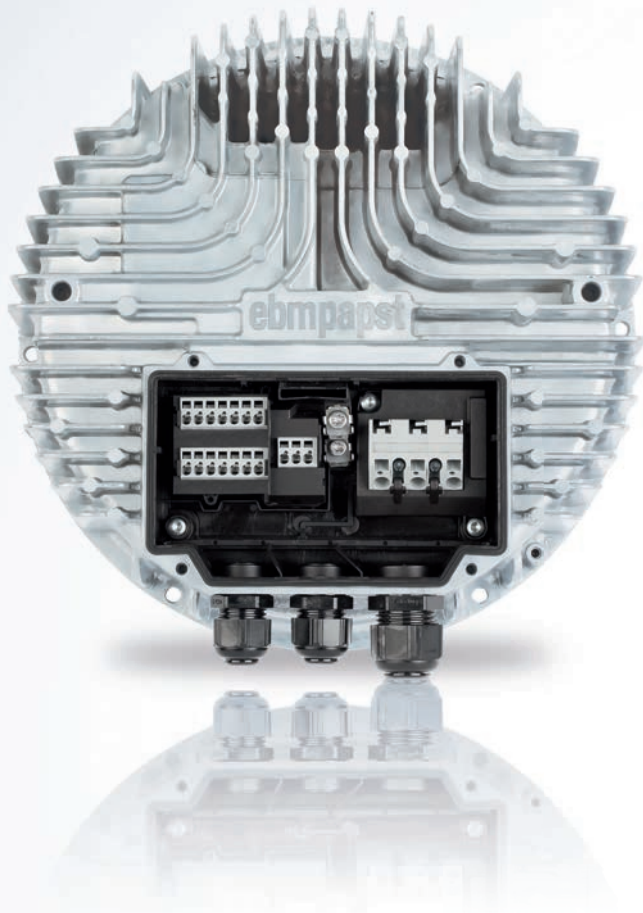

# Technology

## *rail technology*

**ebmpapst**

the engineer's choice

	Page
Connection diagrams	192
Technical parameters & scope	204

# Connection diagram: BA1)

## Technical features

- Control input 0-10 VDC / PWM
- Overvoltage detection
- Reverse polarity and locked-rotor protection
- Motor current limiter
- Tach output
- Soft start
- Over-temperature protected electronics

Wire 1



Wire	Designation	Colour	Assignment / function
1	UN +24 VDC	red	Power supply 24 VDC, residual ripple 3,5 %
	0-10 V / PWM	yellow	Control input: $R_i > 40 \text{ k}$ 0-10 V (Typ. $< 1 \text{ V} \rightarrow n=0$ ; $1,5 \text{ V} \rightarrow n=\text{min}$ ; $> 10 \text{ V} \rightarrow n=\text{max}$ ) PWM (Amplitude 10 V; 1-50 kHz; Typ. $< 5 \% \rightarrow n=0$ ; $15 \% \rightarrow n=\text{min}$ ; $100 \% \rightarrow n=\text{max}$ )
	DUE	white	Speed monitoring output, Open Collector, 3 pulses per revolution, Isink max = 10 mA
	GND	blue	Reference Ground

# Connection diagram: BA2)

## Technical features

- Control input 0-10 VDC / PWM
- Output limit
- Reverse polarity and locked-rotor protection
- Motor current limiter
- Temperature derating
- Soft start
- Over-temperature protected electronics
- Diagnostic output
- Load Dump (58 V)
- Overvoltage detection

Wire 1



Wire	Designation	Colour	Assignment / function
1	UN +24 VDC	black	Power supply, voltage range see nameplate
	GND	brown	Power supply, voltage range see nameplate
	DIAG	white	Diagnostic output: Open Collector, Isink max = 10 mA, Ri > 2,1 kΩ fan ok -> high; fan error -> low
	0-10 V / PWM	yellow	Control input: Ri > 47 kΩ 0-10 V (Typ. < 1 V -> n=0; 1,5 V -> n=min; > 10 V -> n=max) PWM (Amplitude 10 V; 1-50 kHz; Typ. < 5 % -> n=0; 15 % -> n=min; 100 % -> n=max)

# Connection diagram: BA3)

## Technical features

- Control input 0-10 VDC / PWM
- Lowering input
- INVLIN (Control input inverts linear)
- Fault output (Highside-Switch max. 10 mA)
- Temperature derating
- Output limit
- Reverse polarity and locked-rotor protection
- Soft start
- Over-temperature protected electronics
- Motor current limiter
- Overvoltage detection
- Load-Dump (58 V)

### Wire 1

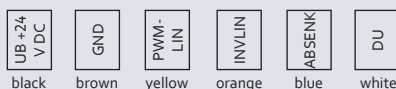

Wire	Designation	Colour	Assignment / function
1	UB +24 V DC	black	Power supply 24 V DC
	GND	brown	Power supply GND, reference ground
	0-10 V / PWM	yellow	Control input: $R_i > 47 \text{ k}\Omega$ 0-10 V (Typ. $< 1 \text{ V} \rightarrow n=0$ ; $1,5 \text{ V} \rightarrow n=\text{min}$ ; $> 10 \text{ V} \rightarrow n=\text{max}$ ) PWM (Amplitude 10 V; 1-50 kHz; Typ. $< 5 \% \rightarrow n=0$ ; $15 \% \rightarrow n=\text{min}$ ; $100 \% \rightarrow n=\text{max}$ )
	INVLIN	orange	Control input inverts linear ( $U_b = \text{Standby}$ , $21 \text{ V} = n \text{ min}$ , $0 \text{ V} = n \text{ max}$ )
	ABSENK	blue	Lowering input: when active ( $>4 \text{ V}$ ) value of the control input is halved
	DU	white	Diagnostic output, Highside-switch, $I_{\text{sink}_{\text{max}}} = 10 \text{ mA}$ , $R_i > 50 \Omega$ fan ok $\rightarrow$ low; fan error $\rightarrow$ high

# Connection diagram: BA4)

## Technical features

- Control input 0-10 VDC / PWM
- Fault output (Highside-Switch max. 10 mA)
- Temperature derating
- Output limit
- Reverse polarity and locked-rotor protection
- Soft start
- Over-temperature protected electronics
- Motor current limiter
- Overvoltage detection
- Load-Dump (58 V)

### Wire 1



Wire	Designation	Colour	Assignment / function
1	UN +24 VDC	black	Power supply 24 VDC
	DIAG	white	Diagnostic output, Highside-switch, $I_{\text{sink}_{\text{max}}} = 10 \text{ mA}$ , $R_i > 50 \Omega$ fan ok -> low; fan error -> high
	0-10 V / PWM	yellow	Control input: $R_i > 75 \text{ k}\Omega$ 0-10 V (Typ. $< 1 \text{ V} \rightarrow n=0$ ; $1,5 \text{ V} \rightarrow n=\text{min}$ ; $> 10 \text{ V} \rightarrow n=\text{max}$ ) PWM (Amplitude 10 V; 1-50 kHz; Typ. $< 5 \% \rightarrow n=0$ ; $15 \% \rightarrow n=\text{min}$ ; $100 \% \rightarrow n=\text{max}$ )
	GND	brown	Power supply GND, reference ground

# Connection diagram: BA5)

## Technical features

- Control input 0-10 VDC / PWM
- Output 10 VDC, max. 10 mA
- Alarm relay
- Integrated PID controller
- Output limit
- Run monitoring
- Reverse polarity and locked-rotor protection
- Soft start
- Motor current limiter
- Overvoltage / Undervoltage detection
- RS485 MODBUS-RTU
- Maximum EEPROM write cycles 100.000
- Control interface with SELV potential safely disconnected from the mains
- Over-temperature protected electronics

### Wire 1

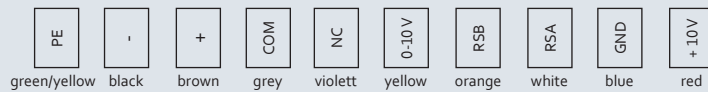

Wire	Designation	Colour	Assignment / function
1	PE	green/yellow	Protective earth
	-	black	Power supply GND, voltage range see name plate
	+	brown	Power supply, voltage range see name plate
	COM	grey	Status relay, floating status contact, common connection, contact rating 250 VAC / max. 2 A (AC1) / min. 1 mA / 5 V, reinforced insulation according to EN 50124-1 for switching voltages up to 110 VDC
	NC	violett	Status relay, floating status contact, break for failure,, contact rating 250 VAC / max. 2 A (AC1) / min. 1 mA / 5 V, reinforced insulation according to EN 50124-1 for switching voltages up to 110 VDC
	0-10 V / PWM	yellow	Control input: $R_i = 100 \text{ k}\Omega$ 0-10 V (Typ. < 1 V -> n=0; 1,5 V -> n=min; > 10 V -> n=max) PWM (Amplitude 10 V; 1-50 kHz; Typ. < 5 % -> n=0; 15 % -> n=min; 100 % -> n=max) parametrisable curve, SELV
	RSB	orange	RS485 interface for MODBUS, RSB, SELV
	RSA	white	RS485 interface for MODBUS, RSA, SELV
	GND	blue	Signal ground for control interface, SELV
	+10 V	red	Fixed voltage output 10 VDC, +10 V +/- 3 %, max. 10 mA, short-circuit-proof, power supply for external devices (e.g. potentiometer), SELV



# Connection diagram: BA6)

## Technical features

- Control input 0-10 VDC / PWM
- Output 10 VDC, max. 10 mA
- Alarm relay
- Integrated PID controller
- Output limit
- Run monitoring
- Reverse polarity and locked-rotor protection
- Soft start
- Motor current limiter
- Overvoltage / Undervoltage detection
- RS485 MODBUS-RTU
- Maximum EEPROM write cycles 100.000
- Control interface with SELV potential safely disconnected from the mains
- Over-temperature protected electronics / Motor



Wire	Designation	Colour	Assignment / function
1	PE	green/yellow	Protective earth
	-	black	Power supply GND, voltage range see name plate
	+	brown	Power supply, voltage range see name plate
2	COM	grey	Status relay, floating status contact, common connection, contact rating 250 VAC / max. 2 A (AC1) / min. 1 mA / 5 V, reinforced insulation according to EN 50124-1 for switching voltages up to 110 VDC
	NC	orange	Status relay, floating status contact, break for failure,, contact rating 250 VAC / max. 2 A (AC1) / min. 1 mA / 5 V, reinforced insulation according to EN 50124-1 for switching voltages up to 110 VDC
	0-10 V / PWM	yellow	Control input: $R_i = 100 \text{ k}\Omega$ 0-10 V (Typ. < 1 V -> n=0; 1,5 V -> n=min; > 10 V -> n=max) PWM (Amplitude 10 V; 1-50 kHz; Typ. < 5 % -> n=0; 15 % -> n=min; 100 % -> n=max) parametrisable curve, SELV
	RSB	brown	RS485 interface for MODBUS, RSB, SELV
	RSA	white	RS485 interface for MODBUS, RSA, SELV
	GND	blue	Signal ground for control interface, SELV
	+10 V	red	Fixed voltage output 10 VDC, +10 V +/- 3 %, max. 10 mA, short-circuit-proof, power supply for external devices (e.g. potentiometer), SELV

# Connection diagram: BA7)

## Technical features

- Control input 0-10 VDC / PWM
- Output 10 VDC, max. 10 mA
- Alarm relay
- Integrated PID controller
- Undervoltage/phase failure detection
- Output limit / Run monitoring
- PFC (passive) / Soft start
- Over-temperature protected electronics / Motor
- Motor current limiter
- Overvoltage detection
- RS485 MODBUS-RTU
- Maximum EEPROM write cycles 100.000
- Control interface with SELV potential safely disconnected from the mains
- Locked-rotor protection



Wire	Designation	Colour	Assignment / function
1	PE	green/yellow	Protective earth
	L1	black	Power supply, Phase, 50/60 Hz
	L2	blue	Power supply, Phase, 50/60 Hz
	L3	brown	Power supply, Phase, 50/60 Hz
2	COM	grey	Status relay, floating status contact, common connection, contact rating 250 VAC / max. 2 A (AC1), min. 1 mA / 5 VDC, reinforced insulation on control interface side, basic insulation on supply side according to EN 50124-1
	NC	orange	Statusrelais, floating status contact, break for failure,, contact rating 250 VAC / max. 2 A (AC1), min. 1 mA / 5 VDC, reinforced insulation on control interface side, basic insulation on supply side according to EN 50124-1
	0-10 V / PWM	yellow	Control input: Ri = 100 kΩ 0-10 V (Typ. < 1 V -> n=0; 1,5 V -> n=min; > 10 V -> n=max) PWM (Amplitude 10 V; 1-50 kHz; Typ. < 5 % -> n=0; 15 % -> n=min; 100 % -> n=max) parametrisable curve, SELV
	RSB	brown	RS485 interface for MODBUS, RSB, SELV
	RSA	white	RS485 interface for MODBUS, RSA, SELV
	GND	blue	Signal ground for control interface, SELV
	+10 V	red	Fixed voltage output 10 VDC, +10 V +/- 3 %, max. 10 mA, short-circuit-proof, power supply for external devices (e.g. potentiometer), SELV

# Connection diagram: BA8)

## Technical features

- Configurable inputs/outputs (I/O)
- RFID - ISO 15693 compatible
- Operation and alarm display with LED
- Integrated PID controller
- Reverse polarity and locked-rotor protection
- Motor current limiter / Alarm relay
- Soft start
- Undervoltage/phase failure detection
- Voltage output 3,3-24 VDC, Pmax = 800 mW
- RS 485 MODBUS-RTU / MODBUS V6
- Over-temperature protected electronics / Motor
- External 15-50 VDC input (parameterization)
- Control interface with SELV potential safely disconnected from supply

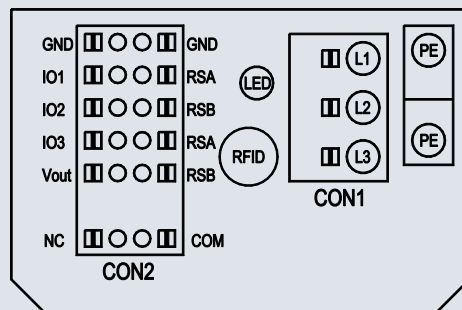

Terminal	Connection	Assignment / function
CON1	L1, L2, L3	Power supply, phase, voltage range see name plate, protection class 1
PE	PE	Protective earth
CON2	RSA	RS485 interface for MODBUS, RSA, SELV
	RSB	RS485 interface for MODBUS, RSB, SELV
	GND	Signal ground for control interface, SELV
	IO1	IN2: Digital input - positive logic (factory setting :Enable) funktion parameterizable, SELV - normal: Pin open or applied voltage < 1,5VDC - invers: applied voltage 3,5-50VDC
	IO2	IN1: Analog input 0-10V 0-10V, Ri=100K, parameterizable as set value or measured value (factory setting: set value) parametrisable curve, SELV
	IO3	OUT1: Analog output 0-10V 0-10V, max 5 mA, funktion parameterizable (factory setting: modulation level)) max output frequency 300 Hz, SELV
	V out	Voltage output 3,3-24 VDC +/-5 %, Pmax=800 mW, voltage parameterizable (factory setting: 10VDC) short-circuitproof, supply for external devices, SELV alternatively: 15-50VDC input for parameterization via Modbus without line voltage
	COM	Status relay, floating status contact, common connection, nominal voltage 250VAC; max 2A (AC1), min 10mA; reinforced insulation according to EN60335-1, EN61800-5-1, UL60730-1
	NC	Status relay, floating status contact, break for failure

# Connection diagram: BA9)

## Technical features

- external TOP, basic insulation

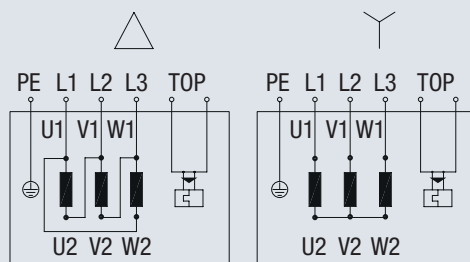

Note: Change of rotation direction by reversing two phases

Δ	Delta connection
Y	Star connection
L1	black
L2	blue
L3	brown
U1	black
V1	blue
W1	brown
U2	green
V2	white
W2	yellow
TOP	2 x grey, contact rating 250 V AC
PE	green/yellow

# Connection diagram: BA10)

## Technical features

- Reverse polarity protection
- Control input 0-10 VDC / PWM / external temperature control module / resistance
- Locked-rotor protection (electrical restart)
- Tacho signal

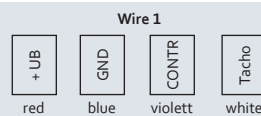

Wire	Designation	Colour	Assignment / function
1	+ UB	red	Power supply
	GND	blue	Reference ground
	CONTR	violett	Multioptions control input
	Tacho	white	Tacho signal

# Connection diagram: BA11)

## Technical features

- Reverse polarity protection
- Control input 0-5VDC / PWM
- Locked-rotor protection (electrical restart)

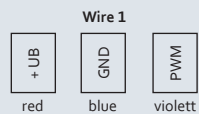

Wire	Designation	Colour	Assignment / function
1	+ UB	red	Power supply
	GND	blue	Reference ground
	PWM	violett	Control input



# Technical parameters & scope

## High standards for all ebm-papst products

Here at ebm-papst, we constantly strive to further improve our products in order to be able to offer you the best possible product for your application. Careful monitoring of the market ensures that technical innovations are reflected in the improvements of our products. Based on the technical parameters listed below and the ambience you want our product to operate in, we here at ebm-papst can always work out the best solution for your specific application.

### General performance parameters

Any deviations from the technical data and parameters described here are listed on the product-specific data sheet.

### Degree of protection

The type of protection is specified in the product-specific data sheets.

### Insulation class

The insulation class is specified in the product-specific data sheets.

### Installation position

The mounting position is specified in the product-specific data sheets.

### Condensate discharge holes

Information on the condensate discharge holes is provided in the product-specific data sheets.

### Mode of operation

The mode of operation is specified in the product-specific data sheets.

### Protection class

The protection class is specified in the product-specific data sheets.

### Service life

The service life of ebm-papst automotive products depends:

– The service life of the bearing system

The service life of the insulation system mainly depends on voltage level, temperature and ambient conditions, such as humidity and condensation.

The service life of the bearing system depends mainly on the thermal load on the bearing.

The majority of our products use maintenance-free ball bearings for any mounting position possible.

The service life L10 of the ball bearings can be taken as approx. 40,000 operating hours at an ambient temperature of 40 °C, yet this estimate can vary according to the actual ambient conditions.

We will gladly provide you with a lifetime calculation taking into account your specific operating conditions.

### Motor protection / thermal protection

Information on motor protection and thermal protection is provided in the product-specific data sheets.

Depending on motor type and field of application, the following protective features are realised:

- Thermal overload protector, connected
- PTC/NTC with electronic evaluation
- Current limiting using electronics

### Mechanical strain / performance parameters

All ebm-papst products are subjected to comprehensive tests complying with the normative specifications. In addition to this, the tests also reflect the vast experience and expertise of ebm-papst.

### High voltage and insulation testing

If high voltage or insulation testing is carried out in the application, then all connection lines from the fan must be disconnected in advance.



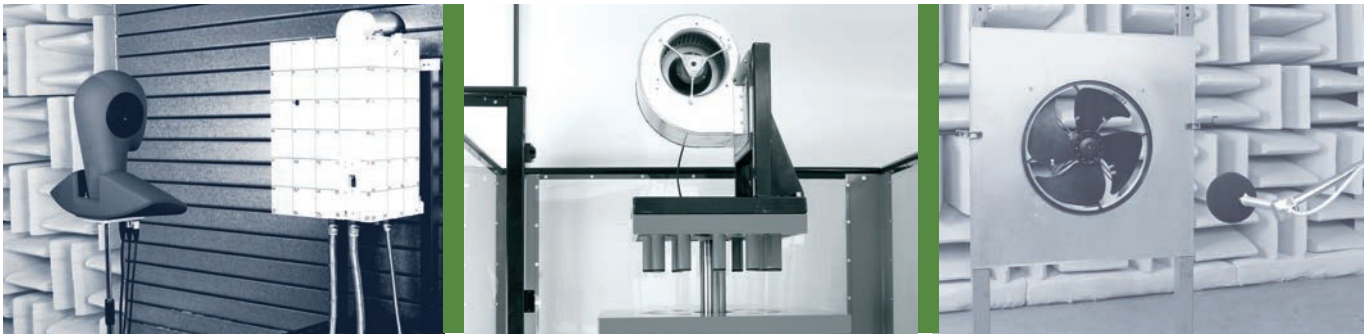

### Balancing quality

Testing the balancing quality is carried out in compliance with

- Residual imbalance according to DIN ISO 1940
- Standard balancing quality level G 6.3

Should you require a higher balancing quality level for your specific application, please let us know and specify this when ordering your product.

### Chemo-physical strain / performance parameters

Should you have questions about chemo-physical strain, please direct them to your ebm-papst contact.

### Fields of application, industries and applications

Our products are used in various industries and applications: The products in this catalogue have been specifically configured for use in the rail industry!

### Legal and normative directives

The products described in this catalogue are designed, developed and produced in keeping with the standards in place for the relevant product and, if known, the conditions governing the relevant fields of application.

### Standards

Information on standards is provided in the product-specific data sheets.

### EMC

Information on EMC standards is provided in the product-specific data sheets. Complying with the EMC standards has to be established on the final appliance, as different mounting situations can result in changed EMC properties.

### Approvals

In case you require a specific approval for your ebm-papst product (e1, UL, etc.) please let us know. Most of our products can be supplied with the relevant approval. Information on existing approvals is provided in the product-specific data sheets.

### Air performance measurements

All air performance measurements are carried out on suction side and on chamber test beds conforming to the specifications as per ISO 5801 and DIN 24163. The fans under test are installed in the measuring chamber at free air intake and exhaust (installation category A) and are operated at nominal voltage, with AC also at nominal frequency, and without any additional components such as guard grilles.

As required by the standard, the air performance curves correspond to an air density of 1.15 kg/m<sup>3</sup>.

# Technical parameters & scope

## Measurement conditions for air and noise measurement

ebm-papst products are measured under the following conditions:

- Axial and diagonal fans in direction of rotation "V" in full nozzle and without guard grill
- Backward curved centrifugal fans, free-running and with inlet nozzle
- Forward curved single and dual inlet centrifugal fans with housing

## Noise measurements

All noise measurements are carried out in low-reflective test rooms with reverberant floor. Thus the ebm-papst acoustic test chambers meet the requirements of precision class 1 according to DIN EN ISO 3745. For noise measurement, the fans being tested are placed in a reverberant wall and operated at nominal voltage (for AC, also at nominal frequency) without additional attachments such as the guard grill.

## Sound pressure level and sound level

All acoustic values are established according to ISO 13347, DIN 45635 and ISO 3744/3745 to accuracy class 2 and given in A-rated form.

When the sound pressure level ( $L_p$ ) is measured, the microphone is on the intake side of the fan being tested, usually at a distance of 1 m on the fan axis.

To measure the sound power level ( $L_w$ ) 10 microphones are distributed over an enveloping surface on the intake side of the fan being tested (see graphic). The sound power level measured can be roughly calculated from the sound pressure level by adding 7 dB.

### Measuring configuration as per ISO 13347-3 bzw. DIN 45635-38:

- 10 measuring points

$d \geq D$

$h = 1,5d \dots 4,5d$

Measurement area  $S = 6d^2 + 7d(h + 1,5d)$

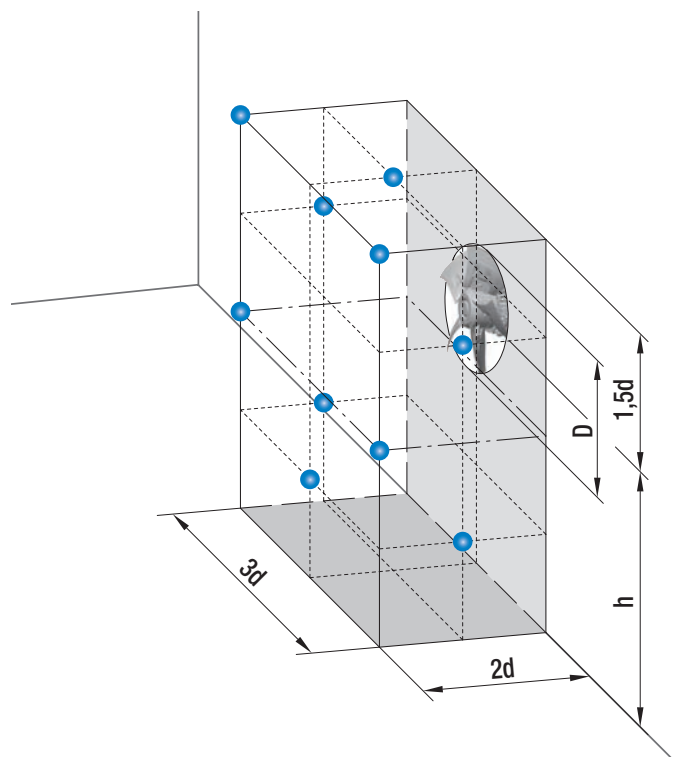

### Combined level of multiple same-level sound sources

Adding 2 noise sources with the same level results in a level increase of approx. 3 dB.

The noise characteristics of multiple identical fans can be determined in advance based on the noise values specified in the data sheet. This is shown in the diagram opposite.

**Example:** 8 A3G800 axial fans are on a condenser. According to the data sheet, the sound pressure level of a fan is approximately 75 dB(A). The level increase measured from the diagram is 9 dB. Thus the overall sound level of the installation can be expected to be 84 dB(A).

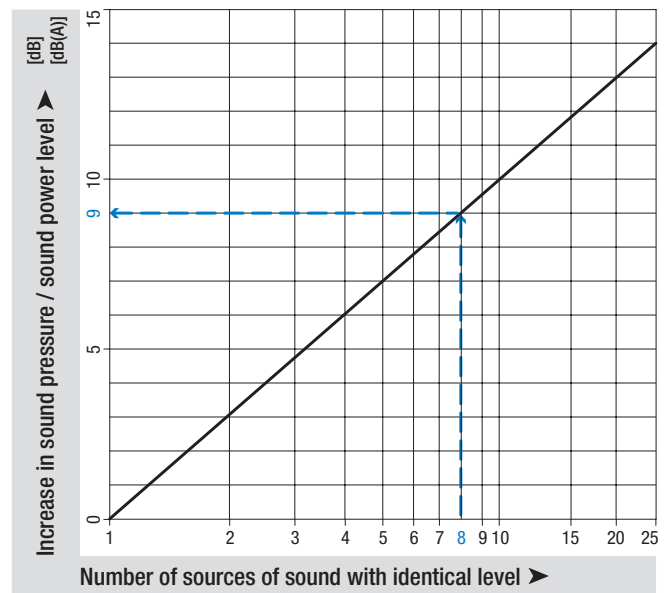

### Combined level of two different-level sound sources

The acoustic performance of two different fans can be predetermined based on the sound levels given in the data sheet. This is shown in the diagram opposite.

**Example:** There is an axial fan A3G800 with a sound pressure level of 75 dB(A) at the operating point and an axial fan A3G710 with 71 dB(A) in a ventilation unit. The level difference is 4 dB. The level increase can now be read in the diagram as approx. 1.5 dB. This means that the overall sound level of the unit can be expected to be 76.5 dB(A).

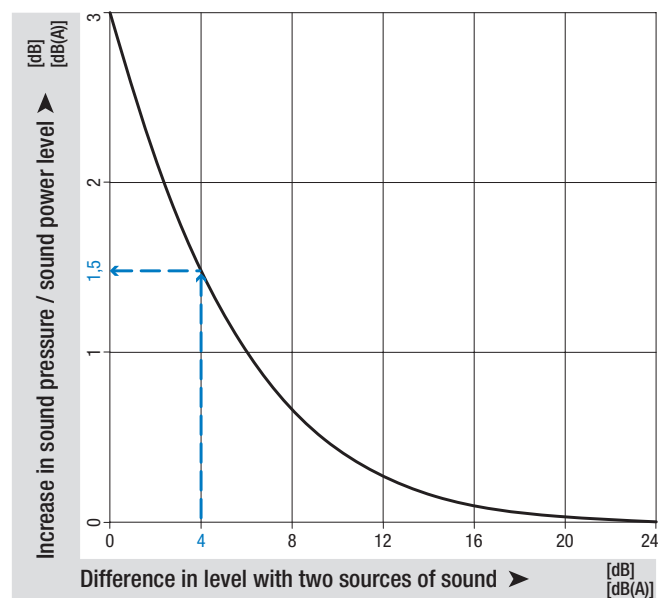

### Distance laws

Sound power level is independent of distance to the sound source. In contrast to this, sound pressure level decreases the further away the noise source is. The adjacent diagram shows the decrease in level under far sound field conditions. Far sound field conditions apply whenever the distance between microphone and fan is big when compared to fan diameter and wavelength to be considered. For more information on far sound field, please consult the relevant literature on this complex topic. Per doubling of distance, the level in the far sound field decreases by 6 dB. In the near field of the fan, other correlations apply and the decrease in levels can be considerably smaller. The following example only applies to far sound field conditions and can vary strongly depending on the installation effects: With an axial fan A3G300, a sound pressure level of 65 dB(A) was measured at a distance of 1 m. According to the adjacent diagram, at a distance of 20 m we would get a reduction by 26 dB, i.e. a sound pressure level of 39 dB(A).

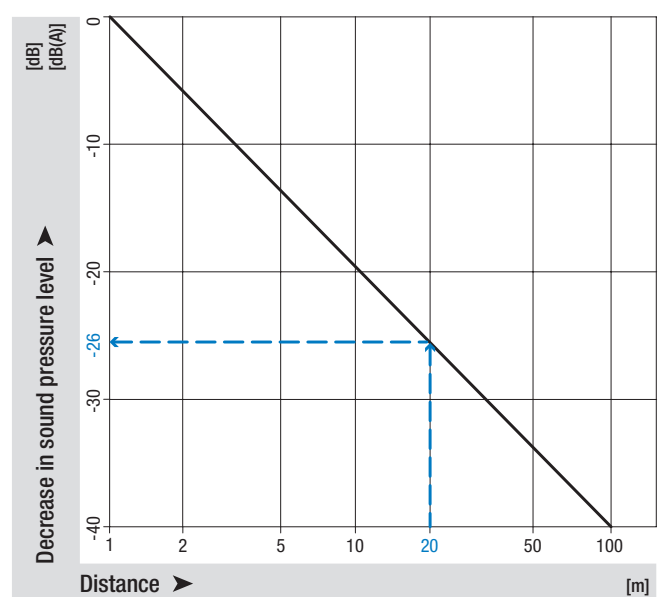

# Technical parameters & scope

## Aerodynamics fundamentals:

Further information can be found in our brochure "Technology - Basic principles"

### Axial fan operating range:

To the right of the saddle point (right section of the air performance curve):

- Maximum efficiency
- Minimum noise

To the left of the saddle point (left section of the air performance curve):

- Stall
- Irruptive efficiency
- Noise suddenly increases

The fan's optimal range of use is highlighted in green in the adjoining performance curve.

### Effects of guard grill:

Installing a guard grill reduces the axial fan's air performance.

The pressure loss in Pa can be roughly calculated using the following equation:

$$\Delta p_{SG} = \epsilon_{SG} \cdot 10^{-8} \cdot \dot{V}^2 \quad \dot{V} \text{ in } [m^3/h]$$

For the guard grill that ebm-papst used, the correction factor  $\epsilon_{SG}$  dependent on impeller diameter D can be found in the adjoining table.

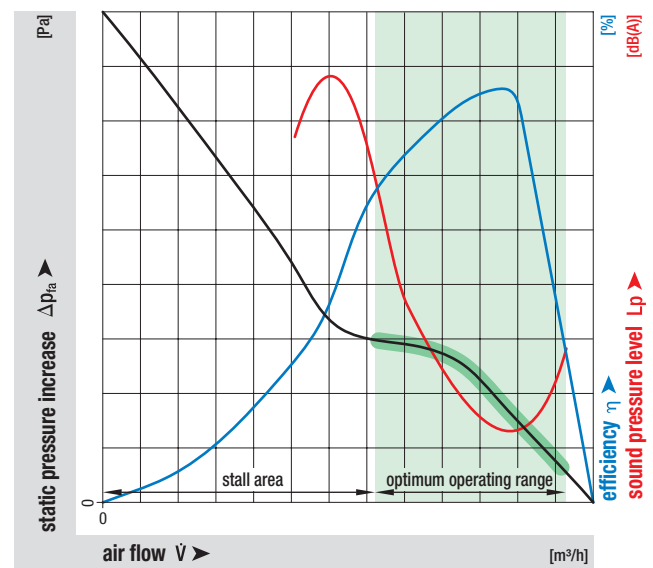

Diameter D	Correction factor $\epsilon_{SG}$
400	90
450	55
500	35

### Centrifugal fan operating range:

Middle section of the air performance curve:

- Maximum efficiency
- Minimum noise

To the left and right of the middle section of the air performance curve:

- Reduced efficiency
- Increasing noise

The fan's optimal range of use is highlighted in green in the adjoining performance curve.

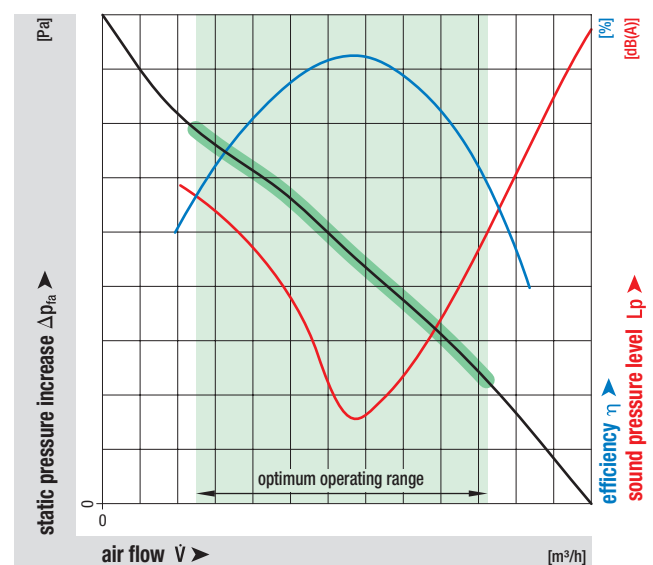

### Effects of installation space

Installation in a square box may cause a reduction of the air performance.

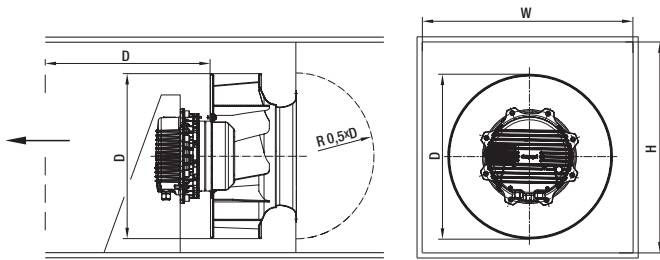

- $d_h$  = hydraulic diameter  
Formula:  $d_h = 2 \times W \times H / (W + H)$
- $W$  = Width of the box
- $H$  = Height of the box
- $D$  = Outside diameter of the fan

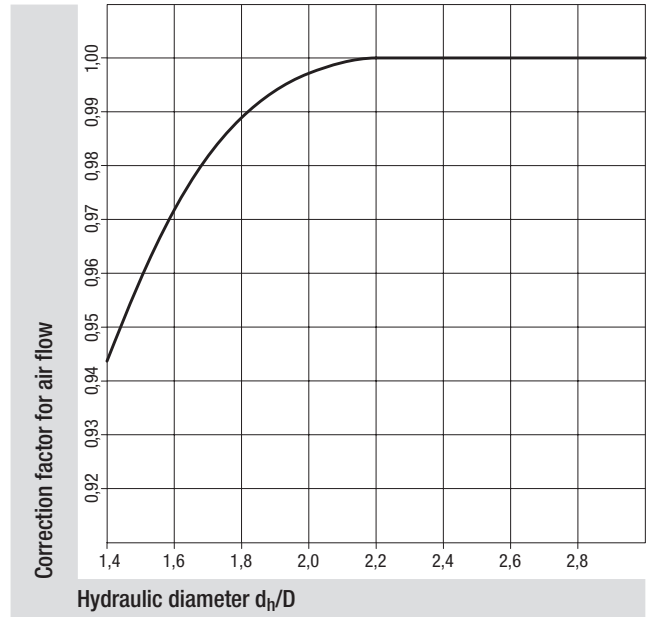

### Airflow determination for inlet rings with pressure tap:

The differential pressure method compares the static pressure upstream of the inlet ring with the static pressure in the inlet ring. The airflow can be calculated from the differential pressure (between the static pressures) according to the following equation:

$$q_v = k \cdot \sqrt{\Delta p} \quad q_v \text{ in [m}^3/\text{h]} \text{ and } \Delta p \text{ in [Pa]}$$

If the airflow is to be regulated to remain constant, the inlet pressure must be kept constant:

$$\Delta p = q_v^2 : k^2$$

$k$  takes the specific properties of the inlet ring into account.

The pressure is tapped at 1 (4) point(s) on the circumference of the inlet ring. The customer connection consists of a built-in T-shaped hose fitting. The hose fitting is suitable for pneumatic hoses with an inside diameter of 4 mm.

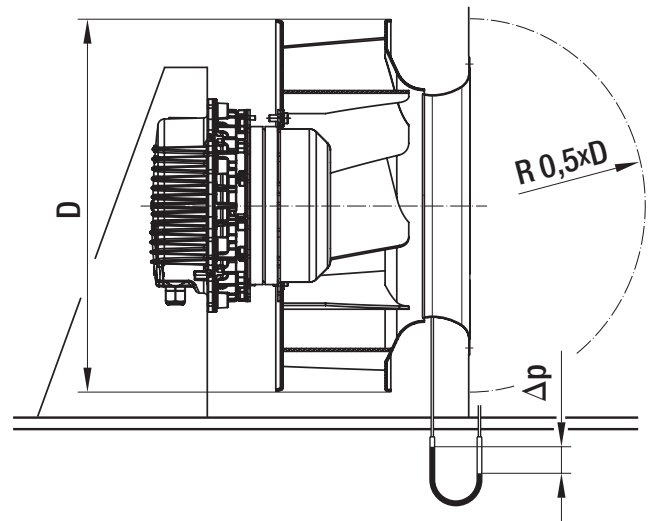

### Influence of speed $n$ on the sound power level $L_w$ :

The sound power level for changes in speed can be approximately determined based on the adjoining diagram and the following formula:

$$L_{w2} - L_{w1} = 50 \text{ dB} \cdot \log(n_2 : n_1)$$

- $L_{w1}$  = Sound power level after speed change
- $L_{w2}$  = Sound power level before speed change
- $n_1$  = Changed speed
- $n_2$  = Initial speed

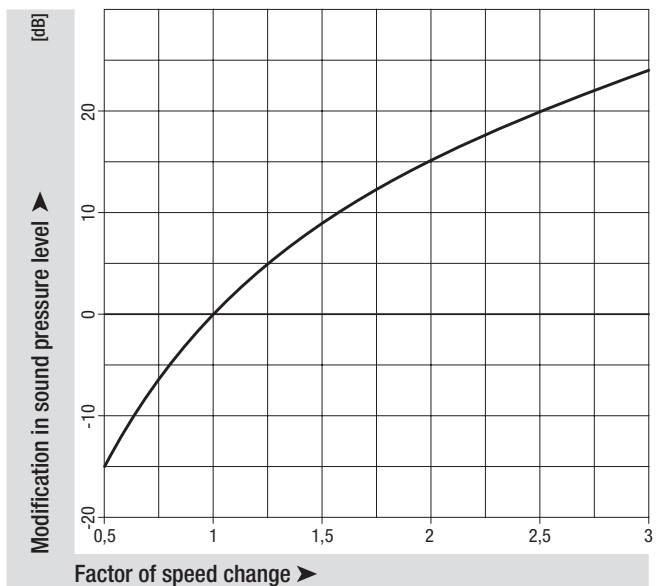

**ebm-papst Mulfingen GmbH & Co. KG**

Bachmühle 2  
74673 Mulfingen  
GERMANY  
Phone +49 7938 81-0  
Fax +49 7938 81-110  
info1@de.ebmpapst.com

**ebm-papst St. Georgen GmbH & Co. KG**

Hermann-Papst-Straße 1  
78112 St. Georgen  
GERMANY  
Phone +49 7724 81-0  
Fax +49 7724 81-1309  
info2@de.ebmpapst.com

**ebm-papst Landshut GmbH**

Hofmark-Aich-Straße 25  
84030 Landshut  
GERMANY  
Phone +49 871 707-0  
Fax +49 871 707-465  
info3@de.ebmpapst.com



# Agents

## *Worldwide*

**ebmpapst**

the engineer's choice

	Page
ebm-papst in Germany	212
ebm-papst in Europe	213
ebm-papst in America and Africa	215
ebm-papst in Asia	216
ebm-papst in Oceania	217



# ebm-papst in Germany



**Berlin**  
Dipl.-Ing. (TH) Jens Duchow  
Händelstraße 7  
16341 Panketal  
GERMANY  
Phone +49 30 944149-62  
Fax +49 30 944149-63  
Jens.Duchow@de.ebmpapst.com



**Bielefeld**  
Dipl.-Ing. (FH) Wolf-Jürgen Weber  
Niehausweg 13  
33739 Bielefeld  
GERMANY  
Phone +49 5206 91732-31  
Fax +49 5206 91732-35  
Wolf-Juergen.Weber@de.ebmpapst.com



**Dortmund**  
Dipl.-Ing. (FH) Hans-Joachim Pundt  
Auf den Steinern 3  
59519 Möhnesee-Völlinghausen  
GERMANY  
Phone +49 2925 800-407  
Fax +49 2925 800-408  
Hans-Joachim.Pundt@de.ebmpapst.com



**F anktfurt**  
Dipl.-Ing. Christian Kleffmann  
Dr.-Hermann-Krause-Straße 23  
63452 Hanau  
GERMANY  
Phone +49 6181 1898-12  
Fax +49 6181 1898-13  
Christian.Kleffmann@de.ebmpapst.com



**Halle**  
Dipl.-Ing. (TU) Michael Hanning  
Lercheneck 4  
06198 Salzatal / OT Lieskau  
GERMANY  
Phone +49 345 55124-56  
Fax +49 345 55124-57  
Michael.Hanning@de.ebmpapst.com



**Hamburg**  
Ingenieurbüro Breuell GmbH  
Ing. Dirk Kahl  
Elektroingenieur  
Oststraße 96  
22844 Norderstedt  
GERMANY  
Phone +49 40 538092-19  
Fax +49 40 538092-84  
Kahl@breuell-hilgenfeldt.de



**Heilbronn / Heidelberg**  
Wolfgang Richter  
Büttelsbergweg 18  
97980 Bad Mergentheim-Rengershausen  
GERMANY  
Phone +49 7937 32200-33  
Fax +49 7938 81-110  
Wolfgang.Richter@de.ebmpapst.com



**Kassel**  
Dipl.-Ing. (FH) Ralph Brück  
Hoherainstraße 3 b  
35075 Gladenbach  
GERMANY  
Phone +49 6462 4071-10  
Fax +49 6462 4071-11  
Ralph.Brueck@de.ebmpapst.com



**Koblenz**  
Winfried Schaefer  
Hinter der Kirch 10  
56767 Uersfeld  
GERMANY  
Phone +49 2657 16-96  
Fax +49 2657 16-76  
Winfried.Schaefer@de.ebmpapst.com



**Munich**  
Dipl.-Wirt.-Ing. (FH) Jens Peter  
Landsbergerstraße 14  
86932 Pürgen  
GERMANY  
Phone +49 8196 99877-54  
Fax +49 8196 99877-55  
Jens.Peter@de.ebmpapst.com



**Nuremberg**  
Dipl.-Wirt.-Ing. (FH) Axel Resch  
Dr.-August-Koch-Str. 1  
91639 Wolframs-Eschenbach  
GERMANY  
Phone +49 9875 9783-170  
Fax +49 9875 9783-171  
Axel.Resch@de.ebmpapst.com



**Offenburg**  
Dipl.-Ing. (FH) Ralf Braun  
Hubeneck 21  
77704 Oberkirch  
GERMANY  
Phone +49 7802 9822-52  
Fax +49 7802 9822-53  
Ralf.Braun@de.ebmpapst.com



**Stuttgart**  
Dipl.-Ing. (FH) Rudi Weinmann  
Hindenburgstraße 100/1  
73207 Plochingen  
GERMANY  
Phone +49 7153 9289-80  
Fax +49 7153 9289-81  
Rudi.Weinmann@de.ebmpapst.com



**Ulm**  
M.Sc. Reinhard Sommerreißer  
Einsteinstraße 7a  
86674 Baar / Schwaben  
GERMANY  
Phone +49 8276 5899-775  
Fax +49 7938 81-110  
Reinhard.Sommerreisser@de.ebmpapst.com

## Distributors



**F anktfurt**  
R.E.D. Handlungsgesellschaft mbH  
Gutenbergstraße 3  
63110 Rodgau - Jügesheim  
GERMANY  
Phone +49 6106 841-0  
Fax +49 6106 841-111  
info@red-elektromechnik.de  
www.red-elektromechnik.de



**Hamburg**  
Breuell + Hilgenfeldt GmbH  
Oststraße 96  
22844 Norderstedt  
GERMANY  
Phone +49 40 538092-20  
Fax +49 40 538092-84  
info@breuell-hilgenfeldt.de



**Munich**  
A. Schweiger GmbH  
Ohmstraße 1  
82054 Sauerlach  
GERMANY  
Phone +49 8104 897-0  
Fax +49 8104 897-90  
info@schweiger-gmbh.de  
www.schweiger-gmbh.com

● **Express Service-Center** (1 to 5 pieces)



**North**  
Breuell + Hilgenfeldt GmbH  
Oststraße 96  
22844 Norderstedt  
GERMANY  
Phone +49 40 538092-20  
Fax +49 40 538092-84  
info@breuell-hilgenfeldt.de



**South**  
HDS Ventilatoren Vertriebs GmbH  
Glaswiesenstraße 1  
74677 Dörzbach  
GERMANY  
Phone +49 7937 80355-20  
Fax +49 7937 80355-25  
info@hds-gmbh.net  
www.hds-gmbh.net

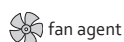

fan agent

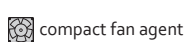

compact fan agent

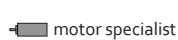

motor specialist

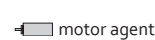

motor agent





# ebm-papst in Europe

## Europe

 **Austria**  
 ebm-papst Motoren & Ventilatoren GmbH  
 Straubingstraße 17  
4030 Linz  
AUSTRIA  
Phone +43 732 321150-0  
Fax +43 732 321150-20  
info@at.ebmpapst.com  
www.ebmpapst.at

 **Belarus**  
 ebm-papst Bel AgmbH  
 4<sup>th</sup> Montazhnikov side street  
House 6, Office 332  
BY-220019 Minsk  
BELARUS  
Phone +375 17 2015216  
Fax +375 17 2015216  
info@by.ebmpapst.com  
www.ebmpapst.by

 **Belgium**  
 ebm-papst Benelux B.V.  
 Sales office Belgium-Luxemburg  
Romeinsestraat 6/0101  
Research Park Haasrode  
3001 Heverlee-Leuven  
BELGIUM  
Phone +32 16 396-200  
Fax +32 16 396-220  
info@be.ebmpapst.com  
www.ebmpapst.be

 **Bulgaria**  
 ebm-papst Romania S.R.L.  
 Str. Tarnavei No. 20  
500327 Brasov  
ROMANIA  
Phone +40 268 331859  
Fax +40 268 312805  
dudasludovic@xnet.ro

 **Croatia**  
 ebm-papst Industries Kft.  
 Ezred u. 2.  
1044 Budapest  
HUNGARY  
Phone +36 1 8722-190  
Fax +36 1 8722-194  
office@hu.ebmpapst.com

 **Cyprus**  
 Helcoma  
 E. Rota and Co. OE  
Davaki 65  
17672 Kallithea-Attiki  
GREECE  
Phone +30 210 9513-705  
Fax +30 210 9513-490  
contact@helcoma.gr  
www.helcoma.gr



 **Czech Republic / Slovakia**  
 ebm-papst CZ s.r.o.  
 Kaštanová 34a  
620 00 Brno  
CZECH REPUBLIC  
Phone +420 544 502-411  
Fax +420 547 232-622  
info@ebmpapst.cz  
www.ebmpapst.cz

 **Denmark**  
 ebm-papst Denmark ApS  
 Vallensbækvej 21  
2605 Brøndby  
DENMARK  
Phone +45 43 631111  
Fax +45 43 630505  
mail@dk.ebmpapst.com  
www.ebmpapst.dk

 **Estonia**  
 ebm-papst Oy, Eesti Filiaal  
 Keskk tee 21  
Aaviku küla, Jüri Tehnopaik  
75301 Rae Vald, Harjumaa  
ESTONIA  
Phone +372 65569-78  
www.ebmpapst.ee



 **Finland**  
 ebm-papst Oy  
 Puistotie 1  
02760 Espoo  
FINLAND  
Phone +358 9 887022-0  
Fax +358 9 887022-13  
mailbox@ebmpapst.fi  
www.ebmpapst.fi

 **France**  
 ebm-papst sarl  
 Parc d'Activités Nord  
1 rue Mohler – BP 62  
67212 Obernai Cedex  
FRANCE  
Phone +33 3 88 66 88 03  
info@ebmpapst.fr  
www.ebmpapst.fr

 **Greece**  
 HELCOMA  
 HELLAS IKE  
65, Davaki street  
17672 Kallithea-Attiki  
GREECE  
Phone +30 210 9513-705  
Fax +30 210 9513-490  
contact@helcoma.gr  
www.helcoma.gr

 **Hungary**  
 ebm-papst Industries Kft.  
 Ezred u. 2.  
1044 Budapest  
HUNGARY  
Phone +36 1 8722-190  
Fax +36 1 8722-194  
office@hu.ebmpapst.com

 **Iceland**  
 RJ Engineers  
 Stangarhyl 1a  
110 Reykjavik  
ICELAND  
Phone +354 567 8030  
Fax +354 567 8015  
rj@rj.is  
www.rj.is

 **Ireland**  
 ebm-papst UK Ltd.  
 Chelmsford Business Park  
Chelmsford Essex CM2 5EZ  
UNITED KINGDOM  
Phone +44 1245 468555  
Fax +44 1245 466336  
sales@uk.ebmpapst.com  
www.ebmpapst.co.uk

 **AuBren Limited**  
 Portlaoise Business & Technology Park  
 Mountrath Road  
Portlaoise, Co. Laois  
IRELAND  
Phone +353 57 8664343  
Fax +353 57 8664346  
sales@ie.aubren.com  
www.aubren.com

 **Italy**  
 ebm-papst Srl  
 Via Cornaggia 108  
22076 Mozzate (Co)  
ITALY  
Phone +39 0331 836201  
Fax +39 0331 821510  
info@it.ebmpapst.com  
www.ebmpapst.it

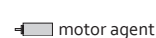
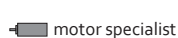
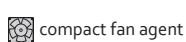
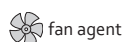

# ebm-papst in Europe



**Macedonia**  
ebm-papst Industries Kft.  
Ezred u. 2.  
1044 Budapest  
HUNGARY  
Phone +36 1 8722-190  
Fax +36 1 8722-194  
office@hu.ebmpapst.com



**Netherlands**  
ebm-papst Benelux B.V.  
Polbeemd 7 - 5741 TP Beek en Donk  
P.O. Box 140 - 5740 AC Beek en Donk  
NETHERLANDS  
Phone +31 492 502-900  
Fax +31 492 502-950  
verkoop@nl.ebmpapst.com  
www.ebmpapst.nl

ebm-papst Heating Systems B.V.  
Van Veldekekade 360  
5216 KT 's-Hertogenbosch  
NETHERLANDS  
Phone +31 73 648 89 00  
Fax +31 73 648 89 11  
info@ebmpapst-hs.nl  
www.ebmpapst-hs.nl



**Norway**  
ebm-papst AS  
P.B. 173 Holmlia  
1203 Oslo  
NORWAY  
Phone +47 22 763340  
Fax +47 22 619173  
mailbox@ebmpapst.no  
www.ebmpapst.no



**Poland**  
ebm-papst Polska Sp. z o.o.  
ul. Annopol 4A  
03236 Warszawa  
POLAND  
Phone +48 22 6757819  
Fax +48 22 6769587  
office@ebmpapst.pl  
www.ebmpapst.pl



**Portugal**  
ebm-papst (Portugal), Lda.  
Centro Empresarial de Alverca  
Rua de Adarse, Vale D'Ervas  
Corpo D / Fracção 3  
2615-178 Alverca do Ribatejo  
PORTUGAL  
Phone +351 218 394 880  
Fax +351 218 394 759  
info@pt.ebmpapst.com  
www.ebmpapst.pt



**Romania**  
ebm-papst Romania S.R.L.  
Str. Tarnavei Nr. 20  
500327 Brasov  
ROMANIA  
Phone +40 268 331859  
Fax +40 268 312805  
dudasludovic@xnet.ro



**Russia**  
ebm-papst Rus GmbH  
Olimpiyskiy prospect 29A, office 418  
141006 Mytistschi, Oblast Moskau  
RUSSIA  
Phone +7 495 9807524  
Fax +7 495 5140924  
info@ebmpapst.ru  
www.ebmpapst.ru



ebm-papst Ural GmbH  
Posadskaja-Strasse, 23(E), 3  
620102 Ekaterinburg  
RUSSIA  
Phone +7 343 2338000  
Fax +7 343 2337788  
Konstantin.Molokov@ru.ebmpapst.com  
www.ebmpapst.ru



**Serbia & Montenegro**  
ebm-papst Industries Kft.  
Ezred u. 2.  
1044 Budapest  
HUNGARY  
Phone +36 1 8722-190  
Fax +36 1 8722-194  
office@hu.ebmpapst.com



**Spain**  
ebm-papst Ibérica S.L.  
Avda. del Sistema Solar, 29  
28830 San Fernando de Henares (Madrid)  
SPAIN  
Phone +34 91 6780894  
Fax +34 91 6781530  
ventas@ebmpapst.es  
www.ebmpapst.es



**Sweden**  
ebm-papst AB  
Äggelundavägen 2  
17562 Järfälla  
SWEDEN  
Phone +46 10 4544400  
Fax +46 8 362306  
info@ebmpapst.se  
www.ebmpapst.se



**Switzerland**  
ebm-papst AG  
Rütisbergstrasse 1  
8156 Oberhasli  
SWITZERLAND  
Phone +41 44 73220-70  
Fax +41 44 73220-77  
verkauf@ebmpapst.ch  
www.ebmpapst.ch



**Turkey**  
Akantel Elektronik San. Tic. LTD. Sti.  
Atatürk Organize Sanayi  
Bölgesi 10007 SK. No.:6  
35620 Cigli-Izmir  
TURKEY  
Phone +90 232 3282090  
Fax +90 232 3280270  
akantel@akantel.com.tr  
www.ebmpapst.com.tr



**Ukraine**  
ebm-papst Ukraine LLC  
Lepse Boulevard, 4, Building 21  
03067 Kiev  
UKRAINE  
Phone +38 044 2063091  
Fax +38 044 2063091  
mail@ebmpapst.ua  
www.ebmpapst.ua



**United Kingdom**  
ebm-papst UK Ltd.  
Chelmsford Business Park  
Chelmsford Essex CM2 5EZ  
UNITED KINGDOM  
Phone +44 1245 468555  
Fax +44 1245 466336  
sales@uk.ebmpapst.com  
www.ebmpapst.co.uk



ebm-papst Automotive & Drives (UK) Ltd.  
The Smithy  
Fidlers Lane  
East Ilsley, Berkshire RG20 7LG  
UNITED KINGDOM  
Phone +44 1635 2811-11  
Fax +44 1635 2811-61  
A&Dsales@uk.ebmpapst.com  
www.ebmpapst-ad.com

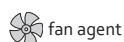

# ebm-papst in America & Africa

## America

 **Argentina**  
ebm-papst Argentina S.A.  
Parque Industrial Canning Etapa II - Nave  
61A, Perito Moreno 845, Canning (1804),  
Buenos Aires  
ARGENTINA  
Phone +54 11 46576135  
Fax +54 11 46572092  
ventas@ar.ebmpapst.com  
www.ebmpapst.com.ar

 **Brazil**  
ebm-papst Motores Ventiladores Ltda.  
Av. José Giorgi, 301 Galpões B6+B7  
Condominio Logical Center  
06707-100 Cotia - São Paulo  
BRAZIL  
Phone +55 11 4613-8700  
Fax +55 11 4777-1456  
vendas@br.ebmpapst.com  
www.ebmpapst.com.br

 **Canada**  
ebm-papst Canada Inc.  
1800 Ironstone Manor, Unit 2  
Pickering, Ontario, L1W3J9  
CANADA  
Phone +1 905 420-3533  
Fax +1 905 420-3772  
sales@ca.ebmpapst.com  
www.ebmpapst.ca

 **Mexico**  
ebm Industrial S. de R.L. de C.V.  
Paseo de Tamarindos 400-A-5to Piso  
Col. Bosques de las Lomas  
Mexico 05120, D.F.  
MEXICO  
Phone +52 55 3300-5144  
Fax +52 55 3300-5243  
sales@mx.ebmpapst.com  
www.ebmpapst.com.mx

## USA

 ebm-papst Inc.  
P.O. Box 4009  
100 Hyde Road  
Farmington, CT 06034  
UNITED STATES  
Phone +1 860 674-1515  
Fax +1 860 674-8536  
sales@us.ebmpapst.com  
www.ebmpapst.us

 ebm-papst Inc.  
Automotive & Drives Business Unit  
3200 Greenfield Road, Suite 130  
Dearborn, MI 48120  
UNITED STATES  
Phone +1 313 406-8080  
Fax +1 313 406-8081  
automotive@us.ebmpapst.com  
www.ebmpapst-automotive.us

## Africa

 **South Africa**  
ebm-papst South Africa (Pty) Ltd.  
P.O. Box 3124  
1119 Yacht Avenue  
2040 Honeydew  
SOUTH AFRICA  
Phone +27 11 794-3434  
Fax +27 11 794-5020  
info@za.ebmpapst.com  
www.ebmpapst.co.za

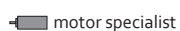
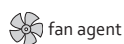

# ebm-papst in Asia

## Asia

 **China**  
ebm-papst Ventilator (Shanghai) Co., Ltd.  
 No. 418, Huajing Road  
 WaiGaoQiao Free Trade Zone  
No. 2001, Yang Gao (N) Road  
200131 Shanghai  
P.R. of CHINA  
Phone +86 21 5046-0183  
Fax +86 21 5046-1119  
sales@cn.ebmpapst.com  
www.ebmpapst.com.cn

 **Hong Kong**  
ebm-papst Hong Kong Ltd.  
 Room 17E, MG Tower  
 133 Hoi Bun Road, Kwun Tong  
Hong Kong  
P.R. of CHINA  
Phone +852 2145-8678  
Fax +852 2145-7678  
info@hk.ebmpapst.com

 **India**  
ebm-papst India Pvt. Ltd.  
 26/3, G.N.T. Road, Erukkencherry  
 Chennai-600118  
INDIA  
Phone +91 44 25372556  
Fax +91 44 25371149  
sales@in.ebmpapst.com  
www.ebmpapst.in

 **Indonesia**  
ebm-papst Indonesia  
 Representative Office  
 German Centre, 4th Floor, Suite 4470  
Jl. Kapt. Subijono Dj. Bumi Serpong Damai  
15321 Tangerang  
INDONESIA  
Phone +62 21 5376250  
Fax +62 21 5388305  
salesdept@id.ebmpapst.com



 **Israel**  
Polak Bros. Import Agencies Ltd.  
 9 Hamefalsim Street  
 Kiryat Arie, Petach-Tikva 49514  
ISRAEL  
Phone +972 3 9100300  
Fax +972 3 5796679  
polak@polak.co.il  
www.polak.co.il

 **Japan**  
ebm-papst Japan K.K.  
 Attend on Tower 13F  
 Shinyokohama 2-8-12, Kohoku-ku  
222-0033 Yokohama-City, Kanagawa  
JAPAN  
Phone +81 45 47057-51  
Fax +81 45 47057-52  
info@jp.ebmpapst.com  
www.ebmpapst.jp



 **Korea**  
ebm-papst Korea Co. Ltd.  
 6F, Trutec Bldg.  
 12, WorldCupbuk-ro 56-gil  
Mapo-Gu  
Seoul 03924  
KOREA  
Phone +82 2 366213-24  
Fax +82 2 366213-26  
info@kr.ebmpapst.com  
www.ebmpapst.co.kr

 **Malaysia**  
ebm-papst Malaysia  
 Representative Office  
 No. 16-1, Jalan Putra Mahkota 7/5A  
Putra Heights  
Selangor Darul Ehsan  
47650 Subang Jaya  
MALAYSIA  
Phone +60 3 5192-7688  
Fax +60 3 5614-3078  
salesdept@my.ebmpapst.com

 **Philippines**  
ebm-papst SEA Pte. Ltd.  
 Representative Office (Philippines)  
 ALPAP II Building  
Trade Street Corner Investment Drive  
Unit 1101 Madrigal Business Park  
1799 Ayala Alabang / Muntinlupa City  
Telefon: +63 02 8042747  
Telefax: +63 02 8042757  
salesdept@ph.ebmpapst.com

 **Singapore**  
ebm-papst SEA Pte. Ltd.  
 9 Tai Seng Drive  
 #03-01 Geo-Tele Centre, Lobby B  
Singapore 535227  
SINGAPORE  
Phone +65 65513789  
Fax +65 68428439  
salesdept@sg.ebmpapst.com

 **Taiwan**  
ETECO Engineering & Trading Corp.  
 10F-I, No. 92, Teh-Wei Str.  
 Tsow-Inn District, Kaohsiung  
TAIWAN  
Phone +886 7 557-4268  
Fax +886 7 557-2788  
eteco@ms22.hinet.net  
www.ebmpapst.com.tw

 **Thailand**  
ebm-papst Thailand Co., Ltd.  
 99/9 Moo 2, Central Chaengwattana Tower  
 14th Floor, Room 1402  
Chaengwattana Road Bangtarad, Pakkret  
11120 Nonthaburi  
THAILAND  
Phone +66 2 8353785-7  
Fax +66 2 8353788  
salesdept@th.ebmpapst.com

 **United Arab Emirates**  
ebm-papst Middle East FZE  
 PO Box 17755  
 Jebel Ali Free Zone / FZS1 / AP05  
Dubai  
UNITED ARAB EMIRATES  
Phone +971 4 88608-26  
Fax +971 4 88608-27  
info@ae.ebmpapst.com  
www.ebmpapst.ae

 **Vietnam**  
ebm-papst SEA Pte. Ltd.  
 Representative Office (Vietnam)  
 Floor M, Phuong Long Building,  
506 Nguyen Dinh Chieu Street,  
Ward 4, District 3,  
Ho Chi Minh City, Vietnam  
VIETNAM  
Phone +84 28 3929 0699 / 3929 0670  
Fax +84 28 3929 0669  
salesdept@vn.ebmpapst.com

# ebm-papst in Oceania

## Oceania

---



### Australia

ebm-papst A&NZ Pty Ltd.  
10 Oxford Road  
Laverton North, Victoria, 3026  
AUSTRALIA  
Phone +61 3 9360-6400  
Fax +61 3 9360-6464  
sales@ebmpapst.com.au  
www.ebmpapst.com.au



### New Zealand

ebm-papst A&NZ Pty Ltd.  
61 Hugo Johnston Drive, Unit H  
Penrose 1061, Auckland  
NEW ZEALAND  
PO Box 112278,  
Penrose 1642, Auckland  
Phone +64 9 525-0245  
Fax +64 9 525-0246  
sales@ebmpapst.com.au  
www.ebmpapst.com.au

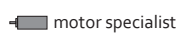
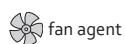

# Notes

# Notes

# ebmpapst

the engineer's choice



**ebm-papst**  
**Mulfingen GmbH & Co. KG**

Bachmühle 2  
74673 Mulfingen  
Germany  
Phone +49 7938 81-0  
Fax +49 7938 81-110  
info1@de.ebmpapst.com

**ebm-papst**  
**St. Georgen GmbH & Co. KG**

Hermann-Papst-Straße 1  
78112 St. Georgen  
Germany  
Phone +49 7724 81-0  
Fax +49 7724 81-1309  
info2@de.ebmpapst.com